

GT405



KONGSBERG



PRESSURE TRANSMITTER

The KONGSBERG GT405 is a type approved pressure transmitter specially designed for maritime applications. The transmitter combines maximum precision with easy operation for use in processes where pressure and level measurement with high accuracy and stability is required over a long period of time. The integrated display can show measured pressure, output current or ambient temperature of sensor electronics.

Principle of operation

The pressure sensing element is a silicon sensor with stainless steel separating diaphragm, dedicated for applications where high reliability and durability is required to withstand pressure shocks, vibration and varying temperatures. The sensor can be used for the majority of fluids and gases as the high-quality stainless steel process connection is resistant to most chemicals and offers outstanding accuracy of $\leq 0,1\%$ of full range output. An all welded mechanical assembly provides a high integrity pressure seal for high pressure and vacuum applications. The long term stability of the sensor offers an excellent choice for use in applications where the location of sensor makes maintenance difficult due to limited access.

The transmitter comes with an overload capacity of more than six times for nominal ranges less than 25 bar, and with respective burst pressure of ten times the range (see Table 1). Overload capacity is important when measuring on small ranges where pressure peaks can occur.

Installation

The transmitter consists of a sensing element together with a signal converter unit encapsulated in a body made of high quality stainless steel. All the mechanical parts exposed to the media are made of same material and welded together leaving no crevices to attract contaminants or process media residues.

Process connection is ISO228-G1/2A threads, male connector.

There are two different enclosures available:

- A short version for easy cable connection by an M12 connector
- A long version with cable gland and terminal connection.

The short version is made for applications where space is limited. The M12 connector is designed for tough applications and timesaving wiring (see Figure 1). The long version comes with an integrated connection box with an M20 cable gland covering cables with diameter from 6-12 mm (see Figure 3).

Cable requirement is 2 x 0.5 mm² twisted pair cable with Cu-screen. The Cu-screen shall be grounded in the terminal list or internal grounding clamp in the connection box (see Figure 4). On the monitoring side, the screen shall be grounded as near to the input channel in the monitoring cabinet/system as possible.

Power supply to the transmitter is 24 VDC nominal, but the transmitter will tolerate a variation from 11.5 VDC to 28 VDC from the power source. The allowable load is determined by the minimum power supply.

If the pressure transmitter is to be used in hazardous areas, a zener barrier has to be used to interface the transmitter to safe area.

Kongsberg Maritime can deliver detailed installation instructions and necessary installation material for various applications.

DRAWINGS AND INSTALLATION

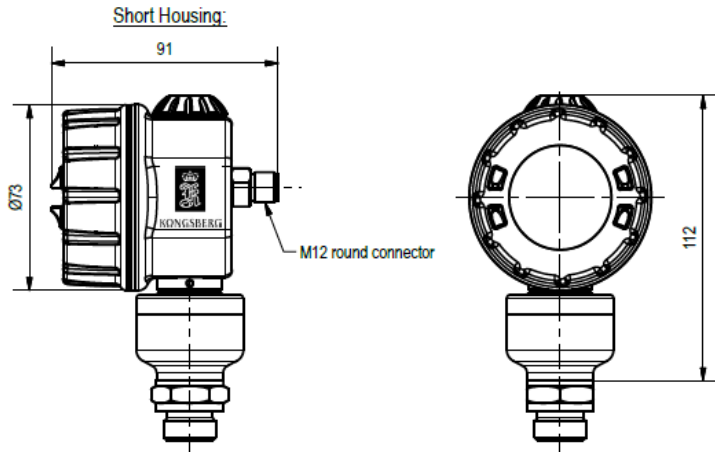

Figure 1: GT405 short version with M12 plug connector

Connection	Pin configuration	Color assignment ^a
Voltage supply for non Ex version DC 12 to 36 V for Ex version DC 12 to 28 V		1 L+ 3 L-
Output 4 to 20 mA two-wires Impressed current 4 to 20 mA in voltage supply		1+ 3-
Functional ground		4
NC		2

^a The following color assignment applies only to A-coded standard cables!

Figure 2: M12 plug pin configuration

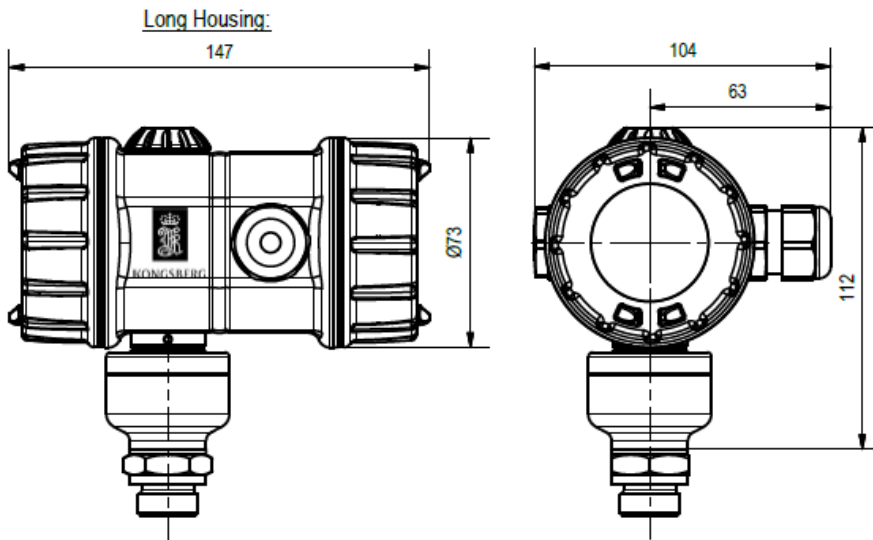

Figure 3: GT405 long version with EMC cable gland dimensioned for cable diameter 6 - 12 mm

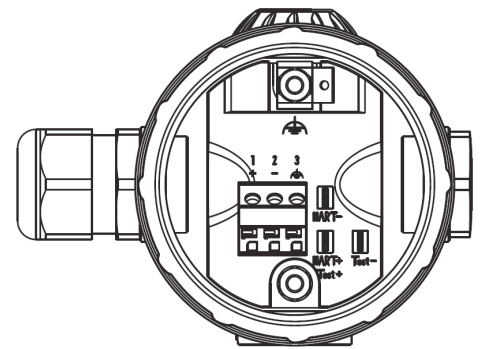

Figure 4: Cable connection terminals

TABLES

Table 1: Nominal measuring range, overload and burst pressure

Gauge pressure [bar]:

Nom. range	-0,6 to 0,6 bar	-1 to 2.5 bar	-1 to 4 bar	-1 to 25 bar	-1 to 100 bar	-1 to 600 bar
Overload capacity	6 bar	15 bar	30 bar	150 bar	300 bar	1200 bar
Burst pressure	12 bar	30 bar	60 bar	250 bar	400 bar	2000 bar

Sealed gauge and absolute pressure [bar]:

Nom. range	0 to 0,6 bar	0 to 2.5 bar	0 to 4 bar	0 to 25 bar	0 to 100 bar
Overload capacity	6 bar	15 bar	30 bar	150 bar	300 bar
Burst pressure	12 bar	30 bar	60 bar	250 bar	400 bar

SPECIAL CONDITIONS FOR SAFE USE

The system must be depressurized before assembly of the pressure transmitters.



Compliance with the Essential Health and Safety Requirements has been assured by compliance with: CENELEC EN 60079-0 : 2012 and CENELEC EN 60079-11 : 2012 and CENELEC EN 60079-26 : 2015

- The intrinsically safe circuit must be limited to overvoltage category I as defined in IEC 60664-1 and the circuits must be supplied exclusively from a certified intrinsically safe power source with the protection level "ia".
- Assignment between the max. permissible ambient temperature in the electronics enclosure, measuring temperature and temperature class:

Temperature class	T6	T5	T4	T3
Maximum permissible ambient temperature in top part of enclosure with electronics (°C)	-50 ... +50	-50 ... +65	-50 ... +85	-50 ... +85
Maximum permissible measuring temperature (°C)	+60	+70	+115	+175

- Assignment between the max. permissible ambient temperature in the electronics enclosure, measuring temperature and max. surface temperature:

Surface temperature (°C)	T105
Maximum permissible ambient temperature in top part of enclosure with electronics (°C)	-50 ... +60
Maximum permissible measuring temperature (°C)	+100

- In the temperature range of -40 °C ... - 50 °C the lid with inspection glass of the appliance has to be additionally protected against mechanical impact- respectively collision effect.

ORDER CODE

GT4 0 5 x x x xxx x x x xxx

OUTPUT SIGNAL
0 = 4-20mA / HART

DESIGN
5 = General use dry area, IP66/67, high precision

ACCURACY
(incl. Linearity, hysteresis and repeatability)
G = 0,30 % FRO -30 to 70°C
H = 0,10 % FRO 0,005%FRO/°C 0 to 60°C

ELECTRICAL AND CABLE CONNECTION
3 = M20 cable gland for diameter 6-12mm
6 = M12 round connector

INPUT AND ZERO POINT
G = Gauge (4mA at atm.pressure)
A = Absolute (4mA at 0 Bar Abs.)
C = Sealed Gauge (4mA at 0,8 Bar Abs.)
H = Sealed Gauge (4mA at 1,0 Bar Abs.)
K = Gauge (4mA at -1,0 Bar Atm.)
M = Gauge (4mA at -0,5 Bar Atm.)

OTHER
000 = NA (default if left blank)
XXX = Special request

CALIBRATION CERTIFICATE
0 = Without calibration certificate (default if left blank)
C = With calibration certificate

DISPLAY
0 = Without display (default if left blank)
D = With display

PROCESS CONNECTION, MATERIAL AND SEALING

Code	Connection	Material	Sealing
A	ISO 228-G1/2A	AISI316	AISI316
C	ISO 228-G1/2A	AISI316	Hastelloy C276

PRESSURE RANGE IN BAR

				0,1 ^{d)}
0,16 ^{d)}	0,25 ^{d)}	0,4 ^{d)}	0,6	1
1,6	2,5	4	6	10
16	25	40	60	100
160	250	400	600	

^{d)} Only for gauge

FEATURES

- Accuracy 0,1 % of FRO
- Low temperature drift
- Low long-term drift
- Excellent overload capacity
- HART compatible
- Body of AISI 316
- Rotary knob for simple operations
- ATEX Ex ia
- LCD display (optional)

TECHNICAL SPECIFICATIONS

Measuring range:	0.1 to 600 bar
Accuracy ¹ :	See order key
Temperature drift:	See order key
Comp. temp range ² :	See order key
Long term drift:	< 0,1 % /year (% of nom. range ³)
Output signal:	4 to 20 mA with Hart
Output current:	3,6 mA < I _o < 21,5 mA
Output current at fault:	I _o ≥ 21,6mA
Power supply:	24 VDC (11,5 to 28 VDC) depending on load resistance)
Load resistance:	0 to 1100 ohm depending on power supply
Ex classification:	ⓂII 1 G Ex ia IIC T6 to T3 Ga
Ex certification:	SEV 09 ATEX 0138X
Operating temperature:	- 45 °C to + 85 °C
Storage temperature:	- 45 °C to + 100 °C
Materials	
Material body:	AISI 316L
Material membrane:	AISI 316L / hastelloy C276
Protection grade:	IP 66/67
Weight:	Short version 0,55 kg Long version 0,85 kg
Safety data	
Max. input voltage:	U _i ≤ 28 V
Max. input power:	P _i ≤ 0,75 W
Max. input current:	I _i ≤ 115 mA
Max. internal capacitance:	C _i = 6 nF
Max. internal inductance:	L _i = 105 μH
Type approvals:	ABS, BV, CCS, DNV-GL, LRS, RINA, RMRS
Other approvals:	GOST, CEPEL



Accessories

Bracket for wall mounting:	375280
M12x1 PUR cable (3p), 2m angled:	375509
M12x1 PUR cable (3p), 2m straight:	375513

¹ Included non-linearity, hysteresis and repeatability

² Temperature drift within temperature compensated range. Not related to operating temperature

³ Nominal range of pressure element, see Table 1

⁴ Full Range Output (scaled range)

Specifications subject to change without any further notice.