

# MBR 144 MK3 OEM



KONGSBERG



## Mobile Broadband Radio

The MBR 144 MK3 OEM is a smart antenna designed for use in any application where long-range, resilient high-speed communication and high-capacity data transfer are essential for efficient and secure operations. The superior phase array technology with real-time electrical beamforming allows the MBR 144 MK3 OEM to steer the antenna beam in an omnidirectional sector ideal for moving assets. The MBR 144 MK3 OEM is compact and low-weight. It is designed for customer specific integration with a flexible form for an easy fit into existing platforms. The antenna connections are connector-based, thus the antennas can be adjusted to the customer specific design. The MBR 144 MK3 OEM is field-proven with a performance unmatched by conventional technologies.

### Built for mobile platforms

Whether mounted on high-speed platforms, unmanned systems or mobile command units, the MBR delivers resilient real-time communication in even the most dynamic environments. Its robust ad-hoc networking, continuous real-time beam steering that locks onto the far-end asset, ultra-low latency and automatic link optimization work together to maintain an uninterrupted data flow for fast-moving operations. The result is a radio system purpose-built for missions where extreme mobility, high data throughput and uncompromising reliability converge.

### Ultralong range

The MBR's advanced phased array technology with the precise narrow beam achieves reliable digital communication across ultralong distances - without relying on satellite or cellular infrastructure. Whether you are operating in remote coastal zones, in the air or across vast areas, the MBR delivers reliable, high-bandwidth connectivity where others drop off. Designed for long-range missions and distributed operations, the MBR keeps your team in sync and in control over unbeatable distances between your assets.

### GNSS denied operation

Built with resilience at its core, the MBR integrates independent, embedded network-timing and synchronization mechanisms that deliver stable, deterministic performance. By operating entirely without reliance on satellite-based navigation or timing sources, it removes the common vulnerabilities introduced by jamming, spoofing and other GNSS-targeted disruptions. Whether deployed in high-risk environments or regions with degraded or denied signal conditions, the MBR maintains interference-resistant, mission-critical connectivity — keeping operations secure, stable and uninterrupted when reliability matters most.

### Interference resistant beam steering

Based on its advanced phased-array architecture, the MBR generates real-time steerable narrow beams that preserve robust link integrity while significantly reducing susceptibility to jamming, interference and other hostile signal conditions. This enables the MBR to maintain full operational performance even in contested RF environments, sustaining reliable connectivity without degradation from intentional or unintentional interference.

### One system - countless applications

Designed with flexibility in mind, this communication system adapts to a wide range of operational needs. With multiple models and configurations available, it can be seamlessly integrated across aircrafts, vessels, ground vehicles, UAVs, USVs, UUVs and even personnel-worn setups. Whether supporting autonomous platforms, mobile teams or complex multi-domain missions, it delivers consistent, high-performance connectivity — no matter the platform or environment.

### Tailored for your demands

The MBR product range is built to meet the diverse demands of modern operations, offering units optimized for specific assets and mission profiles. Each system delivers seamless, high-capacity IP based data exchange, dependable performance and rugged construction — with no moving parts and no need for regular maintenance. Whatever the mission, wherever it takes place, there is always an MBR ready to connect your team.

### Extreme durability

With solid-state technology, precision manufacturing and no moving parts, the MBR is engineered for maximum reliability and minimal maintenance. Its rugged design ensures long-term durability, even in the harshest environments — so you can count on consistent performance, mission after mission. The MBR is field proven by many NATO countries.

## FEATURES

- Phased array wireless data link
- Ad hoc network operations
- Very long range with high data throughput
- For any mobile and unmanned platforms
- IP based data exchange
- GNSS denied/spoofed operation
- 56-bit link encryption embedded in hardware
- Frequency range 4400 – 5000 MHz
- Easy to install and operate
- Minimal maintenance
- No ITAR restrictions applies
- Classified as non-listed item
- Field proven by many NATO countries

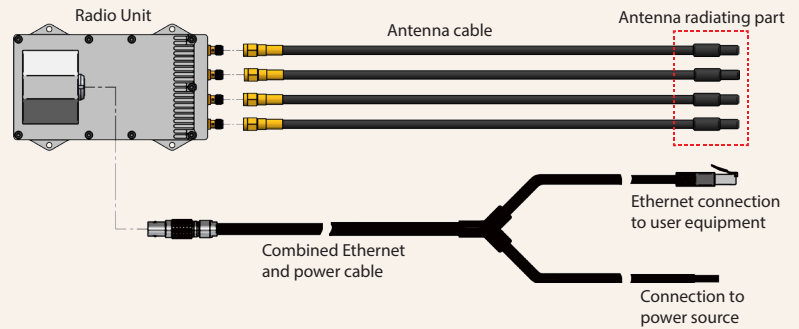

## Technical specifications

### MBR 144 MK3 OEM

#### Wireless specifications

Technology	Phased array/4 external antenna elements
Antenna coverage	Omni-directional/360 degrees azimuth
Frequency band <sup>1</sup>	4400 - 5000 MHz
Channel bandwidth	20 MHz
Antenna gain	Up to 6 dBi
EIRP	Up to 39 dBm
Modulation/polarization	GMSK/Vertical
Link encryption	56-bit symmetric key algorithm embedded in hardware
Wireless link rate	Up to 20 Mbps
User data throughput	Up to 16.5 Mbps

#### Interfaces

Data interface	Ethernet 10/100/1000 base-T
Connector	LEMO FGL.1B.308.CLLD72
Antenna connectors	4 x SMA

#### Management

User interface	Web (http)
API	C Library

#### Power specifications

Input voltage	24 VDC
Power consumption full TX	30 W max.
Power consumption RX	9 W

#### Weight and dimensions

Dimensions (HxWxL)	35 × 78 × 120 mm
Weight	260 g

#### Environmental specifications

Operating temperature	-30 °C - +55 °C
Operation humidity	20 - 100 % RH
Storage humidity	20 - 70 % RH
Ingress protection	IP20

#### Standards and regulations

RED directive 2014/53/EU conformity:	
• Product safety	IEC 61010-1/EN 61010-1
• Spectrum	ETSI EN 303 276
• EMC	ETSI EN 301 843-1, ETSI EN 301 843-7, IEC 60945/EN 60945
EMC	IEC 60945/EN 60945
Environmental	IEC 60945/EN 60945
Radio hazard standard	EN 50385

<sup>1</sup> Configurable range for the single 20 MHz channel

Specifications subject to change without any further notice.