



KONGSBERG

Instruction Manual

SPT and MPT 341 series

SSBL Positioning Transponder (SPT)

Multifunction Positioning Transponder (MPT)

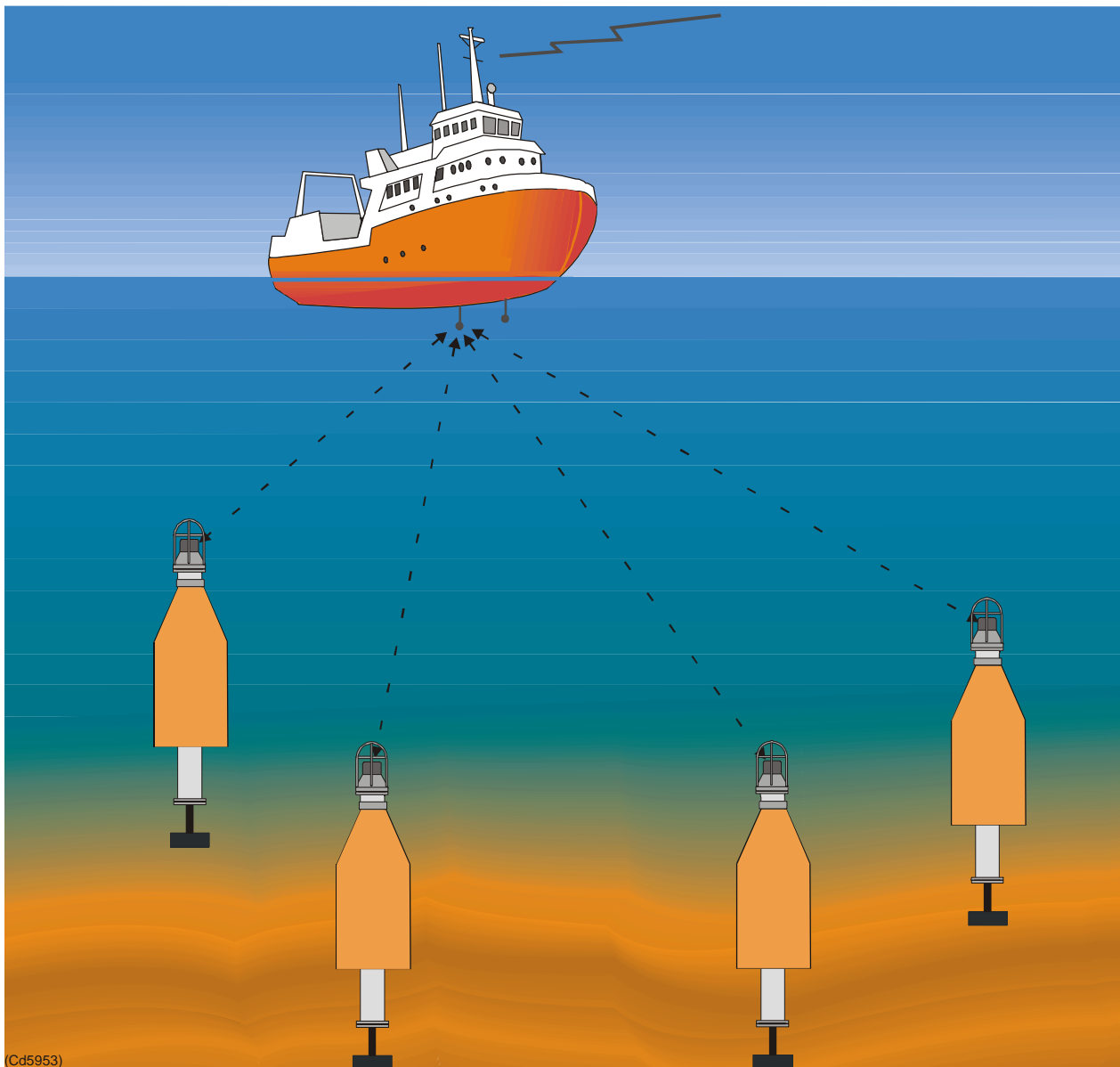

(Cd5953)

SPT and MPT 341 series

SSBL Positioning Transponder (SPT)

Multifunction Positioning Transponder (MPT)

This is the Instruction manual for the Kongsberg Maritime SSBL Positioning Transponder (SPT) and Multifunction Positioning Transponder (MPT) 341 series.

Warning

Due to safety rules, the safety information for transponder and transponder battery must be read before handling transponders or separate transponder batteries. Refer to:

- Safety information for transponder and transponder battery chapter on page 15.***

About this document

Rev	Date	Written by	Checked by	Approved by
A	Mars 2004	GM	SER	JEF
	Original issue.			
B	05.10.05	GM	SER	JEF
	Implemented SPT 341/RspSx 100 Vac SU. layout updated. Minor corrections in the text.			

© 2005 Kongsberg Maritime AS. All rights reserved.

No part of this work covered by the copyright hereon may be reproduced or otherwise copied without prior permission from Kongsberg Maritime AS.

The information contained in this document is subject to change without prior notice. Kongsberg Maritime AS shall not be liable for errors contained herein, or for incidental or consequential damages in connection with the furnishing, performance, or use of this document.

Kongsberg Maritime AS

Strandpromenaden 50
P.O.Box 111
N-3191 Horten,
Norway

Telephone: +47 33 02 38 00
Telefax: +47 33 04 47 53
www.kongsberg.com
E-mail: subsea@kongsberg.com



KONGSBERG

Contents

INTRODUCTION	1
Manual contents	1
How to handle a transponder	1
List of abbreviations	2
General description	2
Transponder identification	3
Applications	4
SPT specific applications	4
MPT specific applications	4
HPR and HiPAP compatibility	4
Available transponders	5
Transponder model identification principles	6
General	6
Model name	6
Model number	6
Options	6
Housing material	7
Transponder models description	8
Basic models	8
Versions	8
Auxiliary equipment	9
Beam patterns	10
TECHNICAL SPECIFICATIONS	11
Source level and receiver sensitivity	11
Common specifications	11
SPT 341/I	11
MPT 341/DuB	11
RspSx 110 Vac SU	12
RspSx 110 Vac	12
Split housing and transducer	12
Guiding collars	12
External connectors	13
SAFETY INFORMATION FOR TRANSPONDER AND TRANSPONDER BATTERY	15
Introduction	15
Product identification	15
Product name	15
Battery design	15
Battery chemistry	15
Battery cell manufacturers/types	16

Hazards identification	16
General	16
Danger of explosions	16
Noxious gases	17
First-aid measures	18
Fire-fighting measures	18
Personals protection	19
Handling	19
Introduction	19
Recovering a 'functioning' transponder	19
Recovering a 'failing' transponder	19
Handling a heated or self-heated transponder	20
Handling a transponder if the relief valve opens	20
Opening a transponder with defect/possible defect battery	21
Opening a 'functioning' transponder	21
Handling heated or self-heated separate battery	21
Storage	22
Ecological information	22
Disposal considerations	23
Transport information	24
OPERATION	25
General	25
Safety information about transponder and transponder battery	25
Connecting the battery	25
System set-up	25
Operation	25
Transponder in use	26
Pre-deployment checks	26
Mounting	26
Deployment	27
Ready for operation	27
Positioning of a transponder	27
Inclinometer sensors	27
Responder function	28
Replacement of the battery	28
Recovery	28
Storage	28
BATTERIES	29
General	29
Specification	29
Battery replacement	30
Battery capacity	30
Battery lifetime at operation	31

Lithium battery packs	31
Lithium battery storage	33
Alkaline battery pack	34
Alkaline battery storage	35
Rechargeable battery pack	36
Connecting the transponder battery	37
Procedure	37
Replacement of the transponder battery	38
TRANSPONDER CONFIGURATION	39
General	39
Frequency bands	39
Acoustic telemetry - basics	39
Switch settings - basics	40
HPR 400/HiPAP channels	40
HPR 400 system	40
HiPAP system	41
Acoustic coding principle	41
HPR 400 channels and positioning frequencies	42
HPR 300 channels	43
HPR 300 command function	43
HPR 300 frequencies and switch settings	43
Responder and external power functions	44
MAINTENANCE	45
General	45
Safety information for transponder and transponder battery	45
Dismantling the transponder	45
Replacement of circuit boards	47
Rx board, Tx board and Microcontroller board	47
Rx-amplifier matching board and motherboard	48
Replacement of the transducer	49
Remove the bottom end cap	50
Replacement of the battery	50
Transponder assembly	51
Source level adjustment	51
SPT 341/RspSx 110 Vac SU transponder - power module	52
MAIN PARTS	53
General	53
Transducer	54
Housing	54
Bottom end cap	54

Circuit boards	55
Transmitter board (Tx)	56
Receiver board (Rx)	58
Rx amplifier matching board	60
Microcontroller board	61
Switches	61
Motherboard	63
AUXILIARY EQUIPMENT	64
General	64
Floating rope	64
Auxiliary equipment supplied by Kongsberg Maritime	64
Guiding collar	64
SPARE PARTS	67
Introduction	67
Codes used	67
Accessories	68
Sensors	69
Batteries	69
SPT 341/I transponder	70
Complete transponder	70
Main modules	70
Accessories	70
SPT 341/RspSx 110 Vac SU transponder	72
Complete transponder	72
Main modules	72
Accessories	72
MPT 341/DuB transponder	76
Complete transponder	76
Main modules	76
Accessories	76
DRAWING FILE	78
Overview	78
Drawings	78
Outline dimensions	78
Wiring diagram	78
INDEX	85

INTRODUCTION

Manual contents

This manual describes all the Kongsberg Maritime SPT and MPT transponders, deep water use - 4000 m rated.

It provides technical specifications, safety procedures, operating instructions and maintenance procedures. It also includes spare parts lists for each of the transponder units.

How to handle a transponder

All the transponders described in this manual contains a lithium battery (as a standard).

Warning

***Due to safety rules, the transponder must be handle with care. Refer to:
- Safety information for transponder and transponder battery chapter on page 15.***



Figure 1 Special precautions to avoid personnel injury

List of abbreviations

HiPAP	High Precision Acoustic Positioning
HPR	Hydroacoustic Position Reference
LBL	Long Base Line
MF	Medium Frequency
MPT	Multifunction Positioning Transponder
ROV	Remotely Operated Vehicle
SPT	SSBL Positioning Transponder
SSBL	Super-Short Base Line
TP	TransPonder

General description

The SPT and MPT 341 transponder series are designed for use with the Kongsberg Maritime HPR and HiPAP systems. The following transponders are available:

- SPT 341 Inclinator transponder
- SPT 341 Responder with split transducer transponder
- MPT 341 Dual Beam transponder

All units are designed for ROV manipulator handling.

The transponder unit is designed with a modular construction such that the transducer, transponder electronics, battery pack and options (where applicable) can be replaced individually.

A transponder is normally a self-contained unit, its power being provided from an internal battery pack.

The transponder may be secured to a subsea structure using mounting brackets, or fitted with an anchor weight and buoyancy collar for location on the open seabed.

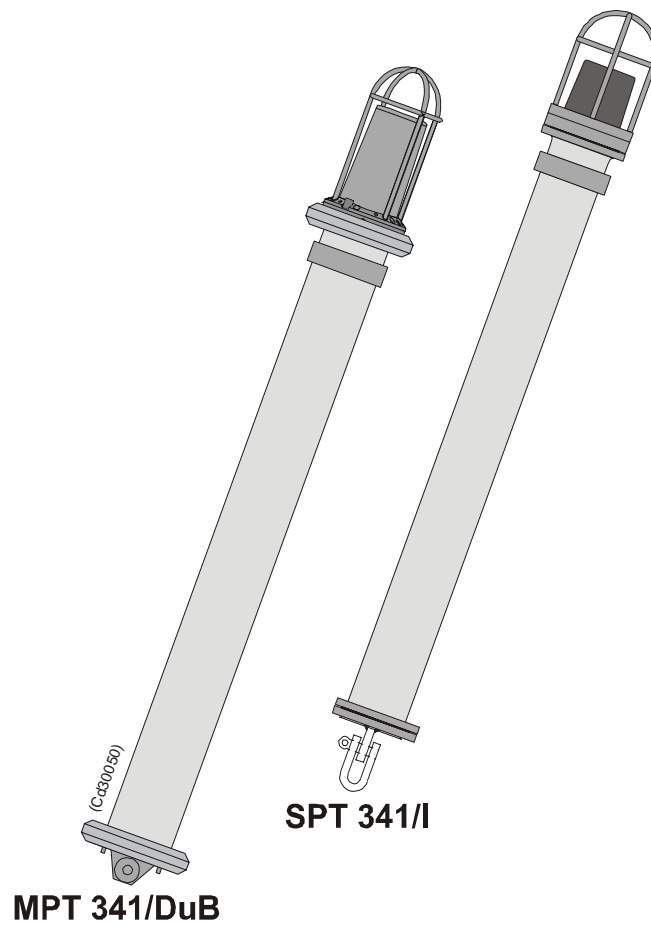

Figure 2 Examples of SPT and MPT 341 series transponders

Transponder identification

An identification clamp ring is tightened around the transponder body. This ring is engraved with:

- Transponder name
- Transponder registration number
- Unique serial number
- Frequency channel
- Type of battery

The figure shows an identification clamp ring for a transponder using channel 57 and includes a lithium battery. Name and serial number is engraved on the other side - see illustrations in the *Spare parts* section.

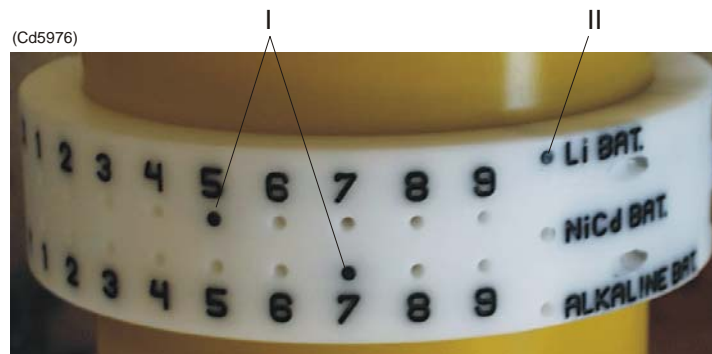

Figure 3 Example of identification clamp ring

If the TP configuration and battery is changed, the channel number (I) and the type of battery (II) can be altered by setting pegs into different holes in the clamp.

Applications

On interrogation, all models will reply with either a single- or a multi-pulse response. The response information depends on the application. All SPT and MPT models can be used in the following applications:

- SSBL positioning
- Telemetry of sensor data
- Sensor measurement

SPT specific applications

The following application can be used with the SPT only:

- Inclination measurement

MPT specific applications

The following applications can be used with the MPT only:

- LBL positioning
- Self positioning
- Range measuring

HPR and HiPAP compatibility

The the 341 transponders are compatible with the Kongsberg Maritime HPR 400 MF and HiPAP systems.

Available transponders

This manual covers the following transponders:

Transponder series	Model		Housing material
SPT 341			
	SPT 341/I	Inclinometer	Aluminium
	SPT 341/ RspSx 110 Vac SU	Responder with Short tube, backup battery, split transducer and 110 Vac power supply This transponder has 220 Vac as an option.	Aluminium
MPT 341			
	MPT 341/DuB	Dual Beam	Aluminium

Transponder model identification principles

General

The transponder name consists of the model name, the model number and any options included.

The name contains three letters followed by three digits. The letters after the numbers describe the option (see example below).

Model name

SPT = SSBL Positioning Transponder.

MPT = Multifunction Positioning Transponder.

Model number

The three digits describe:

Digit 1: frequency band

Digit 2: depth rating

Digit 3: beamwidth

The following are available:

1st digit	2nd digit	3rd digit
Frequency band	Depth rating	Transducer beamwidth
3 = 30 kHz	4 = 4000 m	1 = $\pm 15^\circ$

Options

The combination of letters after the number describes the options contained in the unit. The following options are available:

I	Inclinometer (one unit)
DuB	Dual Beam
RspSx110 Vac	Responder, Short tube, small backup battery and power supply
S	Split housing and transducer
U	Unlisted function which is custom specified

Housing material

Aluminium is the standard housing material.

Example: **MPT 341/ DuB**

The example given (MPT 341/DuB) therefore indicates that the transponder unit is an Multifunction Positioning Transponder, operating in the 30 kHz band, rated to 4000 meters depth, with a $\pm 15^\circ$ beamwidth, and including the Dual Beam function. The housing material is aluminium.

Transponder models description

Basic models

SPT 341

The SPT 341 transponder can only operate as an MF SSBL transponder to provide positional information. It is equipped with a $\pm 15^\circ$ beamwidth transducer.

MPT 341

The MPT 341 transponder operates as either an MF SSBL or LBL transponder to provide positional information. It is equipped with a $\pm 15^\circ$ beamwidth transducer.

Versions

/I

The **Inclinometer** (I) transponder is equipped with one set of inclinometers set at 90° to each other. It is used to measure and monitoring the angles of structures, such as:

- Riser angle measurement on oil platforms
- Monitoring underwater pipelines
- Template levelling

/DuB

The **Dual Beam** (DuB) transponder works as a dual beam transponder. It is used in LBL deep water positioning, and is equipped with a $\pm 15^\circ$ beamwidth transducer. It operates in the following two modes:

- Calibration
- Position

The array calibration is performed using a “doughnut-shaped” beam. When the calibration is completed, this beam is switched off, and the transponder is then operating in the position mode, with a $\pm 15^\circ$ beamwidth upwards.

/RspSx 110 Vac SU

The **Responder with Short tube and small backup battery** (RspSx 110 Vac) transponder is a combined responder and transponder.

This transponder has 220 Vac as an option.

The **Split housing and transducer (S)** transponder has separate housing (electronics unit) and transducer. The transducer has a 5 m long cable, to connect it to the housing.

Auxiliary equipment

→ *For auxiliary equipment supplied by Kongsberg Maritime, refer to page 64.*

Beam patterns

The figure shows beam pattern for the different transducer types; and $\pm 15^\circ$. The beam pattern shows the transmit / receive sensitivity in the different directions.

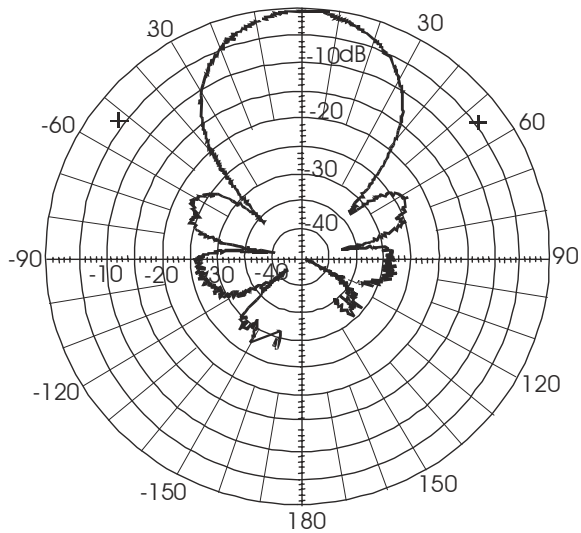

SPT 341
MPT 341/DuB vertical
Source level = 206

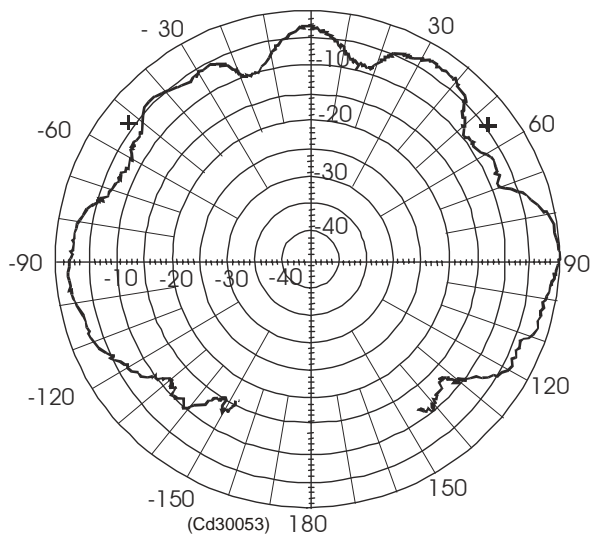

MPT 341/DuB horizontal
Source level = 190dB

Figure 4 Example of beam pattern

TECHNICAL SPECIFICATIONS

Source level and receiver sensitivity

Model series	Source level - max (4 steps of 3 dB)	Receiver sensitivity HIGH / LOW (2 steps)
SPT 341	206	100 / 106
MPT 341/DuB	Vertical: 206 Horizontal: 190	100 / 106

Common specifications

The technical details given in this paragraph are common for all the transponder types described in this manual.

Maximum depth rating	4000 meters
Housing material	Aluminium
Flange and transducer head	Aluminium/polyurethane
Operation temperature	0° to +30°C

SPT 341/I

→ *Outline dimension and weight, refer to page 78.*

One set of inclinometers.

Maximum detectable angles

HPR 300 channels	± 15 deg
HPR 400 channels	± 60 deg

Resolution

HPR 300 channels - pulse position telemetry	0.25 deg
HPR 400 channels - pulse position telemetry	0.1 deg
HPR 400 channels - full telemetry	0.02 deg
Accuracy, standard sensors	0.25 deg

MPT 341/DuB

Transducer beamwidth Dual Beam	Vertical: ± 15 deg Horizontal: ± 15 deg
--------------------------------	--

→ *Outline dimension and weight, refer to page 78.*

RspSx 110 Vac SU

RspSx 110 Vac

As in common specifications, except:

Maximum power consumption 110 Vac	7.5 W
Backup Lithium battery quiescent lifetime	130 days
External connector type	7-pins Gisma plug 10.00.2.07.1.10

→ *Outline dimension and weight, refer to page 78.*

Split housing and transducer

Transponder external connector type	4-pins Gisma plug 10.00.1.04.2.10
Transducer external connector type	4-pins Gisma plug 10.06.1.04.2.00

→ *Outline dimension and weight, refer to page 78.*

Guiding collars

Depth rating	4000 m
Material	Polyethylene
Colour	Black / White

→ *Outline dimension and weight, refer to page 78.*

External connectors

The **SPT 341/RspSx 110 Vac SU** - this model is delivered with a pigtail.

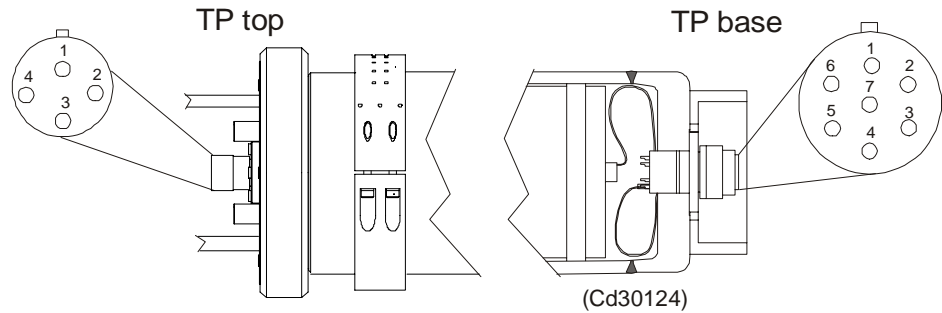

Figure 5 A 4 pin and a 7 pin external connector - layout

External connectors

The RspSx 110 Vac SU model has the following two external connectors:

- A 4 pins connector at the top, for transducer connection. The connector pin no. and function are shown in table 1.
- A 7 pins connector at the base for the responder and the external power function. The connector pin no. and function refer to table 2 on page 14.

Pin no.	Function
1	TD
2	TD
3	NC
4	NC

Table 1 RspSx 110 Vac SU top external connector

Pin no.	Function
1	External trigger line
2	External trigger GND
3	Note*
4	Note*
5	External 110 Vac
6	External 110 Vac
7	GND

Table 2 RspSx 110 Vac SU base external connector

Note

** Linked in the pigtail plug (pin no 3 and 4) to apply 10 V from the battery to the electronics.*

SAFETY INFORMATION FOR TRANSPONDER AND TRANSPONDER BATTERY

Introduction

This section includes transponder safety information for the Kongsberg transponders with lithium battery and separate Kongsberg transponder lithium batteries. It also includes emergency procedures.

Product identification

Product name

All Kongsberg Maritime transponders with a lithium battery, and separate Kongsberg Maritime transponder lithium batteries.

→ *Refer to Kongsberg Maritime transponder instruction manuals for the actual model.*

Battery design

A transponder lithium battery consists of several battery cells that are electrical connected, both in serial and parallel.

A transponder lithium battery consists of two separate parts:

- Receiver part (Rx)
- Transmitter part (Tx)

There are transponder batteries with different number of cells, voltages and capacity.

→ *Refer to Kongsberg Maritime transponder instruction manuals for the actual model.*

All transponder batteries include protection against short-circuits (re-settable fuses) and reverse current (diodes).

Battery chemistry

A transponder lithium battery consists of cells with chemistry:

Lithium Thionyl Chloride - Li/SOCl₂

- Negative electrode: Lithium metal (Li)
- Positive electrode: Thionyl chloride (SOCl₂)
- Electrolyte: Solution of lithium tetrachloroaluminate (LiAlCl₄) in thionyl chloride

Battery cell manufacturers/types

A transponder lithium battery consists of cells from one or two of the following types:

- Tadiran TL-2300
- Sonnenschein SL-780
- Saft LS 33600
- Saft LSH 20
- Sonnenschein SL-760

Hazards identification

General

Short-circuits, overheating, mechanical damage and exposure to water can start chemical reactions and high currents inside the transponder lithium battery. This can generate noxious gases and/or danger of explosions. The chemical reactions will continue without additional supply of oxygen, as the battery cells contain the necessary ingredients for maintaining the chemical reactions.

During operation, the battery is placed inside the transponder. Water ingress into the transponder can cause dangerous situations.

Danger of explosions

- If the cells that form the battery reach the critical temperature of 180° C, they will explode.
- **Water ingress** - The battery temperature will increase, caused by the high internal currents. The temperature can reach the critical point of 180° C.
- **Water ingress** - Electrolysis gives hydrogen. Together with oxygen, hydrogen can create oxyhydrogen gas inside the transponder (depends on the concentration). This gas is very inflammable/explosive.
- **Water ingress** - Chemical reactions in the battery will cause a pressure build-up inside the transponder. The transponder can explode if the inside pressure is high enough.
- If the transponder explodes, either the transducer or the bottom end cap will blow out, or the transponder becomes fragmented. This can cause serious damages on personnel and/or equipment.

- Some transponders have a relief valve that will prevent over-pressure. Noxious gases will then leak out of the transponder until the chemical reactions have stopped.
-

Note

The relief valve can be plugged, caused by products from the chemical reactions during an emergency as described above.

Noxious gases

- Thionyl chloride (SOCl₂)
- Sulphur dioxide (SO₂)
- Hydrogen chloride (HCl)
- Chlorine (Cl₂)

Signs and symptoms:

- Corrosive fumes with pungent odour, is very irritating to skin, eyes and mucous membranes. Over-exposure can cause symptoms of non-fibrotic lung injury and membrane irritation.

Inhalation:

- Lung irritant.

Skin contact:

- Skin irritant.

Eye contac:

- Eye irritant.

Ingestion:

- Tissue damage to throat and gastro/respiratory tract if swallowed.

Medical conditions:

- Eczema, skin allergies, lung injuries, asthma and other respiratory disorders may occur.

First-aid measures

All personnel that have been exposed to the noxious gases should immediately be seen by a doctor.

Inhalation:

- Remove from exposure, rest and keep warm.

Skin contact:

- Wash off skin thoroughly with water. Remove contaminated clothing and wash it before reuse.

Eye contact:

- Irrigate thoroughly with water for at least 15 minutes.

Ingestion:

- Wash out mouth thoroughly with water and give plenty of water to drink.

Fire-fighting measures

- **Cool down the battery with copious amounts of cold water.**
 - Transponder with lithium battery:
 - * Immerse the transponder in the sea for 12 hours or permanent.
 - * If this method is impossible, the transponder can be cooled down by use of a fire hose.
 - Separate transponder lithium battery:
 - * Immerse the battery in the sea for 12 hours or permanent.
 - * If this method is impossible, the battery can be cooled down by use of a fire hose.

Cooling down the battery with copious amount of cold water is the only way to reduce/stop the internal chemical reactions, or to limit the fire/explosions to as few battery cells as possible. The chemical reactions/fire will continue without additional supply of oxygen, so extinguisher like Lith-X will not work properly.

Applying water directly onto a battery, may develop oxyhydrogen gas, due to the possible electrolysis if the battery terminals are exposed to water. This gas is very inflammable/explosive. However, if the water cooling takes place out on deck, or in a storeroom with good ventilation, there will never be enough hydrogen gas to give oxyhydrogen gas (any gas will evaporate).

Personals protection

Fire/explosion:

- Use smoke-diving equipment.

Relief valve opens and noxious gasses come out:

- Use self-contained full-face respiratory equipment, and protective equipment of rubber or plastic.

Opening transponder with defect/possible defect battery:

- Use self-contained full-face respiratory equipment, and protective equipment of rubber or plastic.

Opening a *functioning* transponder:

- Use protective goggles.

Handling

Introduction

All personnel that handle transponders must know the transponder's status:

'Functioning' - 'Failing' - 'Unknown'

A Transponder with unknown status, must be handled as a transponder that is failing.

Recovering a '*functioning*' transponder

- All transponders recovered from the sea, should be placed in a safe place out on deck and controlled for minimum 2 hours:
 - Look for outer damages that could involve a water leakage.
 - The transponder housing temperature must be checked to verify a possible temperature increase in the lithium battery.

Recovering a '*failing*' transponder

- Handle as possible water ingress.
- Evacuate all unnecessary people.
- Recover the transponder with great precaution. Use a crane.
- No people should be near the transponder when it is lifted up on deck.
- Place the transponder in a safe place out on deck, shielded from people and vital equipment.

- Fasten the transponder in a crane, ready to lower it into the sea again.
- Control the transponder for minimum 2 hours:
 - Look for outer damages that could involve a water leakage.
 - The transponder housing temperature must be checked to verify a possible temperature increase in the lithium battery.

Failing and normal temperature:

- Take out the battery, see *”Opening a transponder with defect/possible defect battery”*.
- Refer to page 21.

Failing and increasing temperature:

- See *”Handling a heated or self-heated transponder”*.
- Refer to page 20.

Handling a heated or self-heated transponder

- Evacuate all unnecessary people.
 - Fasten the transponder to a rope and immerse it in the sea for 12 hours or permanent.
 - If this method is impossible, the transponder can be cooled down with copious amount of cold water. Use a fire hose.
 - Recover the transponder and control the temperature.
 - Repeat this until the temperature is low and stable.
 - The transponder can now be opened, see *“Opening a transponder with defect/possible defect battery”*.
- Refer to page 21.

Handling a transponder if the relief valve opens

- Evacuate all unnecessary people.
- Use necessary protection equipment.
- Fasten the transponder to a rope and immerse it in the sea for 12 hours or permanent.
 - If this method is impossible, the transponder can be cooled down with copious amount of cold water. Use a fire hose.

- Repeat this until no gases come out the check valve and the temperature is low and stable.
 - The transponder can now be opened, see “*Opening a transponder with defect/possible defect battery*”.
- Refer to page 21.
- Wash out chemical reaction products with water.

Opening a transponder with defect/possible defect battery

- The transponder is reported failing. There could have been water ingress in the transponder.
- Open the transponder in a safe place out on deck, shielded from people and vital equipment.
- Use necessary protection equipment.

Caution

Do not stand in front of transducer or bottom end cap, when opening the transponder.

- If there has been water ingress, and the battery is still heated:
 - Disconnect the battery from the transponder electronics, and then see “*Handling heated or self-heated separate battery*”

→ Refer to page 21.
- Wash out chemical reaction products with water.

Opening a 'functioning' transponder

- The transponder is reported functioning.
- Open the transponder in a safe place out on deck, shielded from people and vital equipment.

Caution

Do not stand in front of transducer or bottom end cap, when opening the transponder.

Handling heated or self-heated separate battery

- Evacuate all unnecessary people.
- Fasten the battery to a rope and immerse it in the sea for 12 hours or permanent.
 - If this method is impossible, the battery can be cooled down with copious amount of cold water. Use a fire hose.
- Wash out chemical reaction products with water.

Storage

Caution

A transponder that is failing, must be stored in a safe place out on deck, shielded from people and vital equipment.

A transponders that is functioning, and separate batteries can be stored indoors.

- Storage temperature:
 - Recommended storage temperature lies between 0° C and +25° C (max +50° C, min -55° C).
 - Storage relative air humidity:
 - Recommended relative air humidity is 40 to 70%.
 - A transponder/separate battery must not be stored directly in the sunlight.
 - A battery must not be exposed to water.
 - For long term storage, the battery must be disconnected from the transponder electronics.
 - Storeroom:
 - A solid room with study racks for transponders/separate batteries.
 - A room where no people are staying, or no vital equipment is placed.
 - Good ventilation.
 - Clearly identified.
-

Caution

A fire station, with fire hose (water), must be placed outside the storeroom.

Ecological information

A lithium thionyl chloride battery does not present environmental hazard.

Disposal considerations

- A lithium thionyl chloride battery does not contain any heavy metals, and is therefore not regarded as special waste (contains only biodegradable parts).
- A used transponder lithium battery often contains a significant amount of residual energy. It is the danger of explosion that presents a problem when disposing a battery.
 - Used batteries must therefore be handled with the same care as new ones.

Caution

For safe disposal, contact a company that has been approved to collect and dispose lithium batteries.

Transport information

All transponders with a lithium battery and separate transponder lithium batteries must be shipped in accordance with the prevailing regulations:

Transponder with lithium battery:

UN no. 3091, Class 9 Miscellaneous
(Lithium batteries contained in equipment)

Separate transponder lithium battery:

UN no. 3090, Class 9 Miscellaneous (Lithium batteries)

Transport:

Aircraft: IATA DGR

Sea Transport: IMDG Code

Railway: RID

Road transport: ADR

- Aircraft - Only new transponder lithium batteries can be transported by air.
- Aircraft - Transport of all transponders with new lithium battery and new separate transponder lithium batteries by air is only permitted onboard cargo aircraft. The goods must be clearly labelled:

CARGO AIRCRAFT ONLY

Caution

Transponder with lithium battery - During transport the lithium battery must always be disconnected from the electronics.

- Original transponder/battery cages must be used.

OPERATION

General

The transponders are designed for operation in water only.

Caution

At delivery, the transponder battery is disconnected, and must therefore be connected before deployment.

Safety information about transponder and transponder battery

→ *Refer to chapter on page 15.*

Connecting the battery

→ *Refer to page 37 for details.*

System set-up

All transponders are preset by the manufacturer. The channel setting may be changed if required. This can be done as follows:

- Use of internal switches, or
- use of acoustic telemetry from a HPR 400 or a HiPAP system. (A HPR 300 system can not send telemetry for this purpose.)

For information about set-up of a transponder, refer to *APOS Instruction manual / on-line help*.

Operation

The operation of a transponder is performed at the HiPAP/HPR topside Operator Station. For information regarding operation, refer to *APOS Instruction manual / on-line help system*.

Transponder in use

Caution

All personnel that handle transponders must know the transponder's status:

'Functioning' - 'Failing' - 'Unknown'

Caution

A Transponder with unknown status, must be handled as a transponder that is failing. For more information:

→ *Refer to "Handling" on page 19.*

Pre-deployment checks

Before you deploy the transponder, **you must:**

- 1 Check that the battery contains sufficient power for the proposed operation.
- 2 Perform a visual inspection of the transponder.
- 3 Perform a functional check to ensure it will operate correctly once it has been positioned on the seabed.
 - Ensure the transponder replies to the correct interrogation frequency.

The functional check can be performed as follows:

Transponder in water - use the APOS function check. When checking, lower the transponder on a rope over the vessel's side.

→ *Refer to the APOS Instruction manual / APOS on-line help.*

Transponder on deck - use the Transponder Test and Configuration Unit (TTC 400).

→ *Refer to the TTC 400 Instruction manual / TTC 400 Quick Reference Guide.*

Mounting

A transponder may be secured to a subsea structure using mounting brackets, or fitted with an anchor weight and buoyancy collar for location on the open seabed.

Deployment

Caution

During deployment prevent the transponder from slamming against other solid objects.

When you deploy the transponder:

- The unit must be positioned with the transducer upright.
- Ensure a clear line of sight between the transponder's head and the ship's transducer.

Ready for operation

Once deployed, the transponder is ready for operation. The sensors in your application will respond to requests from the HPR / HiPAP system, when they are enabled using telemetry.

Positioning of a transponder

Positioning of a transponder can be done in two ways:

- 1 The normal way is that the topside sends a request to the transponder, and the transponder answer the request after a given time delay.
- 2 The other way is with the transponder in beacon mode, then the transponder acts as an acoustic lighthouse. It transmits pulses regularly (with a given Pulse Repetition Interval) without being interrogated.

For more information, refer to *the APOS on-line help*.

Inclinometer sensors

The front direction is marked. This is illustrated in figure 6. The inclinometers' X and Y-axes are referenced to this mark.

- The Y-axis is parallel to the mark and perpendicular to the longitudinal axis of the unit.
- The X-axis is perpendicular to both the longitudinal axis and the Y-axis.

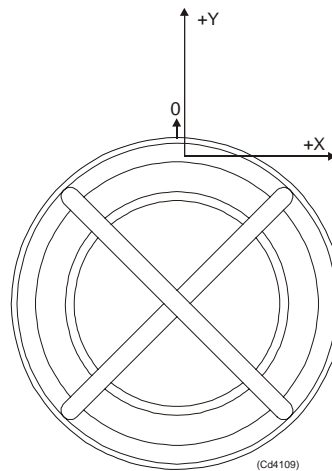

*Figure 6 Top view of the inclinometer transponder
- showing the front direction*

Responder function

To activate this function, the transponder must be connected directly to the HPR / HiPAP system via a cable.

- The responder function is automatically initiated by the presence of a valid “Trigger” pulse. When you provide a valid trigger pulse from the HPR / HiPAP system, the responder will reply on the previously selected channel.

Replacement of the battery

→ Refer to page 38 for details.

Recovery

After recovery, wash the unit thoroughly in fresh water to dissolve any salt deposits and clean off any sand or silt. If available, an high pressure hose may be used.

→ Refer to “Handling” on page 19.

Storage

→ Refer to “Storage” on page 22.

BATTERIES

General

The following battery types are available:

- Lithium (standard) (L)
- Alkaline (A)
- Rechargeable (N)

The transponders are normally self-contained with power. The standard battery is a lithium battery. It is used to ensure long life.

A battery consists of two sections, one for the receiver (Rx) and one for the transmitter (Tx).

→ *Safety information for battery, refer to the chapter on page 15.*

Specification

The battery specification includes:

- battery type
- Rx/Tx voltage
- number of battery cells used for Rx / Tx

Example: L10/36 (15/40)

The example given L10/36 (15/40), therefore indicates that this is a Lithium battery, with Rx voltage = 10 V / Tx voltage = 36 V. The Rx section comprises 15 battery cells, and the Tx section comprises 40 battery cells.

Battery replacement

The L10/36 (15/40) Lithium battery may be replaced by:

- the Alkaline battery A10/36 (24/24),
or
- the Rechargeable battery N10/36 (18/30).

An overview of the capacities of these batteries are presented in the table below. A more detailed specification is presented on the following pages.

Battery capacity

	Lithium	Alkaline	Rechargeable
Battery Type no.	L10/36 (15/40)	A10/36 (24/24)	N10/36 (18/30)
Maximum continuous on-time	180 days	71 days	16 days
Quiescent time	930 days	301 days	90 days
No. of replies, low source level	6.4 million	1.44 million	0.72 million
No. of replies, max source level	1.6 million	0.36 million	0.16 million

- The Alkaline battery capacity is approx. 20% of the Lithium battery.
- The rechargeable battery capacity is approx. 10% of the Lithium battery.

Battery lifetime at operation

The transponder has a battery monitoring function. For information on how to operate this function, see *the System operator manual / APOS on-line help*.

- Two pings are required to transmit the depth and compass information.
- Three pings to transmit the inclinometer information.
- When the transponder is set to HPR 400, and used for full telemetry, seven pings are required for each telegrams. The battery lifetime could therefore be much reduced from that stated in the figures below. However each reply is counted up and can be available to the operator.

The battery status presented in the APOS window is given at **High** source level.

Note

When the battery is disconnected, the battery status will be lost. When the battery is re-connected, the battery status reading will indicate 100% (as for a new battery). To keep track of the consumption, you are advised to make a note of the battery status before disconnecting.

The figures in this section indicating the respective battery lifetime, shows the lifetime based on 10 ms pulse length.

Lithium battery packs

To calculate the battery status, use the following equations:

- Max source level = $\frac{High}{2}$
- Low source level = $High \times 2$
- Min source level = $High \times 4$

Battery type	Transponder type
L 10/36 (15/40)	SPT 341/I MPT 341/DuB
L 10/40 (3/11)	SPT 341/RspSx 110 Vac SU

→ Battery specification, refer to page 29.

The figures show the lifetime based on 10 ms pulse length.

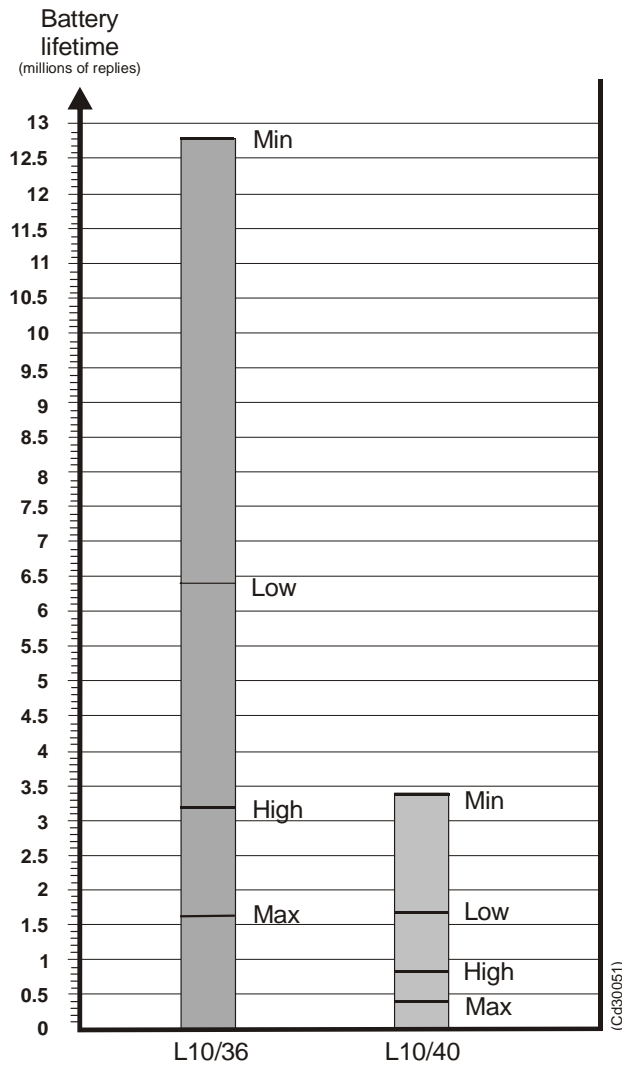

Figure 7 Battery lifetime at operation

Quiescent lifetime:

This is the total time the transponder can listen for interrogation pulses. After this time the transponder will not be able to reply.

Max continuous on time:

This is the maximum time the transponder can be continuously in operation, receiving and transmitting. If a low interrogation rate is used, this time may be consumed.

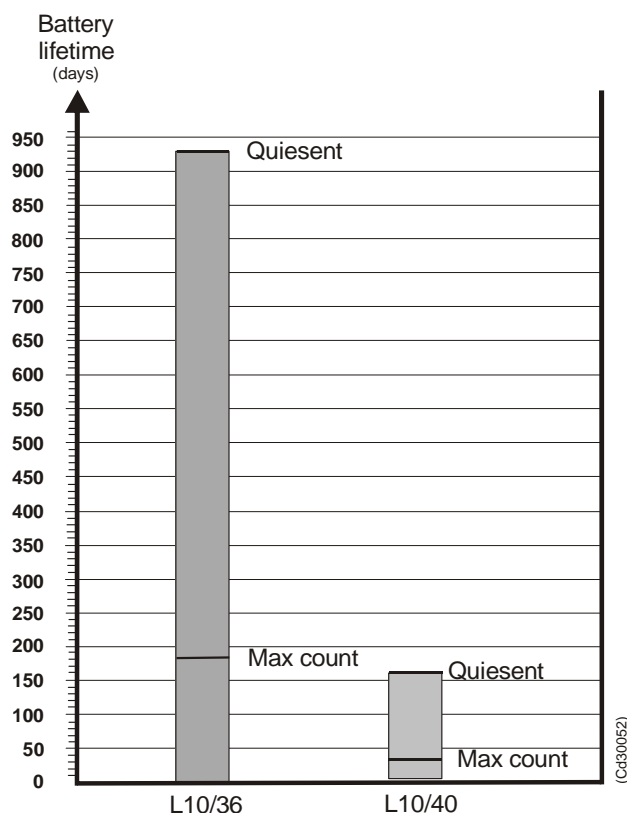

Figure 8 Battery lifetime at quiescent state

Lithium battery storage

→ Refer to “Storage” on page 22.

Self-discharge depends on the temperature. The higher the temperature the greater the self-discharge over time.

Shelf lifetime:

The batteries may be stored for up to 10 years with little loss of capacity. The losses are approximately according to the figures below (room temperature):

Capacity loss: 1st year - 3%

Next 9 years - 1.5% per year

Note

Total capacity loss over 10 years will therefore be approximately 15%.

Alkaline battery pack

An alkaline battery, the Battery Pack A10/36 (24/24) is available. This battery pack may be used as a replacement for the transponder battery, L10/36 (15/40).

→ *Battery specification, refer to page 29.*

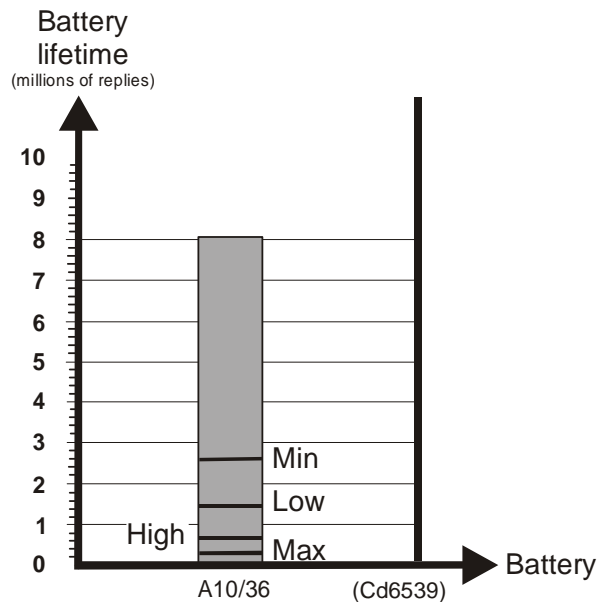

Figure 9 Battery lifetime at operation

Quiescent lifetime

This is the total time the transponder can listen for interrogation pulses. After this time the transponder will not be able to reply.

Max continuous on time

This is the maximum time the transponder can be continuously in operation, receiving and transmitting. If a low interrogation rate is used, this time may be consumed.

Battery lifetime at quiescent state

Max continuous on time:	71 days
Quiescent lifetime:	301 days

Alkaline battery storage

If the unit is not to be re-deployed in the near future, store it in a suitable environment.

Self-discharge depends on the temperature. The higher the temperature the greater the self-discharge over time.

Recommended storage temperature is room temperature or lower.

Shelf lifetime:

If the battery is stored in a dry place, (relative humidity < 65%), and with room temperature between 10 to 21 deg. C, up to 80% of initial capacity is still attainable after 4 years.

Caution

The batteries must be stored in an upright position.

Rechargeable battery pack

The transponders can be used with a rechargeable Nickel Cadmium (NiCd) battery, the Battery Pack N10/36 (18/30). This battery pack may be used as a replacement for the transponder battery, L10/36 (15/40).

→ *Battery specification, refer to page 29.*

The Battery Pack N10/36 (18/30) and battery charger is described in a separate manual.

→ *Refer to the BNC 1036 Instruction manual (doc. no. 164039).*

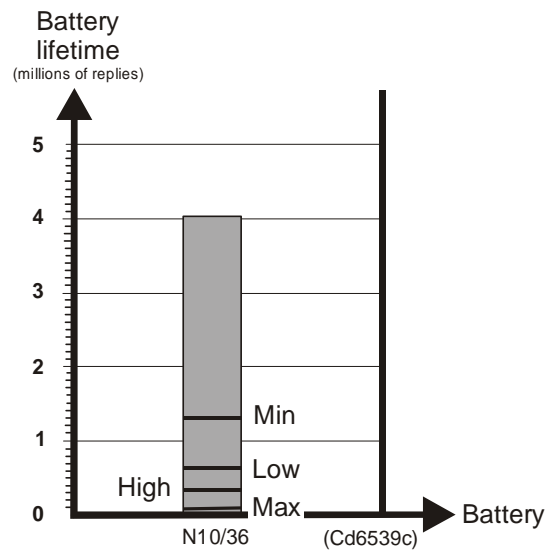

Figure 10 Battery lifetime at operation

Battery lifetime at quiescent state

Max continuous on time:	16 days
Quiescent lifetime:	90 days
Number of charge/discharge cycles:	250

Connecting the transponder battery

Procedure

To connect the battery, the unit must be opened.

→ Refer to page 45 for details.

- 1 Grab the connector firmly using both hands. Press the connector onto the battery plug.
 - When connecting the battery, listen for the transponder initialization:
 - **Three bursts** should be transmitted **at a rate of one per second**.
 - If no **bursts** are heard, disconnect the battery immediately, and wait minimum 20 sec. before connecting / reconnecting it again.
- 2 When the battery is correctly connected, assemble the transponder.
- 3 Check that the unit is correctly assembled and sealed.
- 4 Perform a functional check before deployment, to ensure it will operate correctly once it has been positioned on the seabed.
 - The functional check is performed at the Operator Station.
 - When checking, lower the transponder on a rope over the vessel's side.
 - Ensure the transponder replies to the correct interrogation frequency.

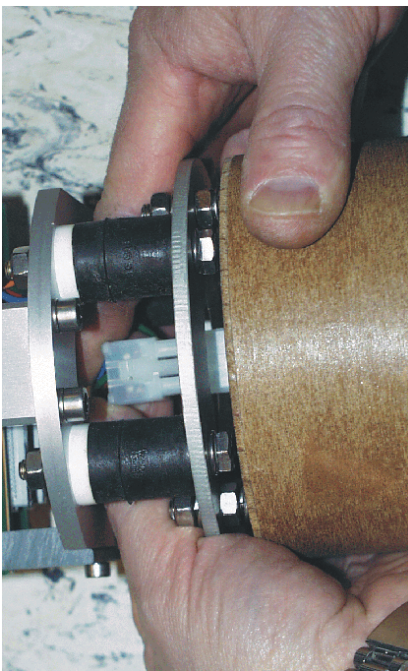

(C05937)

Figure 11 Connecting the battery

Replacement of the transponder battery

To replace a Lithium battery / rechargeable battery, follow the procedure below:

To replace the battery, the unit must be opened.

- 1 Unplug the connector from the battery by (see figure below):
 - Support the connector with your left hand and use a screw driver to press the release knob, as you pull out the connector.
- 2 Remove the four nuts and locking washers holding the battery to the chassis.
- 3 The battery can now be removed from the chassis.
- 4 Replace the battery pack in the reverse order, as follows:

- Mount the four nuts and locking washers holding the battery to the chassis.

→ Refer to figure on page 38.

- 5 Connect the battery.

→ Refer to figure on page 37.

- 6 Assemble the transponder.

Note *Replace the used silica-gel bag with the new bag delivered with the battery.*

Note *When the battery is connected / disconnected the electronics is Reset.*

Note *After Hard reset / Reset, Tx power is set to:*

HPR 400 = HIGH

HPR 300 = MAXIMUM

→ Refer to procedure on page 38.

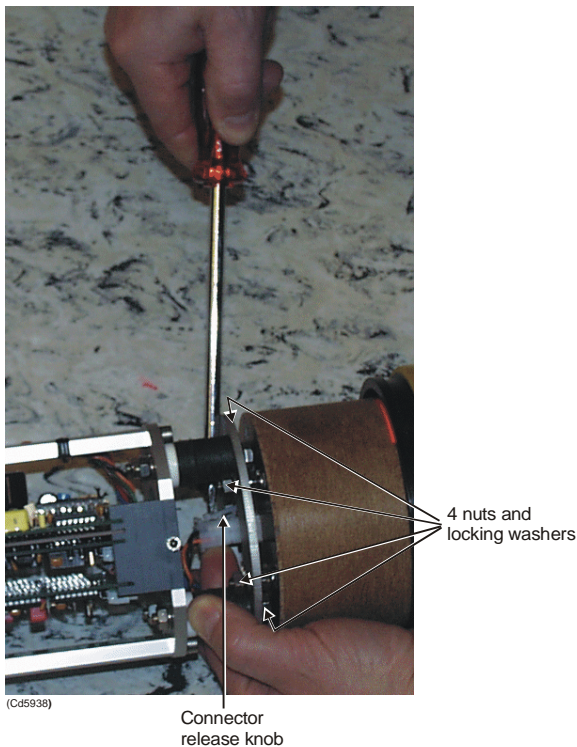

Figure 12 Battery connector and mounting screws

TRANSPONDER CONFIGURATION

General

All transponders are configured by the manufacturer. The configuration may be altered if required. The procedure to perform alterations will depend on the HPR / HiPAP system in use.

A transponder can operate with the following topside systems:

- HiPAP
- HPR 400 series
- HPR 300 series
- Each transponder series is dedicated to a specific frequency band.
- Altering the configuration, switching between the operating systems or changing the channel settings is done by:
 - Acoustic telemetry.
(A HPR 400 or a HiPAP system is required).
 - Use of internal switches.
(Located on the microcontroller board).
- A large number of transponder channels are available (depending on the selected system) to prevent interference between transponders, if several are located in the same area (a channel being an interrogation and reply frequency combination).

Frequency bands

The transponders described in this manual use the following frequency band:

Transponder	Frequency band number
SPT 341	B 1 - (30 kHz)
MPT 341	B 1 - (30 kHz)

Acoustic telemetry - basics

For information on how to use acoustic telemetry in the HPR 400 and the HiPAP systems.

→ *Refer to the Standard command reference chapter in the System operator manual / APOS on-line help.*

Switch settings - basics

The switches for frequency and channel set-up are located on the microcontroller board. The set-up must therefore be done before unit installation, while the unit is open. The following switches are available; a 4-bit DIL switch and two 16-position rotary switches.

→ Ref paragraph on page 61.

The set-up is described in the figure below and the switches are used as follows:

- The DIL switches (S1 - four switches) select the system of operation.
- The rotary switches S2 and S3:
 - For the HPR 400 and the HiPAP systems - select the transponder operating frequency and channel.
 - For the HPR 300 series - set the interrogation frequency and command address.

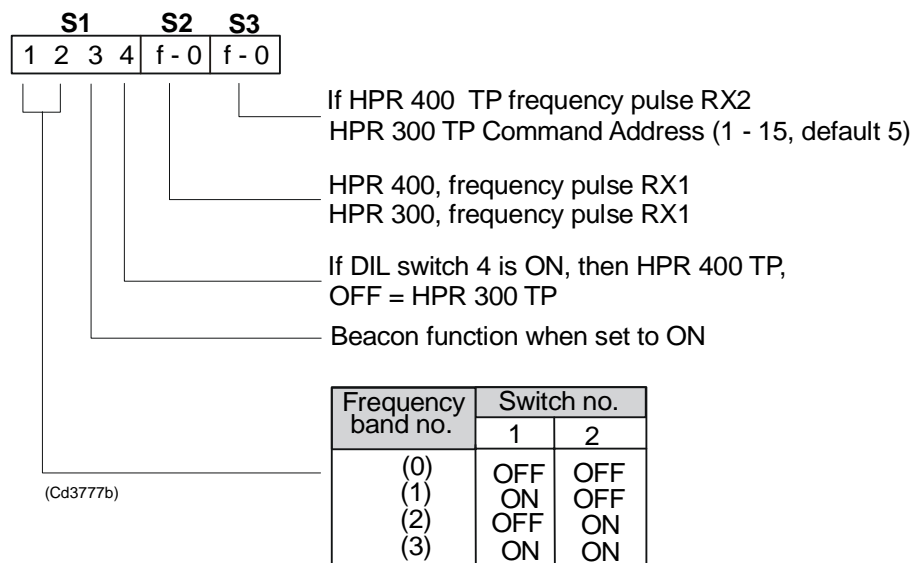

Figure 13 Microcontroller board - switch settings

HPR 400/HiPAP channels

HPR 400 system

The HPR 400 channel operation is the default. When set to HPR 400, the transponder executes all the commands for LBL and SSBL operation and subsea ranging. It also has an incorporated telemetry system.

HiPAP system

A HiPAP system uses the same channel working principle as a HPR 400 system. The following paragraphs therefore describe only the principles for a HPR 400 system.

Acoustic coding principle

The telemetry link uses a burst of seven pulses, all with different frequencies, transmitted in a sequence to make up a message. The coding principle is called “Factorial coding”, and has a total of 5040 combinations. 4096 of these are used for defining a 12-bit message, while the remaining; 4097 to 5040, are spare. The spare combinations may be used for other messages such as ASCII transmissions and special single messages.

A complete telegram is constructed by sending several messages in sequence.

HPR 400 channels and positioning frequencies

The number of channels available with an HPR 400 system depend on the transponder type used.

→ *An overview of available channels and operating frequencies, is given in the APOS on-line help.*

The HPR 400 system interrogates the transponders by transmitting two pulses with frequencies according to the protocol. The transponder reply is determined by the second interrogation pulse.

→ *Refer to figure on page 42.*

The HPR 400 system interrogates the transponders by transmitting two pulses with frequencies according to the protocol. The transponder reply is determined by the second interrogation pulse (see figure below). When the first interrogation pulse is an odd number (o) the reply is 250 Hz higher than it is when the pulse is an even number.

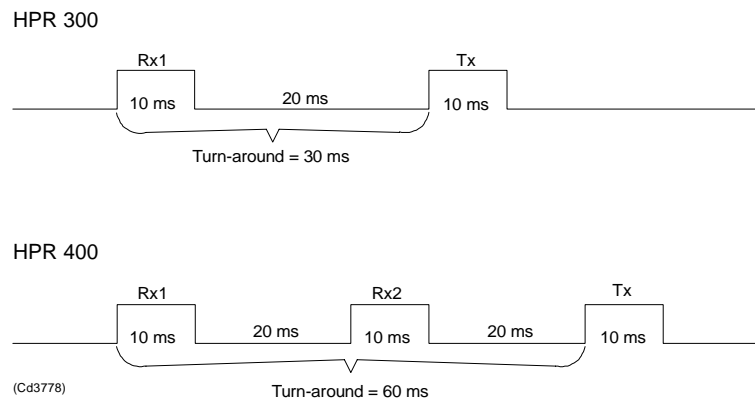

Figure 14 Transponder reception and transmission signal timing diagram

A total of 56 positioning frequency channels are available.

- Rx frequencies used are: 21.000 - 24.500 kHz.
- Telemetry frequencies used are: 25.000 - 26.500 kHz, at 250 Hz intervals.
- Tx frequencies used are: 27.000 - 31.500 kHz.

→ *An overview of available channels and operating frequencies, is given in the APOS on-line help.*

The switch settings for the SPT and MPT 33x series are:

DIP switches				
HPR	S1-1	S1-2	S1-3	S1-4
HPR 400	On	Off	Off	On
Rotary switches				
HPR 400	S2		S3	
	Set to the first digit of the desired channel number - Rx 1.		Set to the second digit of the desired channel number - Rx 2.	

Table 3 HPR 400 switch settings

HPR 300 channels

An HPR 300 system interrogates the transponders by transmitting one pulse with frequency according to the protocol.

→ Refer to figure 14.

The channels available are listed in table 4.

HPR 300 command function

The HPR 300 command function principles are the same for all the transponders described in this manual. In a HPR 300 system, the command system uses a combination of “Frequency shift keying” and “Pulse position coding”.

The commands are transmitted as a series of tone bursts, two frequencies being required to transmit the range of commands to each transponder. These are:

- An Individual Interrogation Frequency (IFF) - specific to the particular transponder.
- A Common Command Frequency (CCF) - common to all transponders. The CCF is 20.000 kHz.

The command information is contained in the delay between the IFF and the CCF signals, and in the CCF signal’s repetition period.

HPR 300 frequencies and switch settings

The number of channels available with an HPR 300 system depend on the transponder type used. This is specified in the following paragraphs.

→ An overview of channels and operating frequencies, see also the APOS on-line help.

The HPR 300 system uses the Common Command Frequency (CCF) of 20 kHz, and has a total of 14 channel numbers (frequency combinations) available.

Switch S2 setting	Transponder channel number	Operating frequencies (kHz)	
		Interrogation (TP Rx)	Reply (TP Tx)
1	B01	20.492	29.762
2	B02	21.552	30.488
3	B03	22.124	31.250
4	B04	22.727	31.847
5	B05	23.364	32.468
6	B06	24.038	27.173
7	B07	24.510	27.777
8	B08	25.000	28.409
9	B09	26.042	29.070
A	B11	21.552	27.173
B	B22	22.727	28.409
C	B33	23.923	29.762
D	B44	25.126	31.250
E	B55	26.455	32.468

Table 4 HPR 300 frequencies and switch settings

Referring to figure 13, the HPR 300 switch settings are:

DIP switches				
HPR function	S1-1	S1-2	S1-3	S1-4
HPR 300	On	Off	Off	Off
HPR 300- Beacon function	On	Off	On	Off
Rotary switches				
HPR 300	S2		S3	
	Set to the interrogation frequency.		Set to the command address default setting - position 5.	

Table 5 HPR 300 switch settings

Responder and external power functions

To initiate the responder and the external power function, the unit must be connected to a topside system via a cable. The pin allocations for of the unit's external connector:

→ Refer to page 13.

MAINTENANCE

General

No maintenance is normally required, apart from washing the unit. To change the battery pack, the unit must be dismantled.

Safety information for transponder and transponder battery

→ *Refer to chapter on page 15.*

Dismantling the transponder

The procedure for opening the pressure housing is identical for the all types of transponders described in this manual.

Pressure housing assembly:

The pressure housing comprises the cylinder body (housing), the transducer head and bottom end cap. The transducer head comprises of the transducer and the transducer cage. The transducer head has a screwed flange. The transducer head and the bottom end cap are both sealed into the housing, using two O-rings and a backup ring, and secured by six socket-head screws.

→ *An example of pressure housing assembly is shown in figure on page 47.*

To remove the electronics chassis and battery pack from the housing, follow the procedure below:

Before you open the unit:

- 1 Wash the unit thoroughly in fresh water, and dry off any moisture on the outside.
- 2 Place the transponder horizontally on a flat, clean work-bench, and support it so it can not roll off.

Opening the unit:

- 1 Remove the six socket-head screws that secure the transducer head into the housing.
- 2 Screw the same screws into the threaded holes in the transducer head till they meet the housing flange.
- 3 Tighten the screws a little at a time to extract the transponder head out of the housing.

Note *If the transponder is fitted with a release unit or a responder trigger connector, care must be taken to ensure that the wires connected to the release unit and battery pack are not damaged when withdrawing the chassis.*

Note *DO NOT attempt to "unscrew" the transducer from the housing as the internal wiring and circuitry can be damaged.*

Note *DO NOT use a screw-driver or similar tool in an attempt to lever the transducer out. This will damage the sealing surfaces resulting in water penetration.*

- 4** Support the end cap as it is withdrawn. Once the O-ring is clear of the housing, the transducer and electronics chassis may be removed.
- 5** There is a wire from the release mechanism or the responder connector (whichever is fitted) to the base of the battery pack. Disconnect this wire from the battery pack before attempting to remove the chassis too far from the transponder housing.

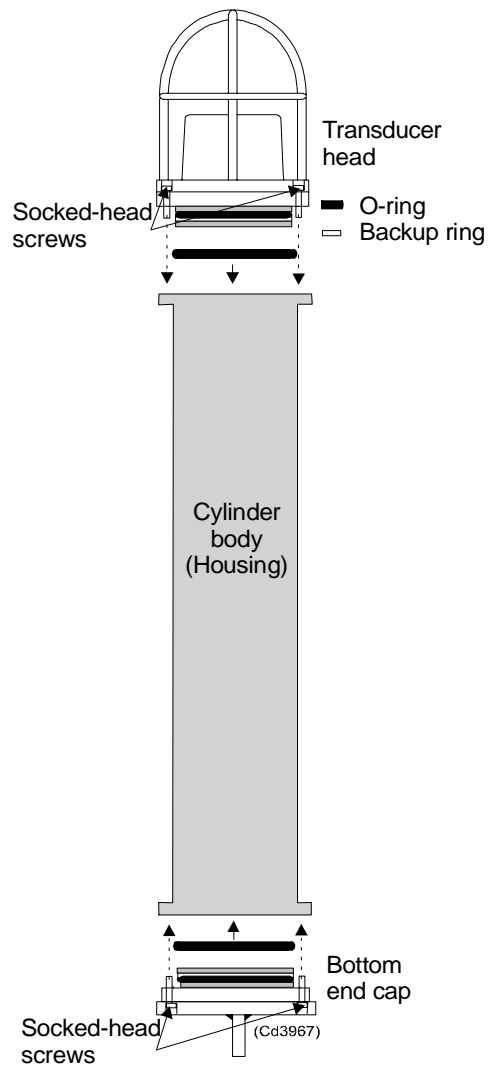

*Figure 15 SPT 341
pressure housing assembly*

Replacement of circuit boards

Rx board, Tx board and Microcontroller board

To replace one of these circuit boards, follow the procedure below:

- 1 Open the transponder.
→ Refer to paragraph on page 45.

- 2 Short together pins 3 and 6 in the plug connected to the electronics chassis, to discharge the transmitter capacitors.
- 3 Unscrew the plastic locking devices. The appropriate board can now be removed from the chassis.

Note

The Microcontroller board and Rx board are interconnected via a flat cable.

- 4 Mount the new circuit board and tighten the locking devices. Take care not to over-tighten the locks.
 - 5 Assemble the transponder.
- *Refer to paragraph on page 51.*

Rx-amplifier matching board and motherboard

To replace one of these circuit board, follow the procedure below:

- 1 Open the transponder.
- *Refer to paragraph on page 45.*
- 2 Remove the soldering at the connections. Remember to mark the wires.
 - 3 Unscrew the four screws holding the board. The appropriate board can now be removed from the chassis.
 - 4 Assemble the transponder.
- *Refer to paragraph on page 51.*

Replacement of the transducer

The transducer is sealed in the transducer cage. The transducer is a sealed unit and can not be opened. If the unit is not working, the whole unit must be replaced. To replace the transducer follow the procedure below:

- 1 Open the transponder.
→ Refer to paragraph on page 45.

Warning

Do not try to unscrew the two sealing screws on each side of the transducer flange (see figure on page 49).

- 2 Remove the complete transducer head.
 - For an inclination transponder, it is important to mount the 0-mark on the electronic chassis top-plate according to the 0-mark on the transponder head.
- 3 Assembly is basically the reverse of dismantling.

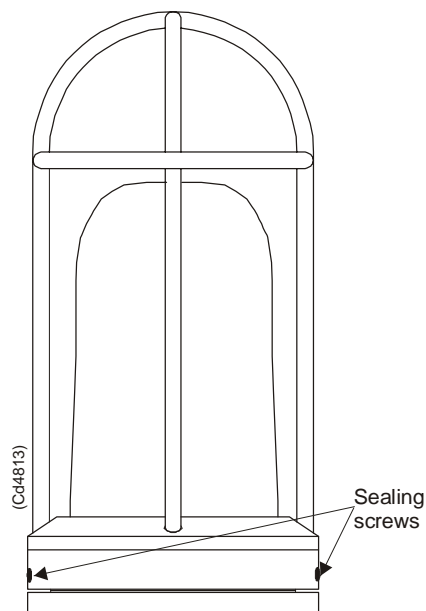

Figure 16 Transducer head, indicating the two sealing screws

Remove the bottom end cap

The end cap is sealed into the transponder housing. A number of socket-head screws are positioned around the release unit flange. Six of these hold the release unit. The procedure describes how to remove the release unit:

- 1 Remove the six socket-head screws that secure the release unit into the housing.
 - The screws where the heads are flush with the surface of the mechanism flange.
- 2 Hold the transponder securely, and agitate the release unit back and forth in the tube to break the seal.
- 3 Pull the release unit out. The unit should seal tightly into the housing, so some force will be required to withdraw it. There are no threaded holes for assistance at the base end, so care must be taken when using force.
→ *Ref paragraph on page 45.*
- 4 Pull the release unit out. The unit should seal tightly into the housing, so some force will be required to withdraw it. There are no threaded holes for assistance at the base end, so care must be taken when using force.

Note *A 1,3 m length of cable is connected between the release unit and the battery pack. Ensure this cable is not damaged when withdrawing the unit.*

Note *DO NOT attempt to "unscrew" the unit from the housing as the internal wiring and circuitry can be damaged.*

Note *DO NOT use a screw-driver or similar tool in an attempt to lever the unit out. This will damage the sealing surfaces resulting in water ingress.*

-
- 5 The release mechanism may now be removed. Once the O-ring is clear of the housing, it will be loose.
 - 6 Disconnect the release unit from base of the battery.

Replacement of the battery

→ *Refer to page 38 for details.*

Transponder assembly

To replace the electronics chassis and battery pack into the housing, follow the procedure below:

Before you start:

- 1 Inspect the O-rings and backup rings for damage. If in doubt, or if they have been used for more than one year, they should be replaced.
- 2 Place the new bag of silica-gel desiccant into the housing to absorb any humidity that may have entered the unit while it was open.
- 3 Ensure the mating surfaces and O-rings and backup rings are *completely* clean, then wipe a thin film of silica-gel over the rings and mating surfaces.

Assembling:

- 1 Carefully insert the chassis into the housing. Do not allow the circuit boards to knock against the housing, and ensure no wires are trapped between the chassis and the housing or left protruding from the housing.
- 2 Ensure the bag of silica-gel is positioned such that it will not prevent the chassis from fully entering the housing.
- 3 When the O-ring on the end cap meet the lead-in chamfer at the entrance to the housing, support the base of the transponder unit and push firmly on the transducer cage. Ensure the O-ring compress easily as the end cap enters the housing, and are not crimped or damaged.
- 4 When the end cap is fully home, align the screw holes and screw the six socket-head screws into the holes. Tighten the screws using a screwdriver-handled hexagonal key.
- 5 Wipe off any excess grease and clean the unit.
- 6 Perform a final check to ensure all the screws are correctly tightened and nothing has been left out.

The calibration is performed at the HPR / HiPAP system. Refer to *the System operator manual* for the calibration procedure / *APOS on-line help*.

Source level adjustment

For certain applications, you may require to adjust the source level. This is done at the HPR / HiPAP system. For information on how to adjust the source level, refer to the *Standard command reference chapter in the System operator manual* / *APOS on-line help*.

SPT 341/RspSx 110 Vac SU transponder - power module

Drawings of the power modules wiring diagrams:

→ *Refer to page 83.*

As indicated on the drawings:

- The power unit is an AC / DC power unit.
- The 110 Vac input voltage is over-voltage protected.
- The trigger signal is overvoltage protected.
- The output voltage when using the 110 Vac power unit is:
 - * 48 Vdc directly to the transmitter, and
 - * the 48 Vdc is reduced to 10 Vdc in the LM317 controller.
- Tx power output is higher when using the power module (output 48 Vdc) than when using the the back up battery (output 40 Vdc).

MAIN PARTS

General

A transponder consists of the following main parts:

- Transducer
- Housing
- Bottom end cap
- Circuit boards
- Battery pack (described in a separate section)

→ *An example of the transponder's main parts is shown in figure on page 54.*

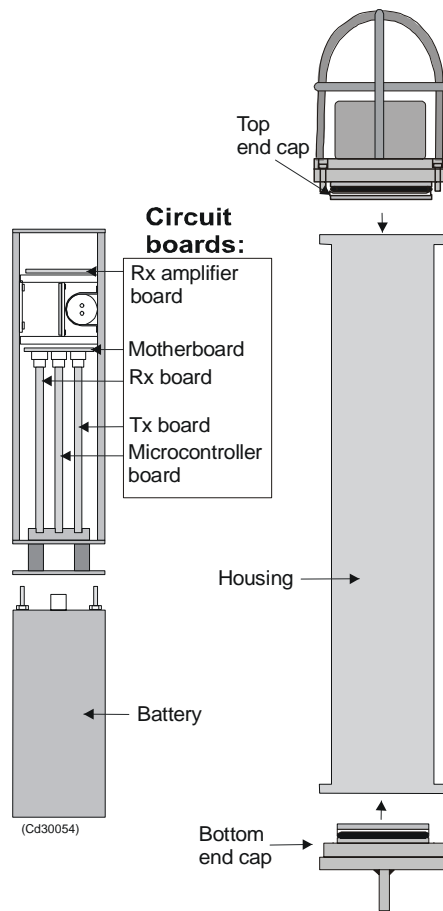

Figure 17 Example of transponder - main parts

Transducer

The transducer is mounted in one end of the cylindrical transponder. The following transducers are used:

- The transducer 30 has a 30° conical beam - MF.

The transducer is connected to the electronics via two wires.

Housing

For information on the housing, refer to *the Technical specification*.

Bottom end cap

A standard bottom end cap includes a shackle.

Circuit boards

The transponder electronics comprises of the following printed circuit boards. These boards are standard for all applications.

- Transmitter board (Tx)
- Receiver board (Rx)
- Rx amplifier board
- Microcontroller board
- Motherboard

Board implemented in the Serial interface unit.

Transmitter board (Tx)

The Transmitter board is a general purpose transmitter, containing its own frequency generator, power control and power supply circuits, (the board feeds both the receiver and microcontroller circuit boards.

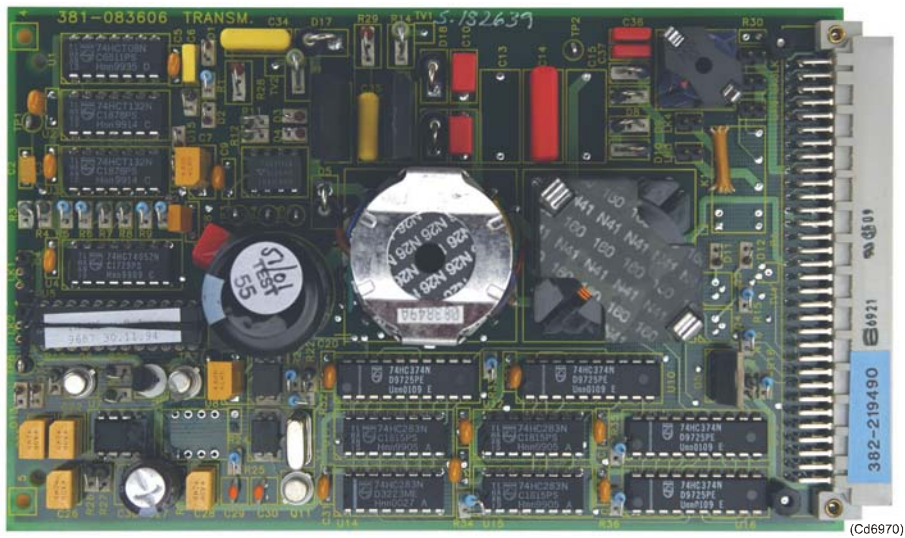

Figure 18 Transmitter circuit board

→ Refer to figure on page 57 for the block diagram.

The board holds two voltage regulators which output the voltages required by the other boards. It also has a crystal oscillator which is used as the Tx frequency source, and a direct numerical synthesizer for generating the correct Tx frequency. Driver stages with power control, an output stage with over-current protection, and transducer matching circuits, complete the board.

Note

*The Relay is only used with the following transponders:
- Dual beam models.*

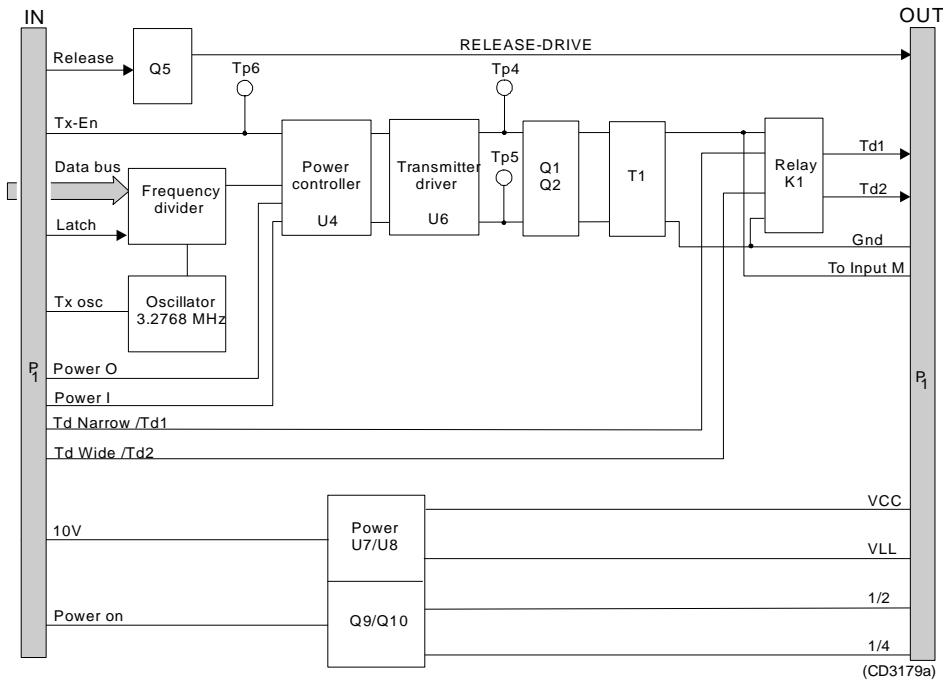

Figure 19 Transmitter circuit board - block diagram

Receiver board (Rx)

The receiver board is designed to receive transponder interrogation signals and telemetry signals. It contains nine narrow-band channel receivers, and a WIDE-detector and phase-locked loops for generating the right modulation frequencies to the channel receivers.

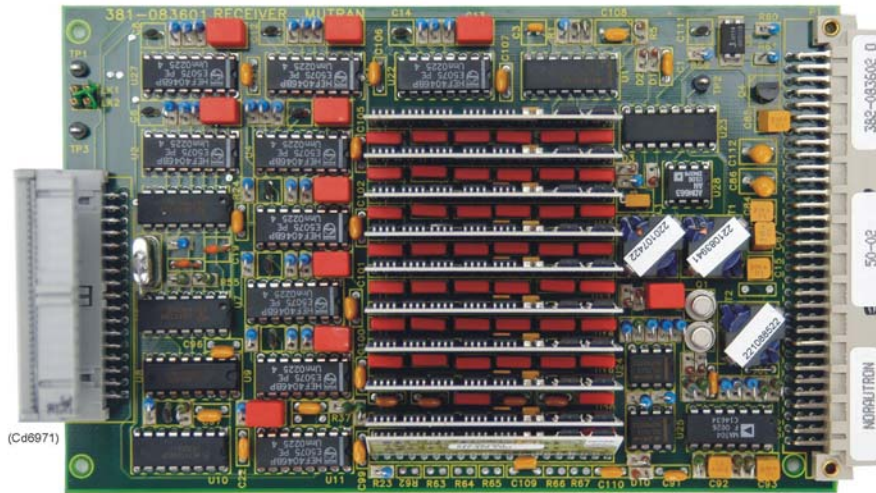

Figure 20 Receiver circuit board

→ *Refer to figure on page 59 for the block diagram.*

The board consists of a two stage amplifier with signal limitation and an anti-aliasing filter, two channel receiver stages for wake-up, and seven channel receiver stages for telemetry, all constructed as ceramic hybrid circuits. The channel receivers perform mixing, low-pass filtering, summing and envelope detection. The outputs from the channel receivers are fed to the microcontroller.

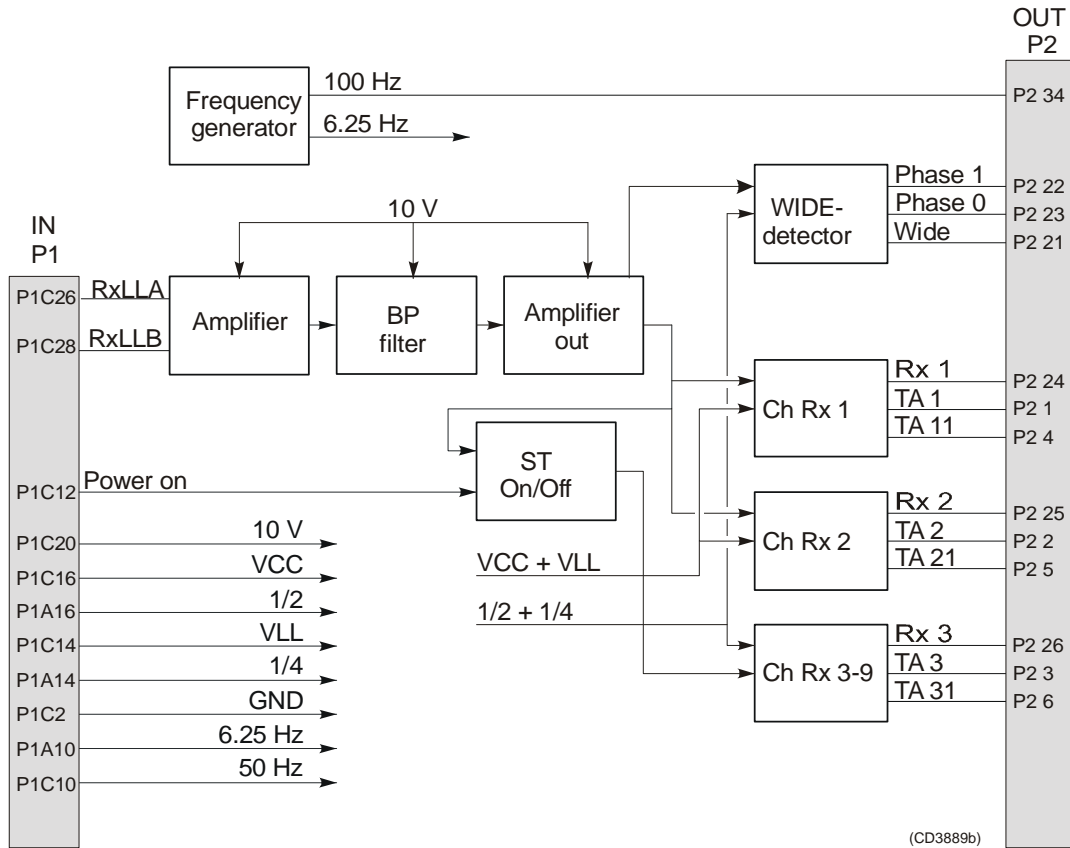

Figure 21 Receiver circuit board - block diagram

Rx amplifier matching board

The TP-PREAMP 24K Hz acts as a matching preamplifier between the transducer and the Channel Receiver circuit board.

→ Refer to figure 22 for the block diagram.

The transducer is connected to TP1 and TP2.

The incoming signal passes through the matching component, T1. From T1, the input signal is connected to a two-step amplifier.

The first step of this amplifier is a low noise FET with a voltage gain of approximately 10 dB.

The signal then enters the micropower operational amplifier, where the gain can be altered in two steps; either 0 dB or 6 dB (approximate values). A logic “0” at TP7 causes 0dB to be achieved. A logic “1” at TP7 causes 6 dB to be achieved.

The amplifier contains a bandpass filter to reduce the input noise before the signal is connected to the output transformer T2. The output to the Rx board is on TP8 and TP9.

TP5 and TP6 are connected to the Transmitter board. When the system is transmitting, a TR-switch in the T1 block protects the input of the amplifier. Transmitted signals are transformed via T1 and leave the board from terminals TP1 and TP2.

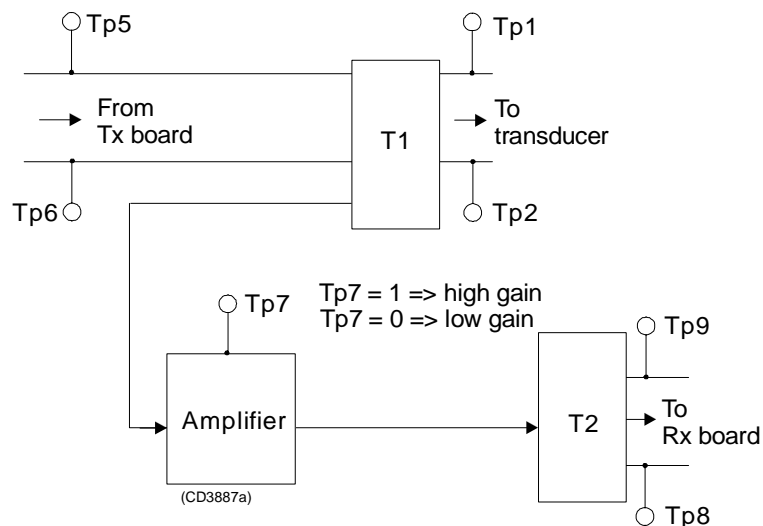

Figure 22 Rx amplifier matching board - block diagram

Microcontroller board

The Microcontroller board is a general purpose single microcontroller board, with the main task of performing calculations and digital signal control. It uses the *87C196KC/KD Microcontroller* manufactured by Intel, and is also equipped with a number of timers, inputs and outputs.

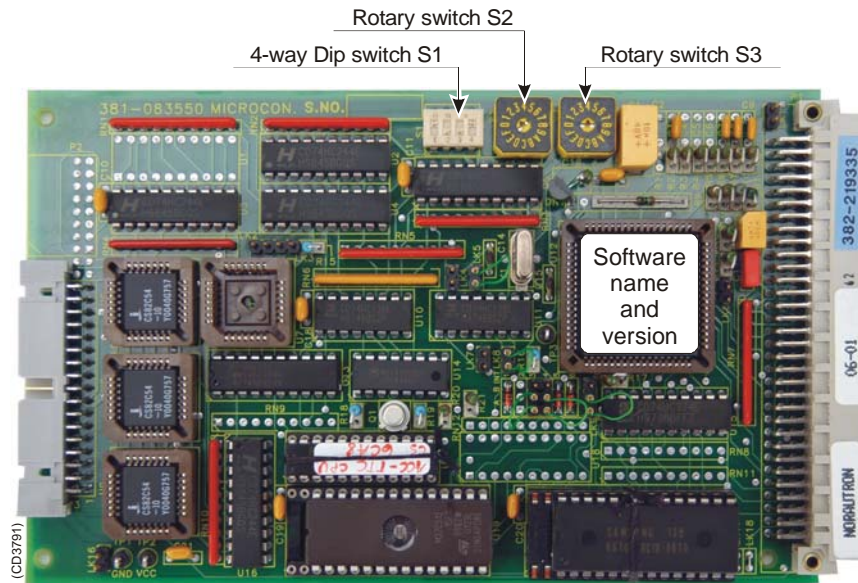

Figure 23 Microcontroller circuit board - switch locations

→ Refer to figure 24 for the block diagram.

The 87C196 microcontroller is the main component on the board. It can be run in different modes such as active, idle and power down, the inactive modes being used to save power. The microcontroller performs all the calculations and controls all the board's inputs and outputs. The timers on the board are used for dividing down the off-board Phase-Locked-Loop frequencies, controlling the receiver frequency channels.

Switches

The board carries one 4-way Dip-switch block and two 10-position rotary switches:

- The Dip-switch block is used to set the system's operating frequency band.

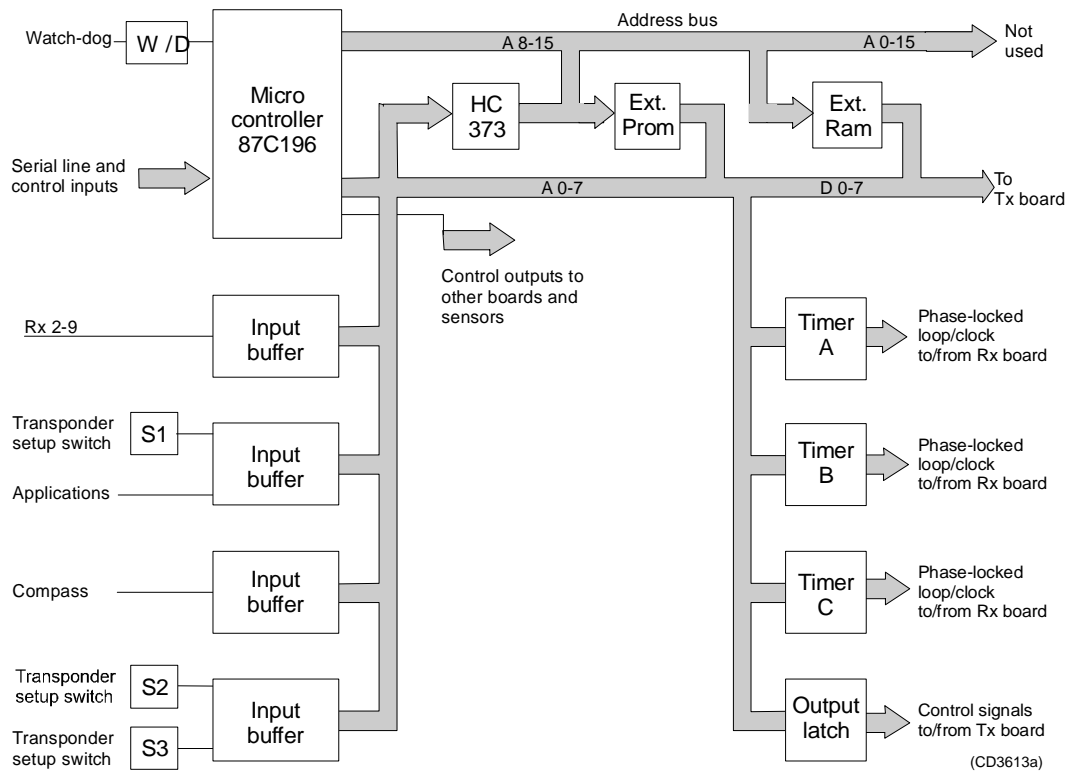

Figure 24 Microcontroller circuit board - block diagram

Motherboard

The motherboard contains all the input/output interfacing for the transponder. It has an interface connection (P4) for the two inclinometers and a + 10 V supply which is turned on only during processing to conserve battery life. It also carries an interface plug (P5) for the Depth/Temp serial line. The TTL interface is buffered through U1 on the motherboard.

Interconnections

The interconnections will differ from tp model to tp model.

Note

For details of the interconnections between the circuit boards, the transducer and the electronics, and the battery and the electronics, contact Kongsberg Maritime.

AUXILIARY EQUIPMENT

General

This section describes various types of auxiliary equipment that may be used to secure a transponder.

Floating rope

A floating rope may be used when collecting the transponder by an ROV.

→ *Refer to example in the figure on page 65.*

Auxiliary equipment supplied by Kongsberg Maritime

Guiding collar

Different types of guiding collars may be used. The most common guiding collar delivered by Kongsberg Maritime comprises of two separate units; an upper and a lower. Each unit is divided into two parts. These parts are placed around the transponder housing and bolted together. It is important that the collar units are mounted correctly.

→ *This is illustrated in the figure on page 65.*

Different types of guiding collars may be used. The most common guiding collar delivered by Kongsberg Maritime comprises of two separate units; an upper and a lower. Each unit is divided into two parts. These parts are placed around the transponder housing and bolted together. It is important that the collar units are mounted correctly.

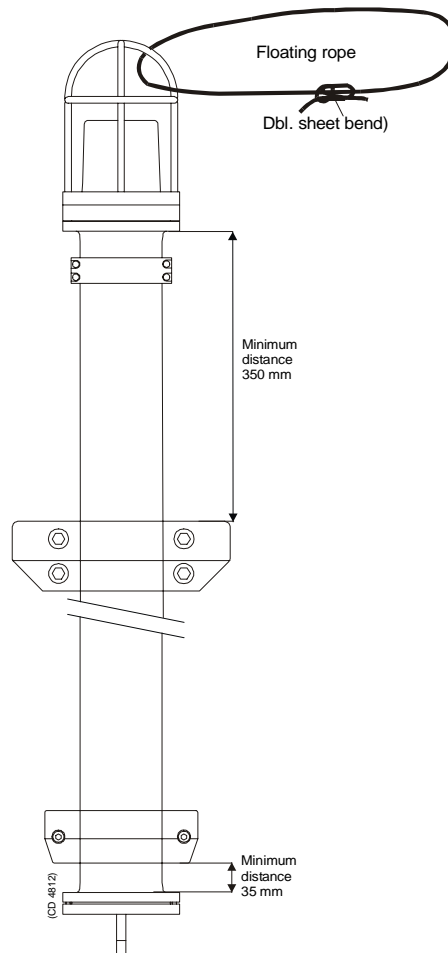

Figure 25 Example of transponder with fitted guiding collar and floating rope

Note

Other types of guiding collars may be supplied on request.

A groove (12 mm wide) is made on the upper guiding collar unit.

Example of use:

The purpose of this groove is to fit the transponder correctly when using a funnel for mounting the transponder. The groove slides over a corresponding guide fin within the funnel. Correct mounting will restrict rotation of the transponder within the funnel. The funnel is equipped with a locking pin to secure the transponder (not supplied by Kongsberg Maritime).

Blank page

SPARE PARTS

Introduction

This chapter lists the parts and modules defined by Kongsberg Maritime as *Line Replaceable Units (LRUs)* for the MPT 341 transponder series. These LRUs are the individual parts and items which the manufacturers considered are replaceable by the local maintenance engineer. Exploded figures are included to assist you with part identification.

Codes used

The following codes are used in the parts lists:

Part no. - Kongsberg Maritime's part number.

Item name - The name of the item.

Technical data - Technical specifications and any other relevant information.

Drw. ref. - Reference number of the production or illustration drawing where the item is included. If a number is given here, the drawing will be included in the manual's/document's drawing file.

Drw. pos. - The item's position number on the drawing referenced above.

No. in sys. - The quantity of the item used in the system. *Note that this information is not provided for standard components such as nuts, bolts and washers.*

Rec. spares - The quantity of the item recommended to be carried as spares onboard the vessel. *Note that this information is not provided for standard components such as nuts, bolts and washers.*

Accessories

This list includes the common accessories used for all transponder types. Since the figure position differs on the figures for these common items, the Drw. pos. is left out.

Part no.	Item name	Drw. ref.	No. in sys.
-	Technical data	Drw. pos.	Rec.spares
540-084173	O-ring	Figures	2
-	124,3 x 5,7	-	2
540-021249	O-ring	Figures	2
-	101,0 x 5,34	-	2
549-086691	Backup ring	Figures	2
-	101,0 x 5,34	-	2
560-085925	Socket-heads screws	Figures	6
-	-	-	6
599-089487	Plug for ID-clamp	Figures	3
-	-	-	-
Depends on model	Information clamp ring	Figures	1
	w/freq.	-	-
Depends on model	Information clamp ring	Figures	1
	w/reg. no.	-	-
380-101422	Flat cable	N/A	-
-	internal	-	-
599-089318	PCB guide	Figures	1/1
599-089320	-	-	-
654-085883	Aquva lube	N/A	-
-	-	-	-
654-077261	Silicone grease	-	1
-	-	N/A	1
659-033481	Loctite	Figures	-
-	Type 242/243	-	1
599-220021	Guiding collar upper	N/A	-
599-220022	Guiding collar lower	-	-
857-164928	SPT and MPT 341 series Instruction Manual	N/A	1
-	(This manual)	-	-

Sensors

Part no.	Item name	Drw. ref.	No. in sys.
-	Technical data	Drw. pos.	Rec.spares
339-211580	Inclinometer- sensor	N/A	-
-	-	N/A	-

Batteries

Note

The Lithium battery is specified for each transponder.

Part no.	Item name	Drw. ref.	No. in sys.
-	Technical data	Drw. pos.	Rec.spares
290-216804	Alkaline battery	N/A	-
-	A10/36 (24/24)	N/A	-
290-212364	Rechargeable battery	N/A	-
-	N10/36 (18/30)	N/A	-

SPT 341/I transponder

Complete transponder

Part no.	Item name	Drw. ref.	No. in sys.
-	Technical data	Drw. pos.	Rec.spares
102-220148	SPT 341/I Transponder complete	Figure page 71	1
-	All main modules are included	N/A	-

Main modules

This list includes the main modules for the SPT 341/I transponder.

Part no.	Item name	Drw. ref.	No. in sys.
-	Technical data	Drw. pos.	Rec.spares
312-214878	SPT 341 Transducer	Figure page 71	1
-	-	1	-
299-103147	Electronic chassis	Figure page 71	1
-	Motherboard, Rxamp board and sensors (if used) are included (1)	27	-
382-102852	Tx board	Figure page 71	1
-	-	2	-
382-083551	Microcontroller board	Figure page 71	1
-	-	3	-
382-102853	Rx board	Figure page 71	1
-	-	4	-
290-103053	Battery pack	Figure page 71	1
-	-	9	-
599-213028	Housing	Figure page 71	1
-	-	14	-
499-215049	Bottom end cap	Figure page 71	1
-	-	26	-

Accessories

→ Refer to page 68.

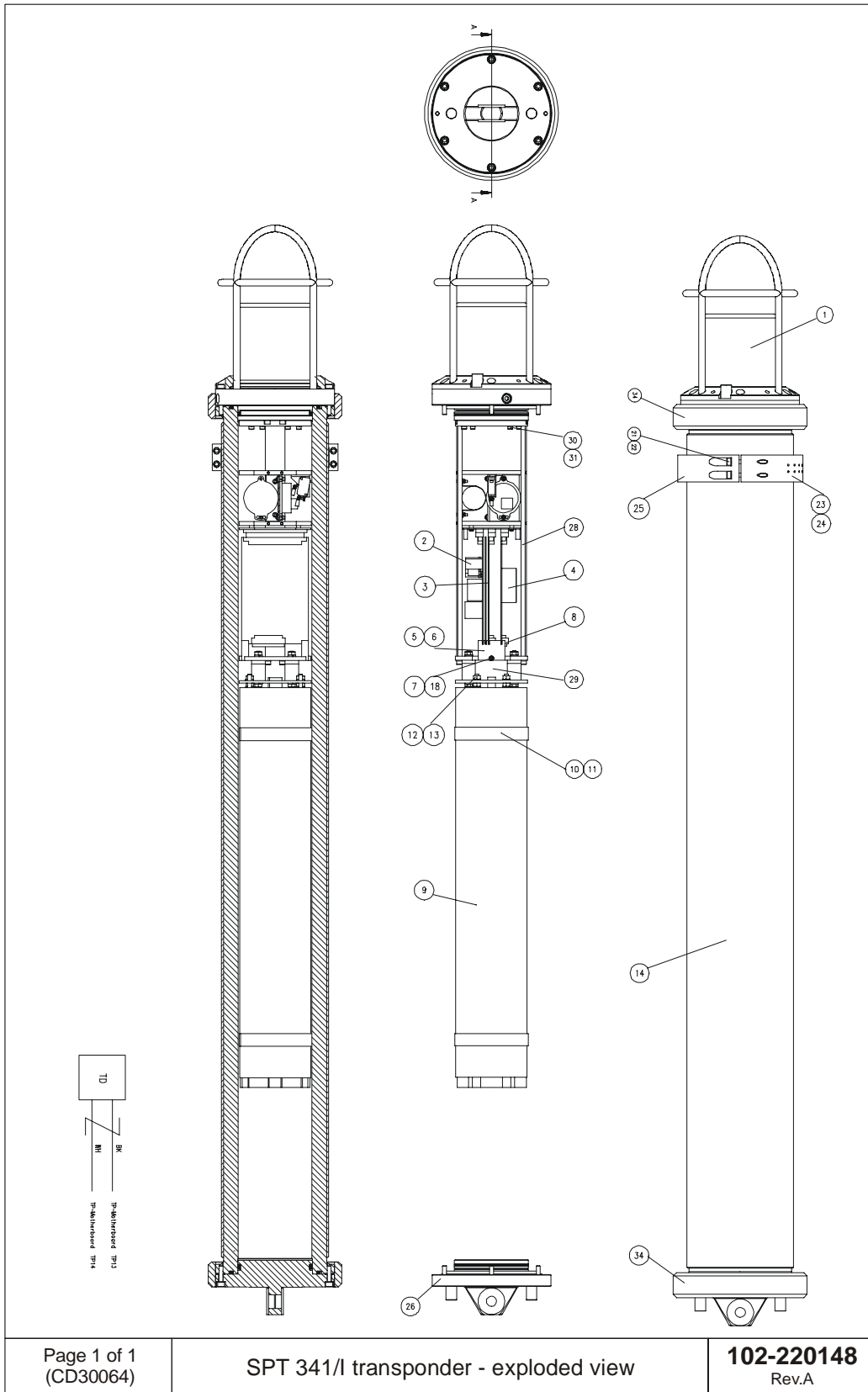

SPT 341/RspSx 110 Vac SU transponder

Complete transponder

Part no.	Item name	Drw. ref.	No. in sys.
-	Technical data	Drw. pos.	Rec.spares
102-220893	SPT 341/RspSx 110 Vac SU Transponder complete	Figure page 73	1
-	All main modules are included	N/A	-

Main modules

This list includes the main modules for the SPT 341/I transponder.

Part no.	Item name	Drw. ref.	No. in sys.
-	Technical data	Drw. pos.	Rec.spares
100-220894	SPT 341/RspSx 110 Vac SU transducer unit	Figure page 74	1
-		30	-
299-211002	Electronic chassis (short)	Figure page 73	1
-	Motherboard, Rxamp board and sensors (if used) are included (1)	30	-
382-102852	Tx board	Figure page 73	1
-	-	2	-
382-083551	Microcontroller board	Figure page 73	1
-	-	3	-
382-102853	Rx board	Figure page 73	1
-	-	4	-
107-103000	Power module	Figure page 73	1
-	Backup battery is included (1)	9	-
198-085263	Zinc anode	Figure page 73	1
-	207-5000 Iss1	34	-
370-086715	UV-receptacle	Figure page 73	1
-	10.00.1.04.2.10 4p	37	-
370-086715	Protection cap	Figure page 73	1
-	10.20.1.00.01	39	-

1 Separate Backup battery, part no: 290-102726

Accessories

→ *Refer to page 68.*

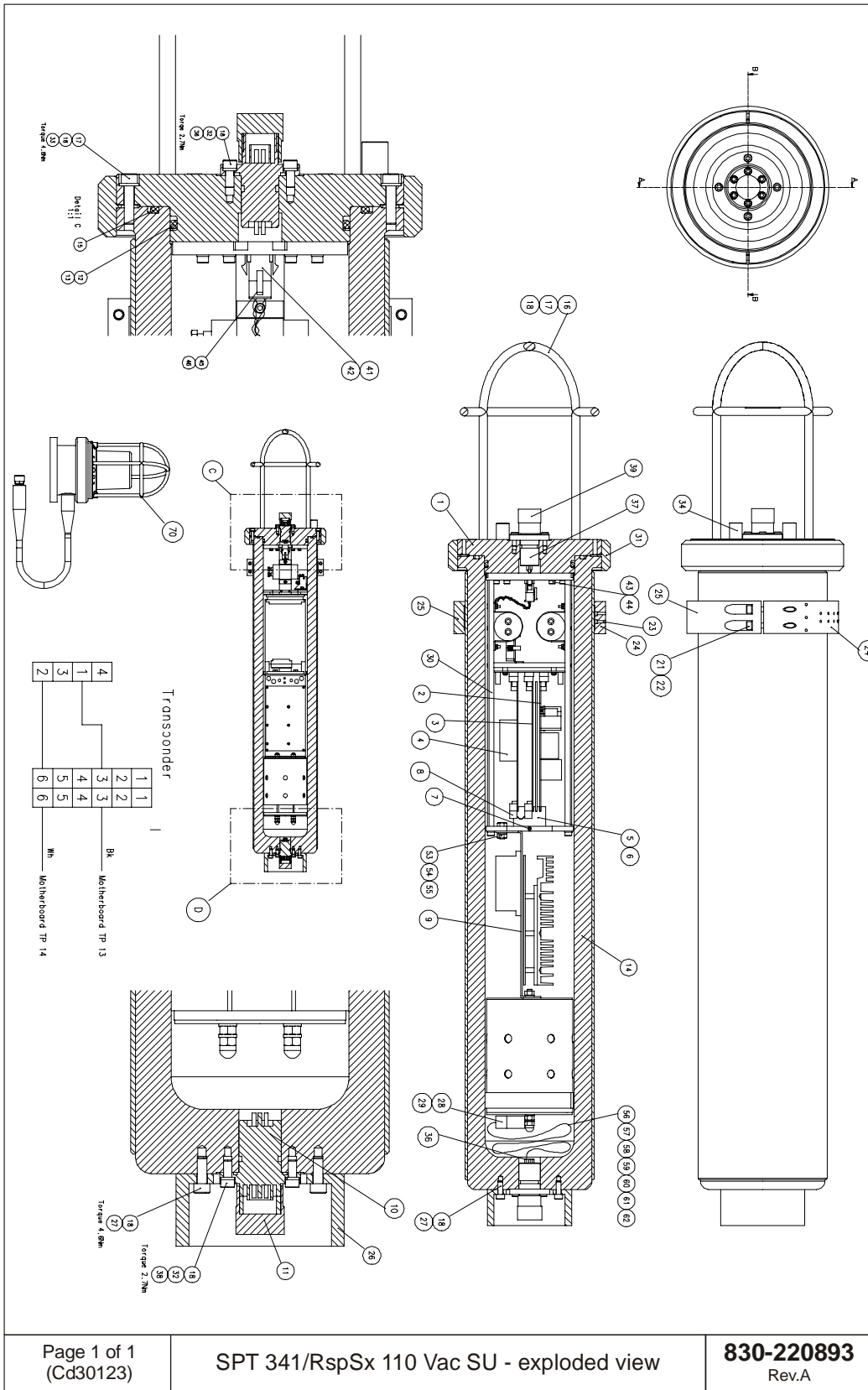

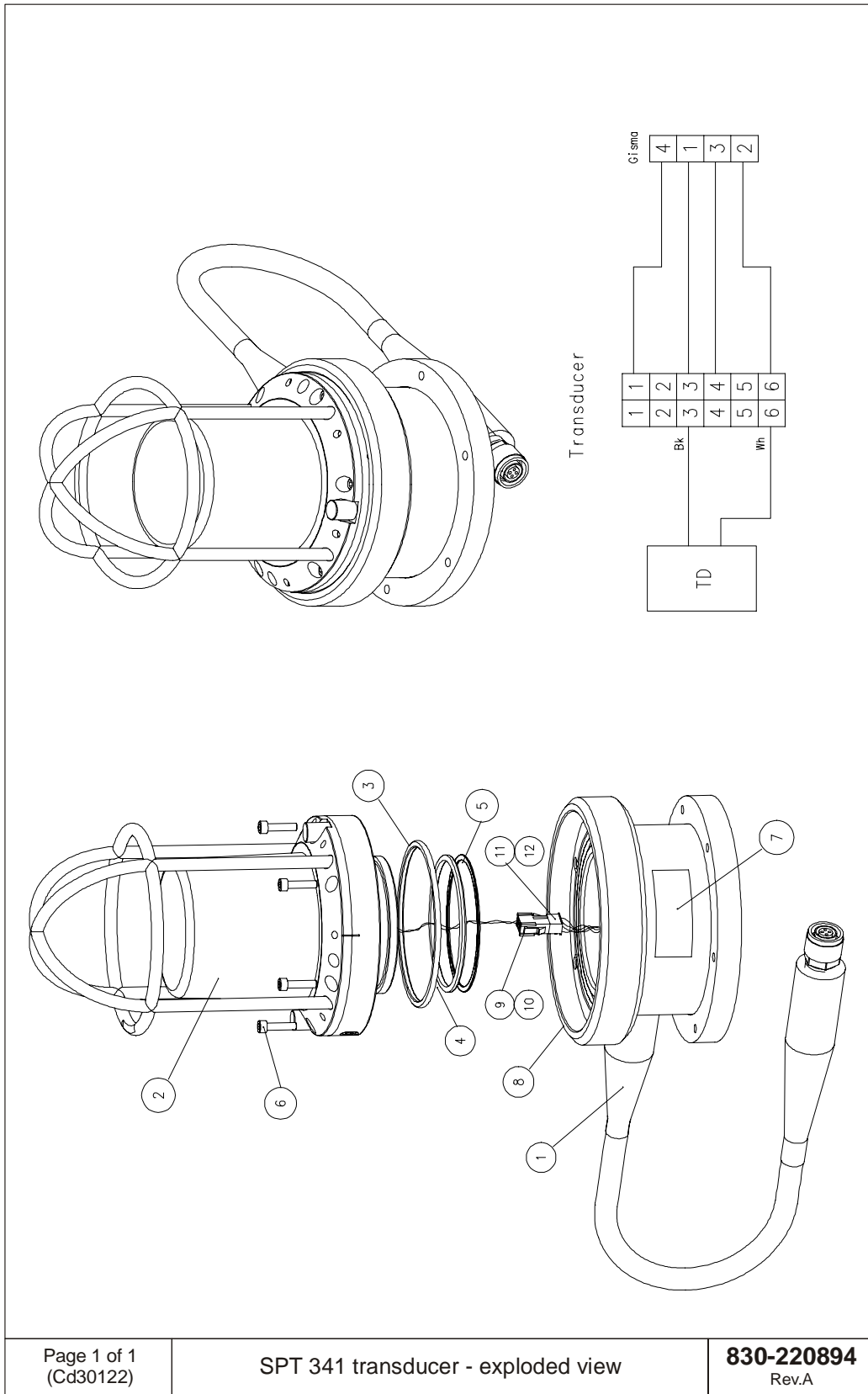

Blank page

MPT 341/DuB transponder

Complete transponder

Part no.	Item name	Drw. ref.	No. in sys.
-	Technical data	Drw. pos.	Rec.spares
102-217861	MPT 341/DuB Transponder complete	Figure page 77	1
-	All main modules are included	N/A	-

Main modules

This list includes the main modules for the MPT 341/DuB aluminium transponder.

Part no.	Item name	Drw. ref.	No. in sys.
-	Technical data	Drw. pos.	Rec.spares
312-214880	MPT 341/DuB Transducer	Figure page 77	1
-	-	1	-
299-210414	Electronic chassis	Figure page 77	1
-	Motherboard, Rxamp board and sensors (1) (if used) are included	28	-
382-210413	Tx board	Figure page 77	1
-	-	2	-
382-083551	Microcontroller board	Figure page 77	1
-	-	3	-
382-211016	Rx board	Figure page 77	1
-	-	4	-
290-103053	Battery pack	Figure page 77	1
-	-	9	-
599-213028	Housing	Figure page 77	1
-	-	14	-
499-215049	Bottom end cap	Figure page 77	1
-	-	26	-

Accessories

→ *Refer to page 68.*

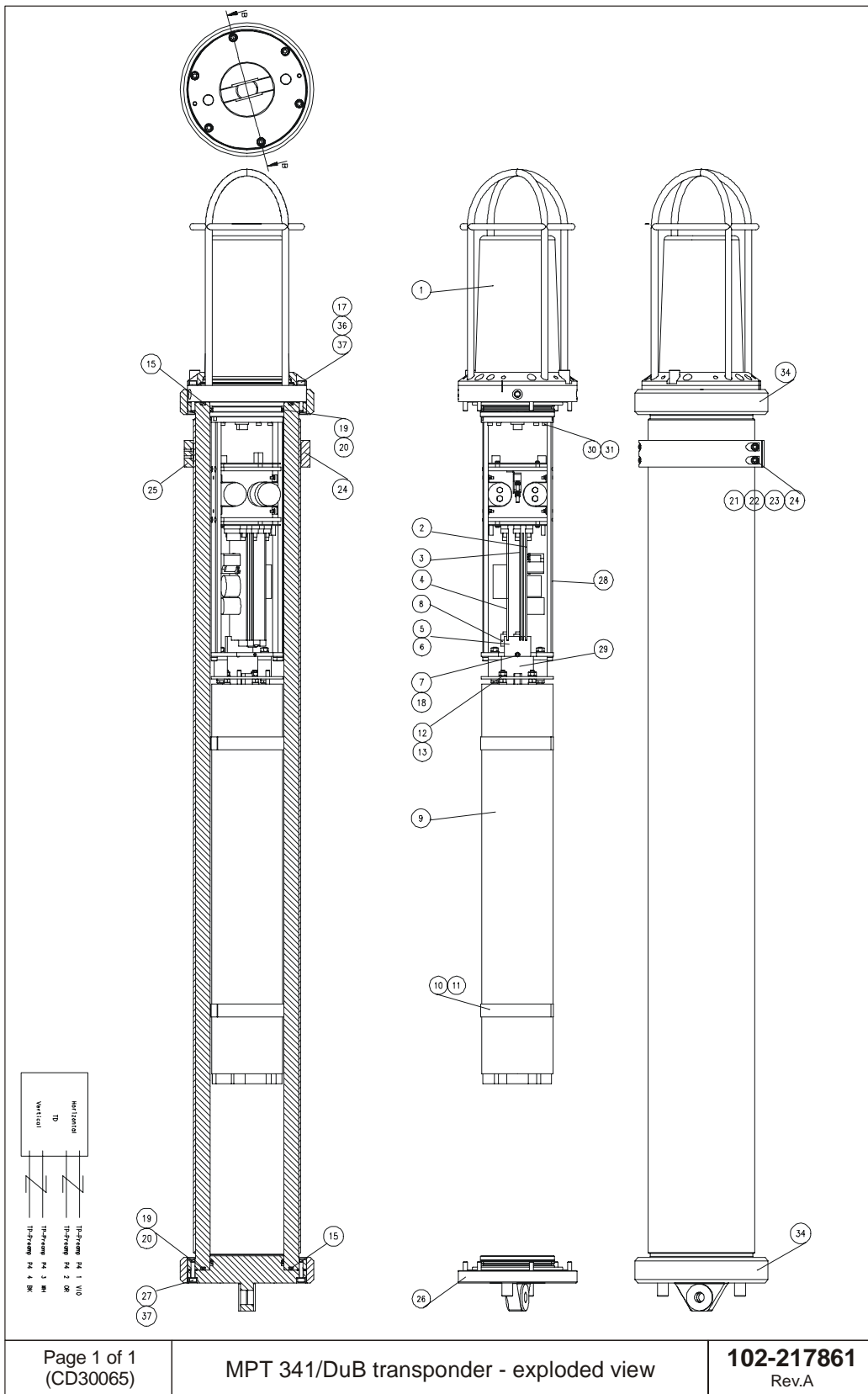

DRAWING FILE

Overview

This section contains outline dimension drawings. These are based on the original system drawings.

- All measurements are in mm.
- The illustrations are not in scale.
- The original drawings are available in electronic format (AutoCAD) upon request.

Drawings

The following drawings are included:

Outline dimensions

- SPT 341/I, page 79
- SPT 341/RspSx 110 Vac SU, page 80
- SPT 341 split transducer, page 81
- MPT 341/DuB, page 82
- Guiding collar, page 84

Wiring diagram

- Power module, SPT 341/RspSx 110 Vac SU, page 83.

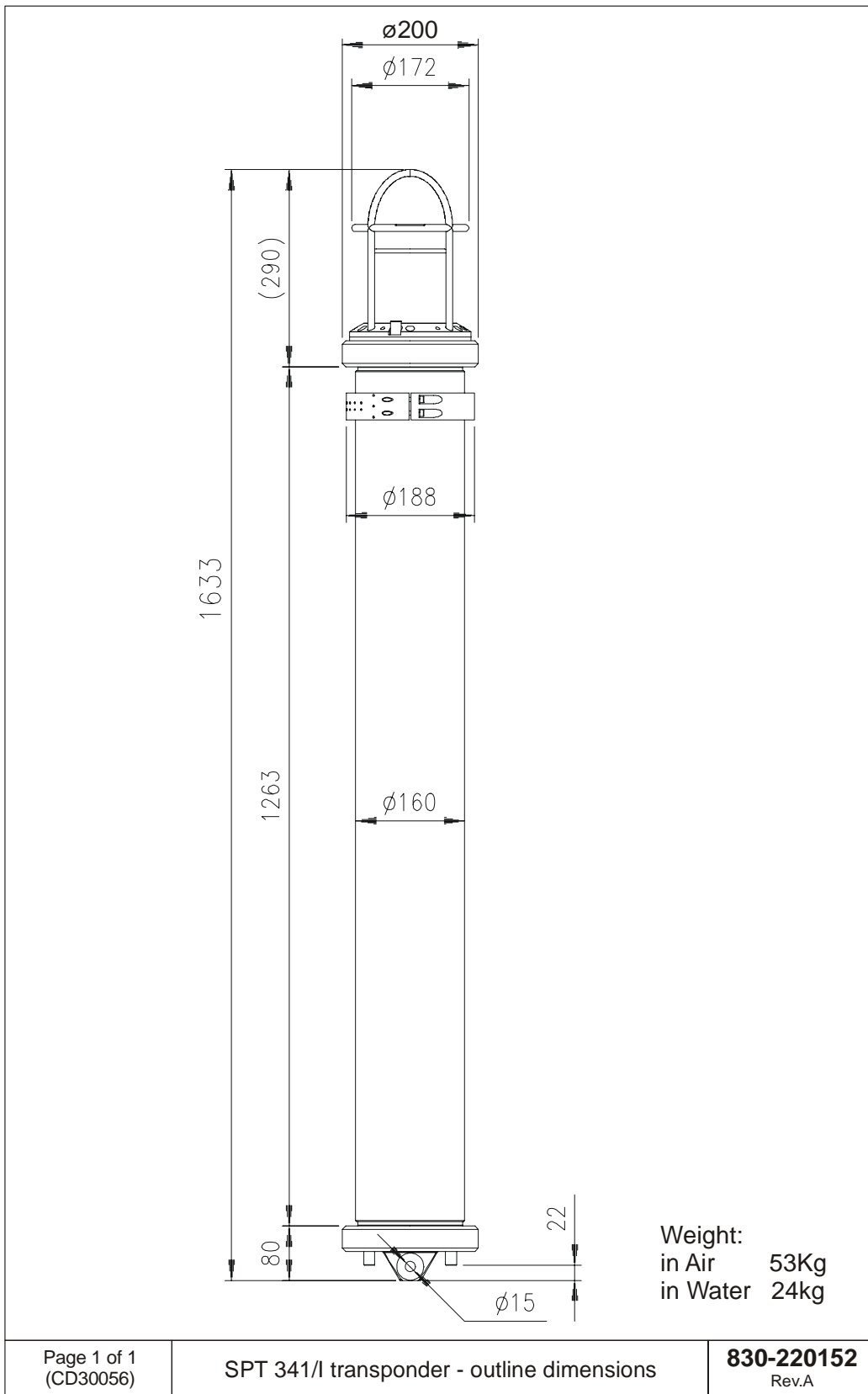

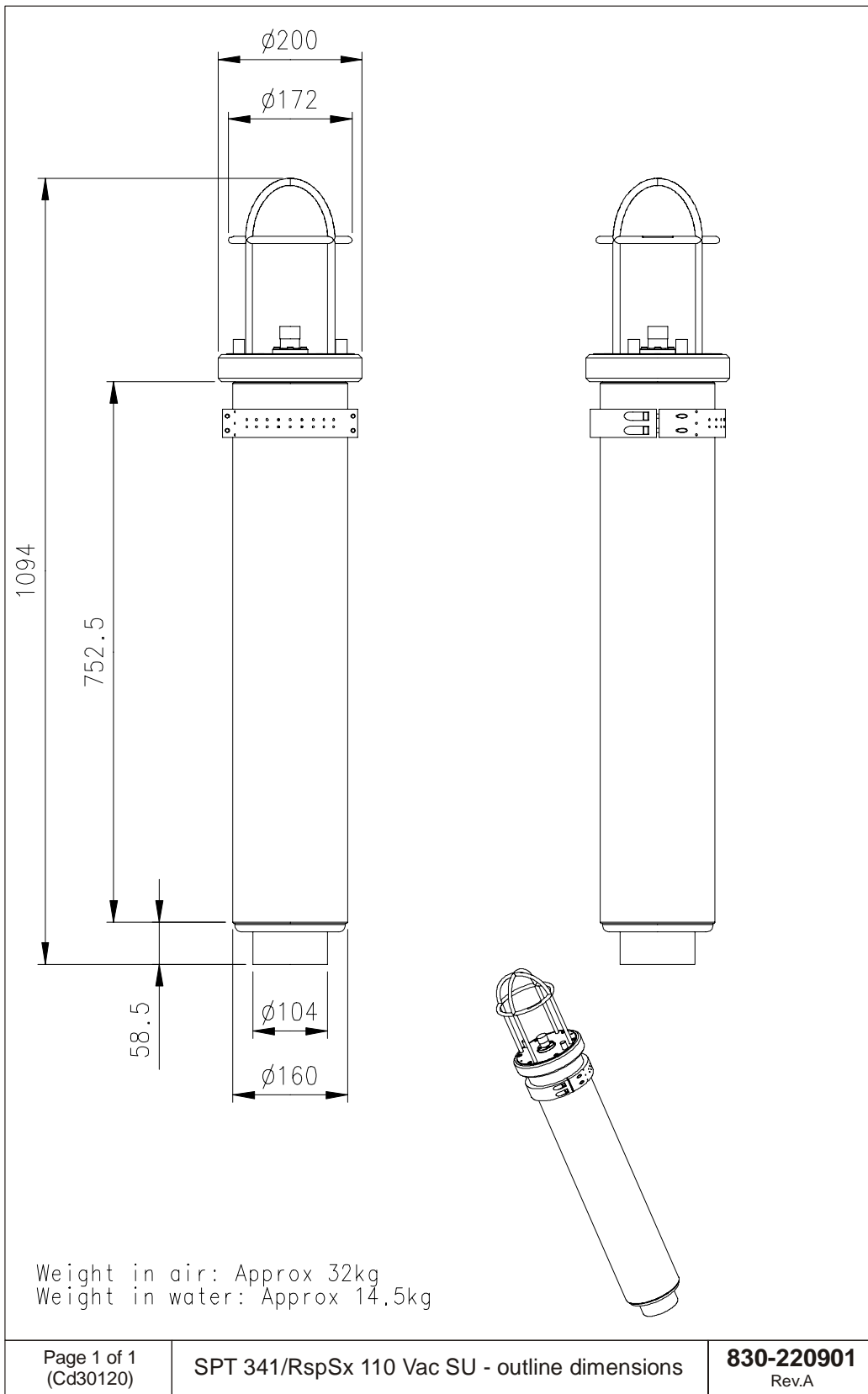

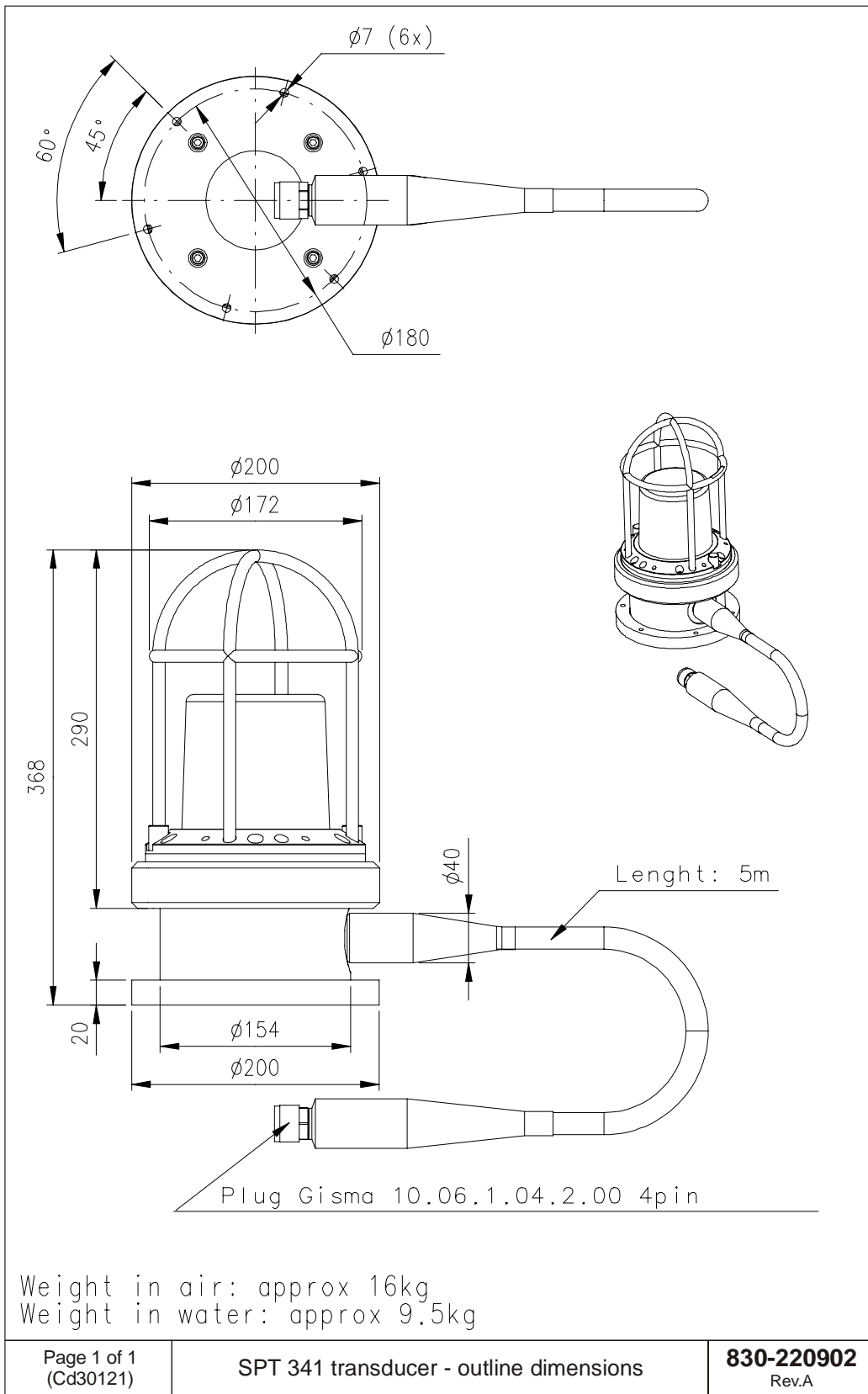

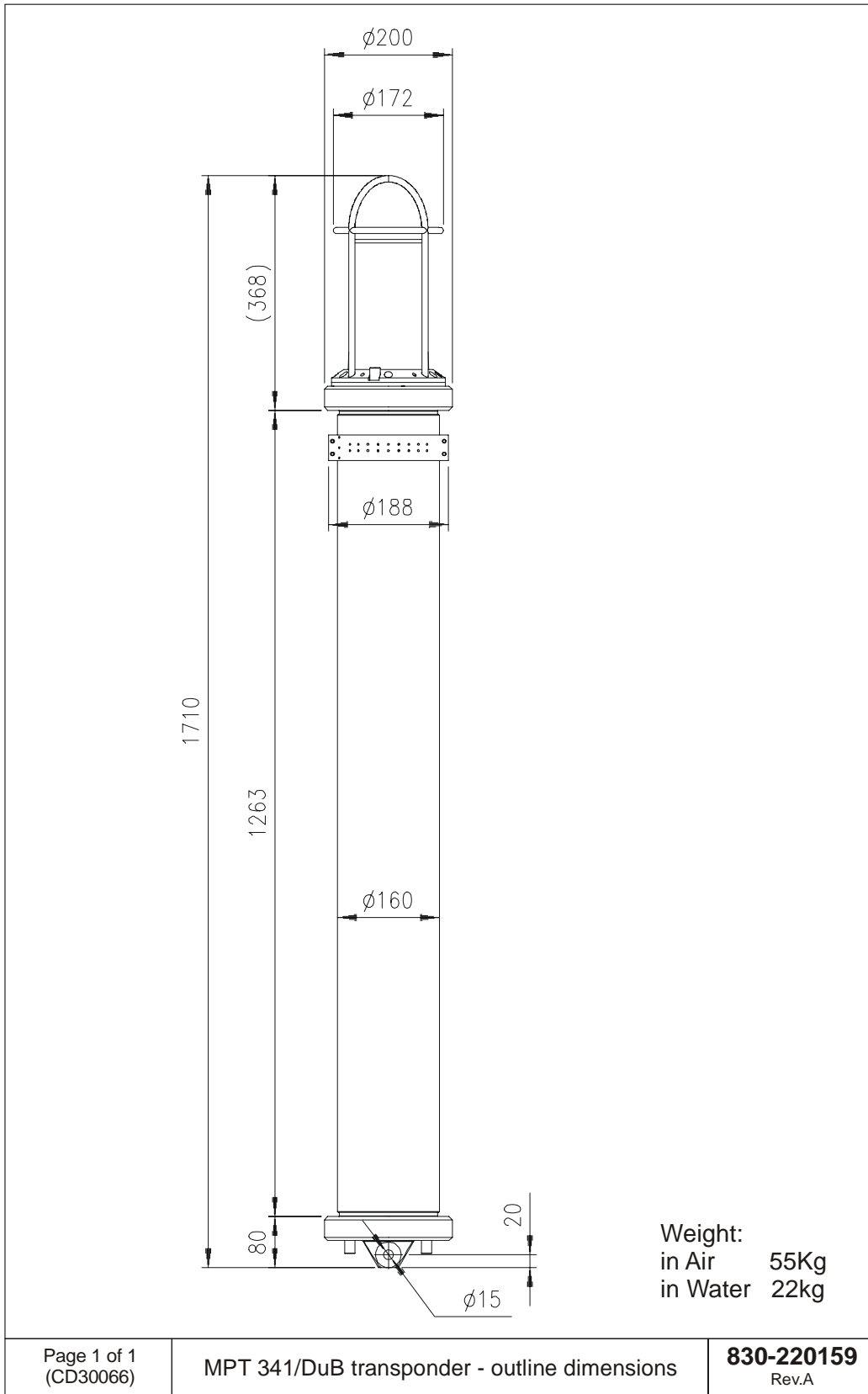

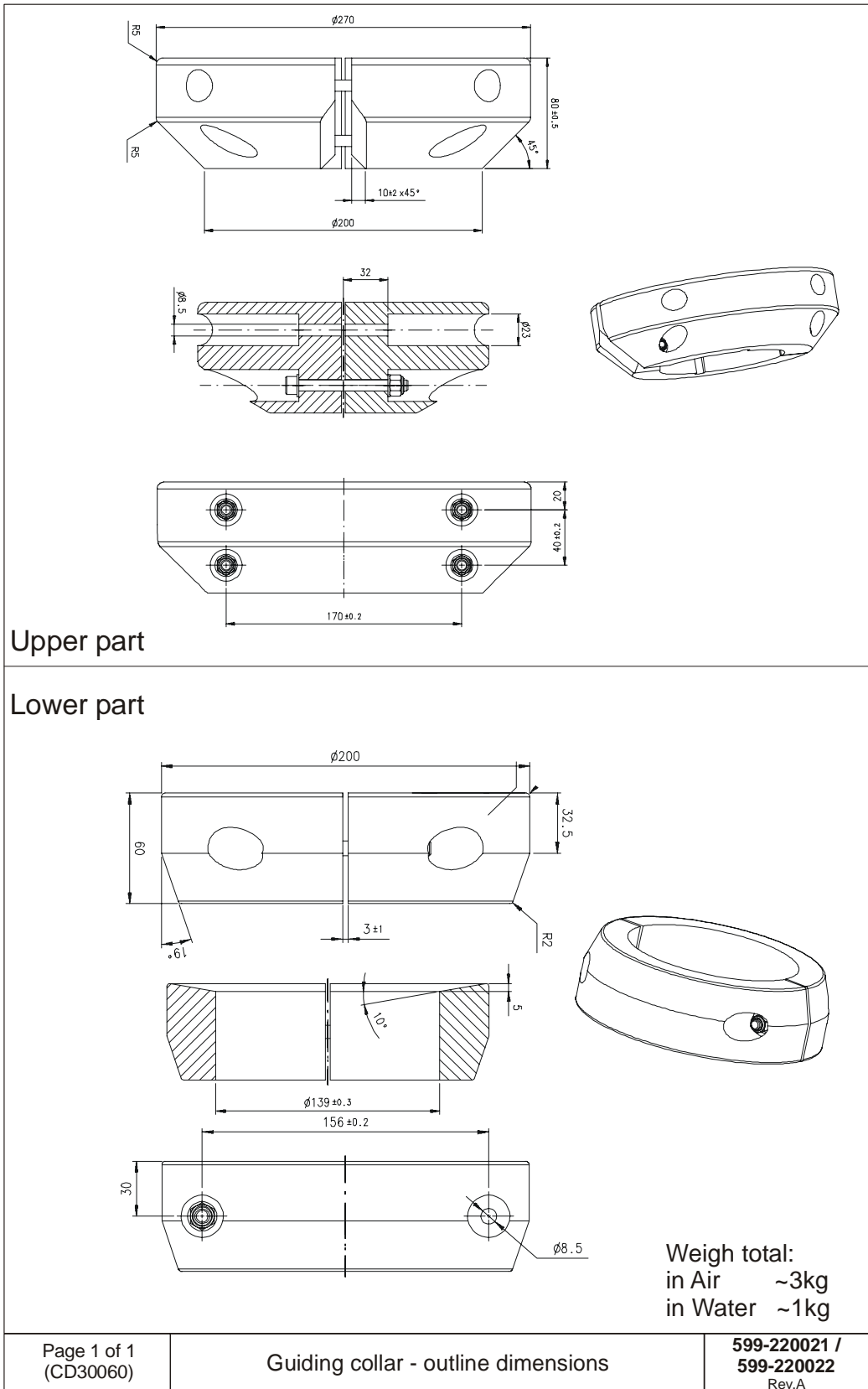

INDEX

The next pages presents the index of this manual.

A

Abbreviations, 2
AC/DC power unit, 52
Accessories, 68
 Technical data, 68, 69
Acoustic coding, 41
Acoustic telemetry, 39
Alkaline battery pack, 34
Alkaline battery storage, 35
APOS, 26
APOS Instruction manual, 26
APOS on–line help, 27
Applications, 4
 MPT specific, 4
 SPT specific, 4
Assembling, 51
 Before you start, 51
Auxiliary equipment, 64
Available channels, 42
Available transponders, 5

B

Basic model, MPT 341, 8
Basic models, 8
Batteries, 69
Battery
 Receiver part (Rx), 15
 Transmitter part (Tx), 15
Battery capacity, 30
Battery cell manufacturers, 16
Battery cell types, 16
Battery chemistry, 15
Battery design, 15
Battery lifetime at operation, 31
Battery lifetime at quiescent state, 34, 36
Battery pack, 53
 Max continuous on time, 34
 Quiescent lifetime, 34
Battery packs
 Max continuous on time, 33

 Quiescent lifetime, 33
Battery replacement, 30
Battery shelf lifetime, 33, 35
Battery storage, 33
Beacon mode, 27
Beam patterns, 10
Before you open the unit, 45
Bottom end cap, 53, 54

C

CCF, 43
Channel setting, 25
Channels, 43
Circuit boards, 53, 55
Clamp ring, 3
Common Command Frequency, 43, 44
Common specifications, 11
Configuration, 39
Connecting the battery, 25
Connecting the transponder battery, 37
Contents, 1
Cylinder body, 45

D

Danger of explosions, 16
Defect battery, 21
Deployment, 27
Depth measurement, 4
DIL switches, 40
Dismantling the transponder, 45
Disposal considerations, 23
DRAWING FILE, 78
Drawings, 78

E

Ecological information, 22
End cap, 50
External connector, 13
 RspSx 110 Vac SU, 13

External power, 44

F

Factorial coding, 41
 Fire–fighting measures, 18
 First–aid measures, 18
 Floating rope, 64
 Frequency bands, 39
 Frequency shift keying, 43

G

Guiding collar, 64
 Example of use, 65
 Guiding collars, 12

H

Handling a heated or self–heated transponder, 20
 Handling a transponder if the relief valve opens, 20
 Handling heated or self–heated free–standing battery, 21
 Hazards identification, 16
 High pressure hose, 28
 HiPAP, 2, 25, 39
 HiPAP channels, 40
 HiPAP compatibility, 4
 HiPAP system, 40, 41
 Housing, 45, 53, 54
 Housing material, 5, 7
 HPR, 2, 25
 HPR 300 channels, 43
 HPR 300 command function, 43
 HPR 300 frequencies, 43
 HPR 300 series, 39
 HPR 300 switch settings, 43, 44
 HPR 400 channels, 40, 42
 HPR 400 series, 39

HPR compability, 4

I

Identification, 3
 Identification clamp ring, 4
 IFF, 43
 Illustrations:
 A 4 pin and a 7 pin external connector – layout, 13
 Battery connector and mounting screws, 38
 Battery lifetime at operation, 32, 34, 36
 Battery lifetime at quiescent state, 33
 Connecting the battery, 37
 Example of beam pattern, 10
 Example of transponder – main parts, 54
 Examples of SPT and MPT 341 series transponders, 3
 Microcontroller board (CPU), 62
 Microcontroller board – switch settings, 40
 Microcontroller circuit board – switch locations, 61
 Receiver board (Rx), 58
 Receiver board (Rx) – block diagram, 59
 Rx amplifier matching board – block diagram, 60
 SPT 341 pressure housing assembly, 47
 Top view of the inclinometer transponder – showing the front direction, 28
 Transducer head, indicating the two sealing screws, 49
 Transmitter circuit board, 56
 Transmitter circuit board – block diagram, 57
 Transponder reception and transmission signal timing diagram, 42
 Transponder with fitted guiding collar, 65
 Transponder with floating rope, 65
 Inclination measurement, 4
 Inclinometer sensors, 27
 Individual Interrogation Frequency, 43
 Input voltage, 110 Vac, 52
 Interconnections, 63
 Internal switches, 39

L

LBL, 2

LBL positioning, 4
 Line Replaceable Units, 67
 Lithium Battery, 1
 Lithium battery packs, 31
 Lithium Thionyl Chloride, 15
 Locking pin, 65
 LRUs, 67

M

Main parts, 53
 MAINTENANCE, 45
 Maximum detectable angles, 11
 MF, 2
 Microcontroller board, 55, 61
 Microcontroller board (CPU), Purpose, 61
 Model, 5
 Model name, 6
 Model number, 6
 Models
 DuB, 8
 I, 8
 RspSx 110 Vac, 8
 RspSx 110 Vac SU, 8
 Motherboard, 55, 63
 Mounting, 26
 MPT, I, 2, 6
 MPT, 5
 MPT 341/DuB, 11
 MPT 341/DuB transponder, 76
 Technical data, 76

N

Name principles, Example, 7
 Noxious gases, 17

O

O-ring, 45, 46, 50, 51, 68
 On-line help, 26

Opening the pressure housing, 45
 Opening a 'functioning' transponder, 21
 Opening a transponder, 21
 Opening the unit, 45
 Operating frequencies, 42, 43
 Operation, 25, 27
 Options (names), 6
 Output – Power module, 10 Vdc, 52
 Outline dimensions, 78
 Output – Power module, 48 Vdc, 52
 Overview, 78
 Overvoltage, 52

P

Personals protection, 19
 Positioning frequencies, 42
 Positioning of a transponder, 27
 Power module, 52
 Power unit – 110 Vac, 52
 Pre-deployment checks, 26
 Pressure housing assembly, 45
 Product identification, 15
 Pulse position coding, 43

R

Range measuring, 4
 Receive sensibility, 10
 Receiver board, 58
 Receiver board (Rx), 55
 Purpose, 58
 Receiver sensitivity, 11
 Rechargeable battery pack, 36
 Recovering a 'failing' transponder, 19
 Recovering a 'functioning' transponder, 19
 Recovery, 28
 Related manuals, APOS Instruction manual, 25
 Release mechanism, 46
 Release unit, 50

Remove the bottom end cap, 50

Replacement

- Microcontroller board, 47
- Motherboard, 48
- Rx board, 47
- Rx–amplifier matching board, 48

Replacement of the batter, 50

Replacement of the battery, 28

Replacement of the transponder battery, 38

Reset, 38

Resolution, 11

Responder, 44

Responder connector, 46

Responder function, 28

Responder trigger connector, 46

Rotary switches, 40

ROV, 2, 64

RspSx 110 Vac SU, 12

Rx, 58

Rx amplifier board, 55

Rx frequencies, 42

S

Safety information, 25

Screwed flange, 45

Sealing screws, 49

Sealing surfaces, 46

Self positioning, 4

sensitivity, 10

Sensors, 69

Serial interface unit, 55

Silica–gel, 51

Silica–gel bag, 38

Socket–head screws, 50

Socket–head screws, 50

Source level, 11, 51

Source level adjustment, 51

Spare parts, 67

Split housing and transducer, 12

SPT, I, 2, 6

SPT 341, 5

SPT 341, 8

SPT 341/I, 11, 32

SPT 341/I□□MPT 341/DuB, 32

SPT 341/I transponder, 70

- Technical data, 70, 72

SPT 341/RspSx 110 Vac SU, 32

SPT 341/RspSx 110 Vac SU transponder, 72

SPT 431/RspSx 110 Vac SU transponder–
power module, 52

SSBL, 2

SSBL positioning, 4

Storage, 22, 28

Switch settings, 40

System set–up, 25

T

Tables

- HPR 300 frequencies and switch settings, 44
- HPR 300 switch settings, 44
- HPR 400 switch settings, 43
- RspSx 110 Vac SU base external connector, 14
- RspSx 110 Vac SU top external connector, 13

TECHNICAL SPECIFICATIONS, 11

Technical specifications, RspSx 110 Vac, 12

Telemetry frequencies, 42

Telemetry link, 41

Telemetry of sensor data, 4

TP, 2

Transducer, 27, 53, 54

Transducer cage, 45

Transducer head, 45

Transmit, 10

Transmitter board, 56

Transmitter board (Tx), 55

Transponder assembly, 51

Transponder channes, 39

Transponder configuration, General, 39

Transponder design, 2
Transponder in use, 26
Transponder model identification principles, 6
Transponder models description, 8
Transponder safety information, 15
Transponder series, 5
Transponder Test and Configuration Unit, 26
Transport information, 24
Trigger pulse, 28
TTC 400, 26
TTC 400 Instruction manual , 26
TTC 400 Quick Reference Guide, 26
Tx, 56
Tx board, 47
Tx frequencies, 42

W

Wires, 46
Wiring diagram, 78