

# UNDERWATER MOUNTABLE THRUSTERS

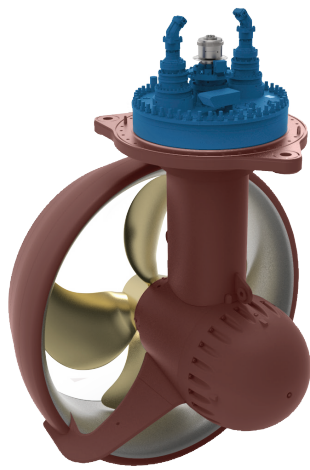

KONGSBERG

## KONGSBERG AZIMUTH THRUSTERS

### Underwater mountable thrusters, type UUC

#### General

The basic unit for offshore thruster applications is a compact unit and includes:

- L-drive with integrated steering gear
- Nozzle Straight or tilted with mild or stainless steel inner surface
- FP propeller for variable speed
- Electricdrive
- Hydraulic steering gear

Design is suitable for various applications and gives advantages for maintenance.

#### UUC

Design for underwater mounting and dismounting.

#### USE

Designed for installation in dry conditions. Can be mounted directly to the hull or on a container.

#### USL

Compact design with bottom well and foundation for vertical drive motor. USL-installation method means wet mounting from the top through a casing.

#### TYPICAL APPLICATIONS

- Semi-sub drilling rig/ships
- Production vessels
- Other large vessels
- Offshore windmill installation vessels

#### TECHNICAL DATA

UUC size	305	355	405	455	505
Prop. diameter (m)	3.0 - 3.2	3.5 - 3.5	3.8 - 3.8	4.1 - 4.1	4.5
Power (kW)	3000 - 3200	3800 - 4000	4500 - 4800	5000 - 5500	6500
Input (rpm)	720 - 720	720 - 750	720 - 750	720 - 750	600
Thrust (mtons)	55 - 61	71 - 74	84 - 90	95 - 102	123
UUC HT size	305	355	405	455	
Prop. diameter (m)	4.1	4.5	5	5.5	
Power (kW)	3200	3800	4500	5500	
Input (rpm)	720	750	720	600	
Thrust (mtons)	72	86	102	127	

The final data is subject to application and to be reconfirmed by KONGSBERG

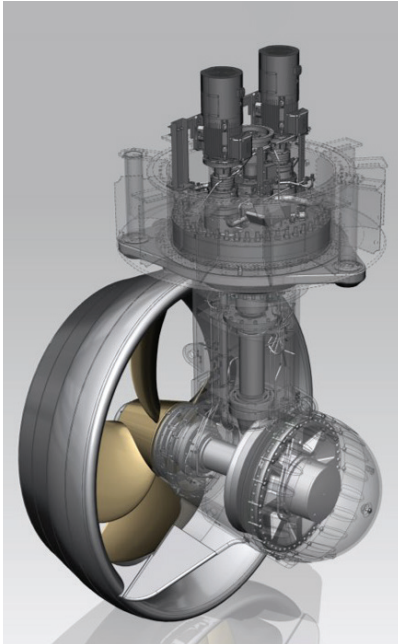

## UUC HT High Thrust

With the new UUC HT we are introducing new High Thrust members in the well known and trusted product range, strengthening it still. All of the components are within our well proven range, and the HT product range is interchangeable with existing UUC series:

405 → 355 HT

455 → 405 HT

Larger slowly rotating propeller creates same thrust with less power giving increased efficiency up to 18 – 25 %

Smaller e-motor and drive also provides:

- Less installed power on Vessel (number of engines / size of engines)
- Reduced underwater noise

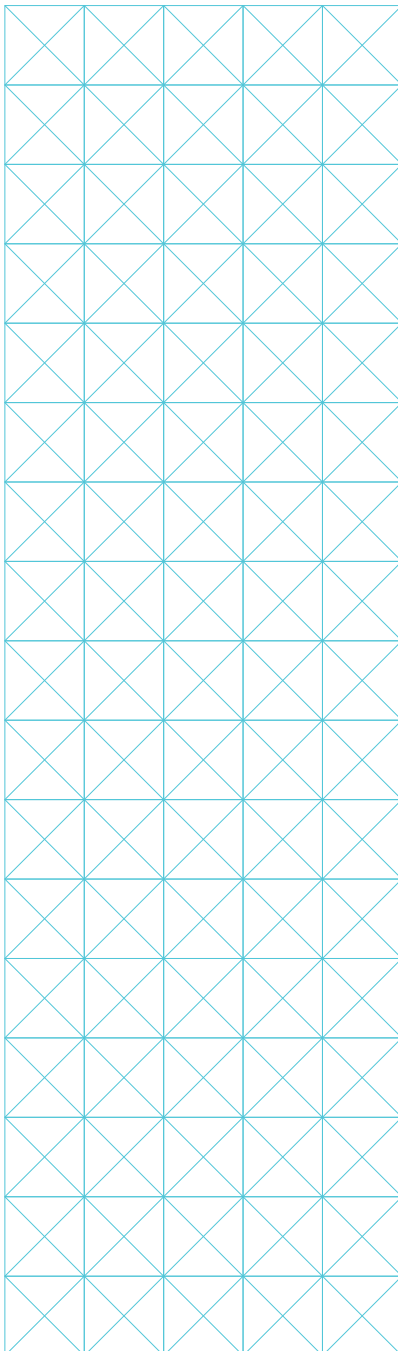

## Features available for the UUC family

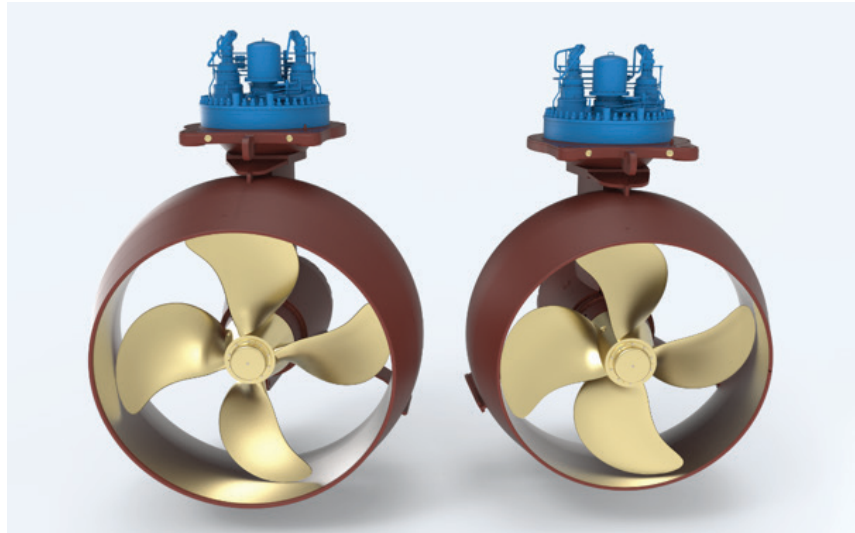

- Fully electrical steering 2x50% (hydraulic 1x100% or 2x100%)
- Silent Hydraulic Power Packs with noise isolation (<85dB)
- Condition Monitoring systems with Customer Portal
- Improved wire connection system for diverless installation
- Reduced height options between thruster and e-motor
- Fully integrated package with controls-, DP- and automation system
- Digital Twin