

ANCHORING – WALK BACK OPERATION

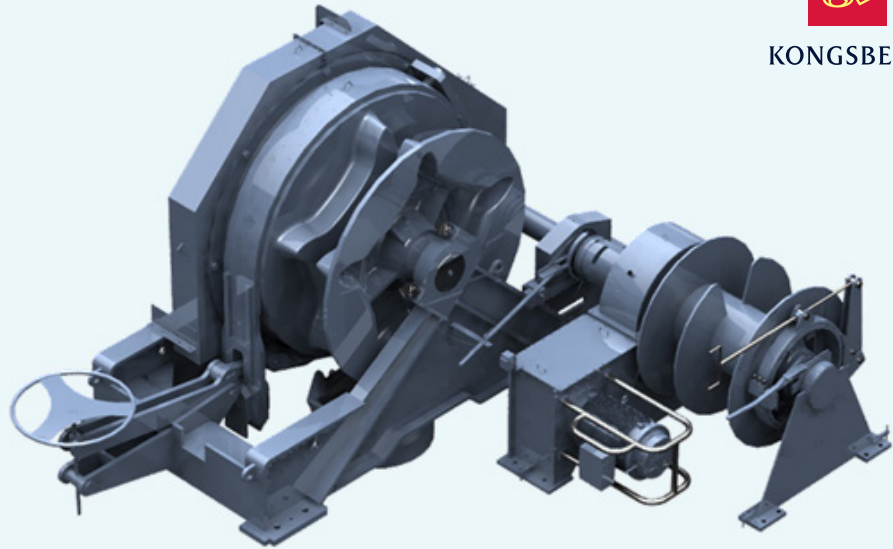

KONGSBERG



DECK MACHINERY - ANCHORING, MOORING & TOWING

Anchoring - Walk back operation

Recommended to carry out covering pre-inspection at least once a year or min 5-month prior docking.

Kongsberg Maritime has at least two features available in portfolio, which allow to operate CU with walk back method:

- Enlarged brake resistors, which allow to lower anchor to bottom of sea by consuming/radiating extensive amount of energy created by motor (which operate in generator mode). Bigger brake resistors will required suitable room with good ventilation.
- Active Front End (AFE) – where energy generated by motor in lowering operation is fed to vessel power grid.

Walk back modification is easy to combine with frequency converter upgrades.

Kongsberg Maritime
P.O.Box 483, NO-3601
Kongsberg, Norway

Switchboard: +47 815 73 700
Global support 24/7: +47 33 03 24 07
E-mail sales: km.sales@km.kongsberg.com
E-mail support: km.support@kongsberg.com