

MOORING ROPE LOAD MONITORING SYSTEM

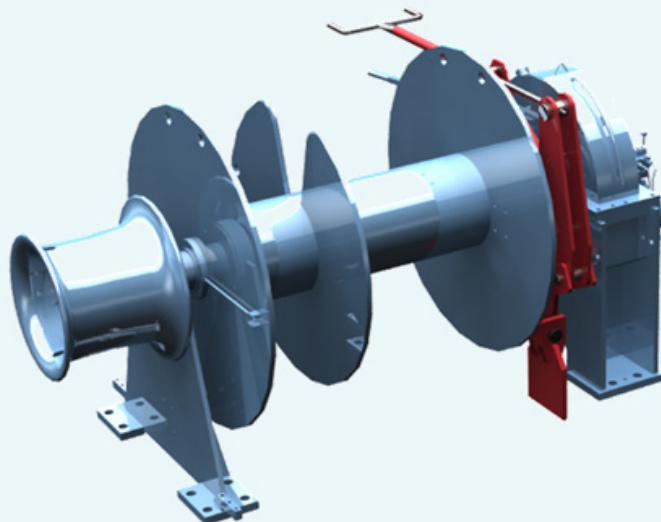

KONGSBERG



DECK MACHINERY - ANCHORING, MOORING & TOWING

For drums and change to OCIMF-type

Upgrade highlights:

- OCIMF MEG4 recommendation for all tankers since 2018
- Easy to retrofit also while vessel is sailing
- Replacement of brake band and brake pin
- Adding small amount of wiring
- Can be done separately if requested

SYSTEM EXAMPLE

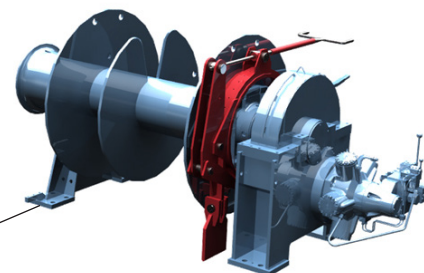

Break pin load sensor at winch



Sensor amplifier at starter
Signal options:
0...20 mA
4...20 mA
0...10 VDC

PLC + I/O at bridge



Touch screen at bridge

Amplifier signal can be connected to vessels monitoring system when neither panel nor PLC are required

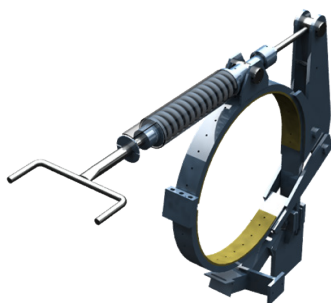

Kongsberg Maritime
P.O.Box 483, NO-3601
Kongsberg, Norway

Switchboard: +47 815 73 700
Global support 24/7: +47 33 03 24 07
E-mail sales: km.sales@km.kongsberg.com
E-mail support: km.support@kongsberg.com