

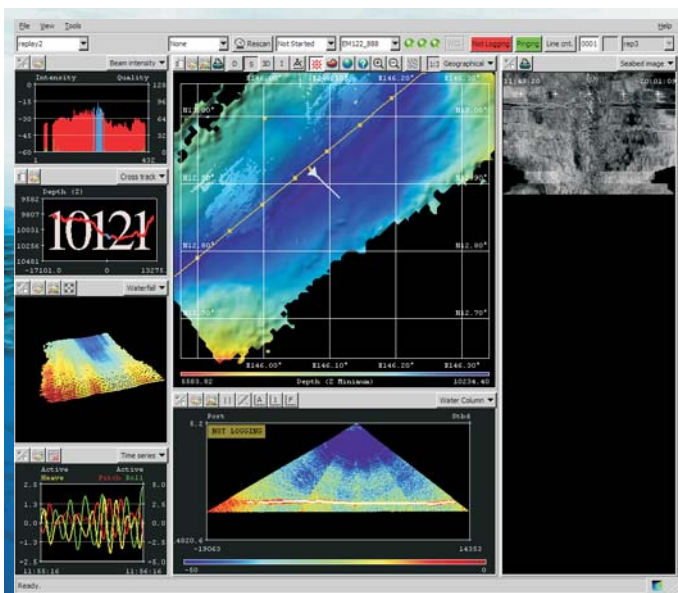

KONGSBERG

Maintenance Manual

EM 122 Multibeam echo sounder



Kongsberg EM 122 Multibeam echo sounder

Maintenance Manual

Kongsberg Maritime

Document history

| | | |
|-------------------------|-----------|----------------|
| Document number: 309059 | | |
| Rev. A | Mars 2009 | First version. |

Note

The information contained in this document remains the sole property of Kongsberg Maritime AS. No part of this document may be copied or reproduced in any form or by any means, and the information contained within it is not to be communicated to a third party, without the prior written consent of Kongsberg Maritime AS.

Kongsberg Maritime AS endeavours to ensure that all information in this document is correct and fairly stated, but does not accept liability for any errors or omissions.

Warning

The equipment to which this manual applies must only be used for the purpose for which it was designed. Improper use or maintenance may cause damage to the equipment and/or injury to personnel. The user must be familiar with the contents of the appropriate manuals before attempting to operate or work on the equipment.

Kongsberg Maritime disclaims any responsibility for damage or injury caused by improper installation, use or maintenance of the equipment.

Comments

To assist us in making improvements to the product and to this manual, we welcome comments and constructive criticism.

e-mail: km.documentation@kongsberg.com

Kongsberg Maritime AS

Strandpromenaden 50
P.O.Box 111
N-3191 Horten,
Norway

Telephone: +47 33 02 38 00
Telefax: +47 33 04 47 53
www.kongsberg.com
subsea@kongsberg.com



KONGSBERG

Table of contents

| | | |
|----------|---|-----------|
| 1 | ABOUT THIS MANUAL | 7 |
| 1.1 | General | 7 |
| 1.2 | Maintenance philosophy..... | 7 |
| 1.3 | System overview | 8 |
| 1.4 | System characteristics | 10 |
| 1.5 | General safety rules | 12 |
| 2 | TECHNICAL SPECIFICATIONS | 14 |
| 2.1 | Interfaces | 14 |
| 2.2 | Physical specifications..... | 15 |
| 2.3 | Power requirements..... | 16 |
| 2.4 | Environmental and EMC specifications | 17 |
| 2.5 | System performance data | 17 |
| 3 | CABLE LAYOUT AND INTERCONNECTIONS | 19 |
| 3.1 | System cabling | 20 |
| 3.1.1 | Cable layout | 20 |
| 3.1.2 | Shipyards and system cables | 20 |
| 3.1.3 | Shipyards cables | 20 |
| 3.1.4 | System cables | 20 |
| 3.2 | Operator Station cables | 21 |
| 3.3 | Transceiver Unit cables | 22 |
| 3.3.1 | Transceiver Unit front view | 23 |
| 3.3.2 | Transceiver Unit rear view..... | 24 |
| 3.3.3 | Power and control cables between sub-racks – rear view | 24 |
| 3.4 | Transducer cables | 27 |
| 3.4.1 | Transmit array cables | 28 |
| 3.4.2 | Receive array cables | 31 |
| 3.4.3 | Cables between Tx Junction Box(es) and Transceiver Unit | 33 |
| 3.4.4 | Cables between Preamplifier Unit and Transceiver Unit | 36 |
| 4 | OPERATOR STATION | 39 |
| 4.1 | HWS overview | 39 |
| 4.2 | Technical description..... | 40 |
| 4.3 | HWS circuit boards and modules..... | 40 |
| 5 | TRANSCEIVER UNIT | 41 |
| 5.1 | Theory of operation | 42 |
| 5.1.1 | External synchronisation and remote on/off | 43 |
| 5.1.2 | Clock sync 1 PPS..... | 45 |
| 5.2 | Processing and receiver rack | 46 |

| | | |
|-----------|--|------------|
| 5.3 | Transmitter rack..... | 49 |
| 5.4 | High Voltage rack..... | 50 |
| 5.5 | Circuit board descriptions | 53 |
| 5.5.1 | cPCI Power Supply..... | 53 |
| 5.5.2 | CPU Board with PMC Module | 55 |
| 5.5.3 | Kontron CP 6011 pentium CPU BOARD | 57 |
| 5.5.4 | BSP 67B Board | 60 |
| 5.5.5 | Ethernet Switch Board – Gigabit..... | 62 |
| 5.5.6 | Ethernet Switch Board – Megabit | 64 |
| 5.5.7 | Power Supply PSU 6V | 66 |
| 5.5.8 | RX32 receiver board..... | 67 |
| 5.5.9 | RX RIO – Rear Interface Board | 73 |
| 5.5.10 | RXP RIO – Rear Interface Board | 74 |
| 5.5.11 | BSP RIO – Rear Interface Board | 75 |
| 5.5.12 | Rear I/O Interface Board (Kontron) | 76 |
| 5.5.13 | Raw data logger interface (RDL) | 78 |
| 5.5.14 | TX36 transmitter board | 79 |
| 5.5.15 | Power Supply PSU 12V | 85 |
| 5.5.16 | TXP RIO – Rear Interface Board | 87 |
| 5.5.17 | TX RIO – Rear Interface Board | 88 |
| 5.5.18 | Power Supply PSU 170V | 89 |
| 5.5.19 | Capacitor board | 91 |
| 5.5.20 | HVP RIO | 92 |
| 6 | PREAMPLIFIER UNIT | 94 |
| 6.1 | Theory of operation..... | 95 |
| 6.2 | Preamplifier Unit details..... | 96 |
| 6.3 | Circuit board descriptions | 96 |
| 6.3.1 | Preamplifier (DP16)..... | 97 |
| 6.3.2 | Preamplifier Unit Power Supply (PAPS)..... | 101 |
| 6.3.3 | Preamplifier Backplane | 102 |
| 7 | TX JUNCTION BOXES | 106 |
| 8 | TROUBLESHOOTING..... | 107 |
| 8.1 | BIST tests | 107 |
| 9 | REPLACEMENT PROCEDURES | 110 |
| 9.1 | Procedures for Transceiver Unit..... | 111 |
| 9.2 | Power Supply | 112 |
| 9.3 | Fuse replacement..... | 113 |
| 9.4 | Fan drawers | 113 |
| 10 | MAINTENANCE PROGRAM | 115 |
| 10.1 | Before every survey (alongside)..... | 115 |
| 10.2 | Before every survey (offshore)..... | 115 |

| | | |
|-----------|--|------------|
| 10.3 | Every time used | 116 |
| 10.4 | Every 6 months..... | 116 |
| 10.5 | Every dry-docking..... | 116 |
| 11 | SPARE PARTS..... | 118 |
| 12 | DRAWING FILE | 121 |
| 12.1 | Rx Module..... | 124 |
| 12.2 | Tx module..... | 125 |
| 12.3 | Tx array mounting frame assembly 1 degree | 126 |
| 12.4 | Tx array | 127 |
| 12.5 | Rx array | 129 |
| 12.6 | Rx array with casing – 2 degree | 130 |
| 12.7 | Preamplifier | 132 |
| 12.8 | Tx Junction Box | 133 |
| 12.9 | Transducer cable layout..... | 134 |
| 12.10 | Generic RS-232 Serial line | 136 |
| 12.11 | Generic RS-232 Serial line | 137 |
| 12.12 | Generic coax cable | 138 |
| 12.13 | Sound speed probe interface..... | 139 |
| 12.14 | Trigger in/out..... | 140 |
| 12.15 | Control signals..... | 141 |
| 12.16 | Control signals..... | 142 |
| 12.17 | Standard AC power cable..... | 143 |
| 12.18 | Ethernet cable with RJ45..... | 144 |
| 12.19 | Ethernet cables 0.5x1 and 1x1 degree system..... | 145 |
| 12.20 | Ethernet cables 1x2 degree system..... | 146 |
| 12.21 | VGA/SVGA Display cable | 147 |
| 12.22 | HWS and display..... | 148 |
| 12.23 | USB cable..... | 149 |
| 12.24 | Keyboard cable..... | 150 |
| 12.25 | Mouse cable..... | 151 |
| 12.26 | Parallel printer | 152 |
| 12.27 | Tx transducer cables from junction boxes to TRU..... | 153 |
| 12.28 | Tx transducer cables to transducer array | 155 |
| 12.29 | Rx transducer cable from Preamplifier to TRU..... | 156 |
| 12.30 | Preamplifier Unit cable from array..... | 157 |

1 ABOUT THIS MANUAL

1.1 General

This is the maintenance manual for the EM 122 Multibeam echo sounder system.

The manual contains detailed descriptions of each of the units in the system. Each circuit board and mechanical assembly is described. The manual also describes the troubleshooting process based on the Built-In Self test (BIST) software, and it includes procedures for disassembly and reassembly of the replaceable items.

This manual does not describe the maintenance of the Operator Station and the peripheral devices (printers, plotters and sensors). For information about these items, refer to the applicable manufacturer's documentation.

1.2 Maintenance philosophy

Kongsberg Maritime defines three levels for maintenance.

- 1 **Organizational:** You will only perform limited preventive and corrective maintenance on the system. There is no need for technical education or training, and no need for any instruments. Typical tasks are exterior cleaning, or changing fuses.
- 2 **Intermediate:** You will perform overall preventive and corrective maintenance on the system. It is recommended that you are an educated engineer with experience from computer, mechanical or survey systems. It is further expected that you can use standard electronic instruments, such as an oscilloscope. You should be trained by Kongsberg Maritime to perform maintenance on the system. Typical tasks may include troubleshooting, testing and circuit board replacement.
- 3 **Depot:** You will perform detailed maintenance on the system and on the circuit boards and modules. You must be an educated engineer with experience from computer, mechanical or survey systems. It is further expected that you can use standard electronic instruments, such as an oscilloscope. You should be trained by Kongsberg Maritime to perform maintenance on the system. Typical tasks are circuit board repair.

Note _____

This manual is prepared for the intermediate level.

1.3 System overview

Key facts

The EM 122 is designed to perform seabed mapping to full ocean depth with an unsurpassed resolution, coverage and accuracy. The system is cost effective, reliable, and easily operated.

Compared with the EM 120 the EM 122 has up to four times the resolution in terms of sounding density through inclusion of multiping capability and more than twice the number of detections per swath. High density signal processing is a major improvement, to keep the acoustic footprint size small even for the outer beams in the swath. In typical ocean depths a sounding spacing of about 50 m across and along is achievable

The achievable swath width of the EM 122 is in the order of 30,000 m. This is obtained by using long FM chirps which improves the signal to noise ratio compared to CW pulses.

The sectors are frequency coded or have FM chirps, and they are transmitted sequentially at each ping. The sector steering is fully taken into account when the position and depth of each sounding is calculated, as is the refraction due to the sound speed profile, vessel attitude and installation angles. The pulse length and range sampling rate are variable with depth (auto or manual) for best resolution.

In shallow waters due care is taken to the near field effects through nearfield focusing individually applied in the different sectors.

The EM 122 applies different focus ranges for each of the transmit sectors which are used. Dynamic beam focusing is used for the reception beams.

The EM 122 operates at sonar frequencies around 12 kHz for high resolution.

The ping rate is mainly limited by the round trip travel time in the water up to a ping rate of 5 Hz.

Number of beams and soundings for each ping:

- 4 degrees receiver:
 - 144 beams giving 216 soundings in High Density mode
- 1 or 2 degrees receivers:
 - 288 beams or 576 beams in dual swath mode giving 432/864 soundings in High Density mode

Functionality to limit Mammal Harassment

The maximum sound intensity generated by the EM 122 is about 210 dB re 1 mPa. Maximum intensity is encountered in a thin wedge extending below the ship with an angular coverage of

about 150 degrees. The intensity level may be lowered by 10 or 20 dB by the operator, at the lowest level the intensity will be less than 180 dB re 1 mPa for ranges larger than 30 m from the transmit transducer. The EM 122 may be set in a mode to begin pinging with a flexible soft-start as a possible means of inducing marine mammals to leave the area of high intensity sound.

Transducer arrays

The EM 122 transducers are linear arrays in a Mills cross configuration with separate units for transmit and receive. The arrays are divided into modules. For both arrays 1 and 2 degrees beamwidths are standard options, and 4 degrees beamwidth is available for the receive array. The resulting array lengths are between 2 and 8 m.

Optionally the EM 122 transmit array can be delivered with a beamwidth of 0.5 degrees. The system can also be delivered with a non-standard number of modules to optimize beamwidth in accordance with the vessel hull shape and size.

Optional sub-bottom profiling

The receive transducer is wideband. In conjunction with a separate low frequency transmit transducer, the EM 122 may optionally be able to deliver sub-bottom profiling capabilities with a very narrow beamwidth. This system is known as the SBP 120 Sub-Bottom Profiler.

Acoustical seabed imaging

Integrated seabed acoustical imaging capability is included as standard. Software to use this data for automatic seabed classification is available.

Water column backscatter

A real time display window for water column backscatter is available. Logging of water column data and of raw stave data (before beamforming) is a system option.

Choice of operator softwares

The EM 122 is delivered as a complete stand-alone seabed mapping system. The Operator Station, a high-performance PC workstation, includes the necessary operator controls for setting up and running the system, data logging and system testing. The Seafloor Information System (SIS) by Kongsberg Maritime also includes an extensive set of graphical displays for data quality control, as well as system calibration and other tools which are required. SIS supports on-line real-time data cleaning to improve the overall survey efficiency.

Post-processing software for the EM 122 is available from Kongsberg Maritime and third part suppliers.

System drawing

Figure 1 EM 122 system units and interfaces with optional SBP120

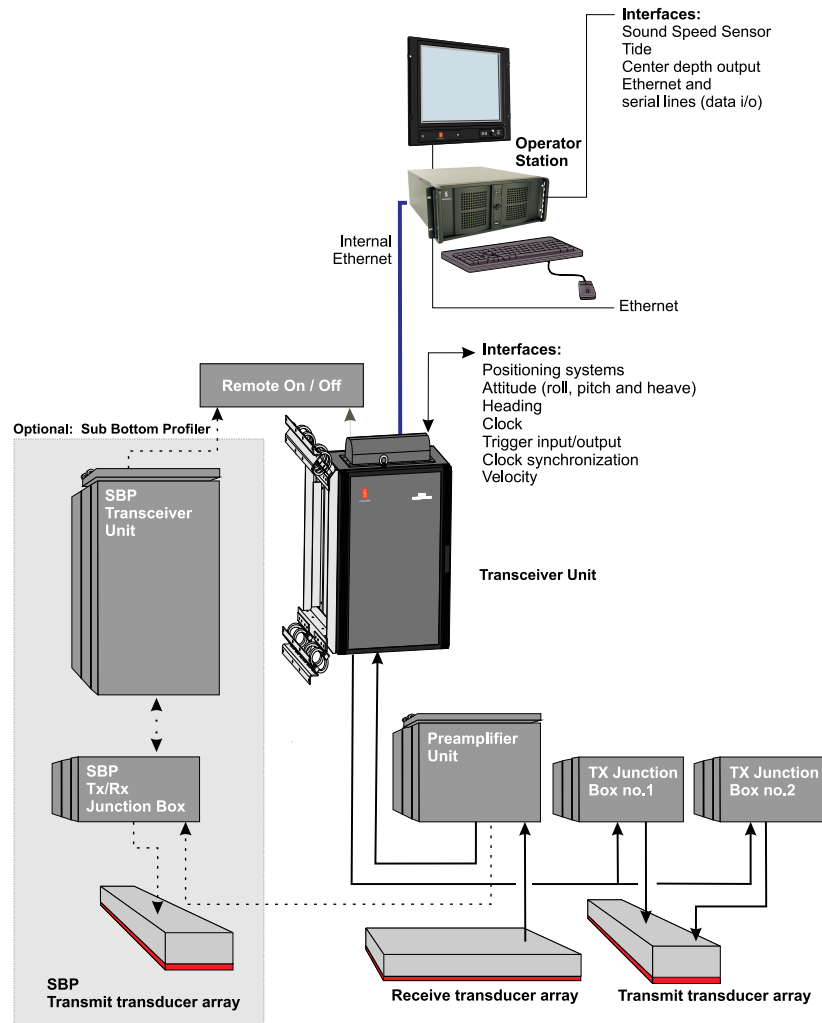

cd021012c

1.4 System characteristics

Main units

The basic Multibeam echo sounder multibeam echo sounder consists of these main units:

- Transducer Arrays
- Transceiver Unit
- Preamplifier Unit

- Tx Junction Boxes
- Operator Station

A complete mapping system will in addition include a vessel motion sensor, heading sensor, sound velocity sensor(s) and a positioning system.

Transducer arrays

The transmit transducer array contains up to 96 modules in accordance with the chosen beamwidth. Each module contains 18 elements arranged in rows of 6 elements. Each element is individually connected through the TX Junction Box to its corresponding transmitter in the Transceiver Unit. It can thus be driven with a unique amplitude level and phase to allow forming of the required transmit sectors with individual steering.

The receive transducer contains up to 16 modules in accordance with the chosen beamwidth. Each module contains 8 transducer staves, and these have individual electrical connections to their corresponding preamplifiers in the Preamplifier Unit. Each staff can thus be given unique amplitude and phase weighting to allow forming of the required receive beams. The receiving hydrophones have a wide bandwidth and can be used also as receivers for the low frequency signals used by the Multibeam echo sounder sub bottom profiler.

The flat and horizontally mounted transducers of the EM 122 makes the accuracy almost independent of variations in sound speed at the transducer depth, unless the roll and pitch are not too excessive.

Example with 1 m/s sound speed error: For a 70 degree steered beam and a 6 degree roll the error will be 0.23% of depth (angular error of 0.05 degrees). For a 60 degree beam, the error will be 0.06% of depth.

Installation of a sensor to allow real-time measurement of sound speed variation is provided for though, and is recommended to avoid a reduction in angular coverage in heavy seas. The system will take into account the sensor measurements in its calculations of beam pointing angles and raybending. The system is prepared for using sound velocity probes from Valeport or AML.

Transceiver Unit

The EM 122 Transceiver Unit contains all transmit and receive electronics, and the Processing Unit which performs the beamforming, bottom detection, and motion and sound speed corrections. It contains all interfaces for time-critical external sensors such as vessel attitude (roll, pitch, heading and heave),

vessel position and external clock. More than one sensor of each type may be connected simultaneously, with one in use but all logged.

The Transceiver Unit comprises three 19” sub-racks contained in a cabinet designed for bulkhead or deck mounting. The number of circuit boards will depend upon the chosen transducer configuration. Twisted pair Ethernet is used for data communication with the Operator Station.

Operator Station

The Operator Station of the EM 122 is the HWS (Hydrographic Work Station) high performance dual-processor PC workstation. The operator software is the Seafloor Information System (SIS). The HWS is dual bootable to either Linux® or Windows XP®.

SIS, as a minimum, allows setting the EM 122 installation and runtime parameters, data logging and running self-test on the system without restrictions.

The SIS software also includes functionality for survey planning, 2D and 3D geographical display of the survey results, seabed image and water column displays, plus real-time data cleaning algorithms.

The HWS is normally supplied with a 19” industrialized LCD monitor, spill-proof US keyboard and a standard optical mouse. Support for a second monitor is included. Optionally up to 4 monitors may be connected. The system storage capacity is three 250 GB high performance disks of which two are mirrored (Raid1) to safeguard critical raw data. The disks may optionally be supplied as removable units.

Preamplifier Unit

The EM 122 Preamplifier Unit preamplifies the signals from the hydrophones. The EM 122 Preamplifier Unit contains the preamplifiers for the receive signals. The unit also provides the frequency splitting circuitry to feed low frequency signals to the optional SPB 120 Sub-Bottom Profiler.

Tx Junction box(es)

The Tx Junction box serves as an interface routing box for easy transmit transducer cable installation. One or two units must be used depending on the chosen beamwidth

1.5 General safety rules

The system operates on 115 and/or 230 Vac, 50/60 Hz with a switch in the Transceiver Unit.

WARNING

This voltage can be lethal.

The following safety precautions must be followed at all times during installation and maintenance work:

- Always switch off all power before installation or maintenance. Use the main circuit breaker, and label the breaker with a warning sign that informs others that maintenance or installation work is being carried out on the system.
- Read and understand the first aid instructions for electric shock.
- For safety reasons during troubleshooting on the equipment with power ON, two persons should always be present.
- Whenever maintenance is carried out, it is essential that a first aid kit is available, and that the maintenance personnel are familiar with the first aid instructions for electrical shock.
- The various parts of the system are heavy. Make sure that the appropriate tools and certified lifting equipment are available, and that the personnel are trained in installation and maintenance work.

2 TECHNICAL SPECIFICATIONS

Note

Kongsberg Maritime AS is engaged in continuous development of its products and reserves the right to alter specifications without prior notice.

2.1 Interfaces

These interfaces are found on the Transceiver Unit and the Operator Station:

- Serial lines with operator adjustable baud rate, parity, data length and stop bit length for:
 - Motion sensor (roll, pitch, heave and optionally heading) in format supported by sensors from the main suppliers like Applinix , iXSEA, Coda, Kongsberg Maritime
 - Heading NMEA 0183 HDT or SKR82/LR60 or EM attitude format
 - Positions in either Simrad 90, NMEA 0183 GGA or GGK format
 - External clock in NMEA 0183 ZDA format, Trimble UTC
 - Sound speed at transducer
 - Sea level height (tide)
 - Single beam echo sounder depths
 - Output of depth straight down in NMEA 0183 DPT format
- Interface for 1PPS (pulse per second) clock synchronisation signal
- Firewire interface for external data storage device
- SATA and Firewire interface for external data storage device (tape or disk)
- USB 2.0 interfaces for data storage, printing or plotting
- Parallel interface for Postscript colour graphics printer/plotter
- Ethernet interface for velocity input needed for Doppler compensation in chirp mode.
- Gbit Ethernet interface for input of sound speed profile, tide and echo sounder depths, and output of all data normally logged to disk

2.2 Physical specifications

Transmit transducer – Tx

Tx module:

- **Length:** 179 mm / 131.4 mm
- **Width:** 760 mm (780 mm with frame)
- **Height:** 197 mm (261.5 mm with 1 degree frame, 249.5 mm with 2 degrees frame)
- **Weight in air/water:** 58 kg / 46 kg

Frame length

- 15200 mm (0.5 degree)
- 7770 mm (1 degree)
- 4020 mm (2 degrees)

Tx mounting frame:

- **Weight in air/water:** 1635 kg / 1427 kg (1 degree)

Receive transducer – Rx

Rx module:

- **Length:** 447 mm
- **Width:** 342 mm (420 mm with frame)
- **Height:** 120 mm (177 mm with frame)
- **Weight in air/water:** 24 kg / 6 kg

Frame length

- 7200 mm (1 degree)
- 3600 mm (2 degrees)
- 1808 mm (4 degrees)

Rx mounting frame

- **Weight in air/water:** 700 kg / 611 kg (1 degree)
- **Weight in air/water:** 340 kg / 297 kg (2 degree)

Receive transducer ice window

- **Tx – Weight in air/water:** 200 kg / 55 kg
- **Rx – Weight in air/water:** 530 kg / 412 kg (1 degree)
- **Rx – Weight in air/water:** 310 kg / 241 kg (1 degree)

Transceiver Unit

- **Length:** 1107 mm
- **Width:** 540 mm

- **Height:** 750 mm
- **Weight:** Approximately 200 kg

Rx Preamplifier Unit

- **Height:** 920 mm
- **Width:** 600 mm
- **Depth:** 630 mm
- **Weight:** Approximately 96 kg

Tx Junction Box

- **Height:** 440 mm
- **Width:** 500 mm
- **Depth:** 303 mm
- **Weight:** Approximately 15 kg

Operator Station

- **Height:** 4U – 178 mm
- **Width:** 427 mm (excluding rack fixing brackets)
- **Depth:** 480 mm (excluding handles and connectors)
- **Weight:** Approximately 20 kg
- **Power:** 115 Vac (60 Hz) and 230 Vac (50 Hz), < 250 W

19" inch LCD monitor

- **Height:** 444 mm (excluding mounting brackets)
- **Width:** 483 mm (excluding mounting brackets)
- **Depth:** 68 mm (excluding mounting brackets)
- **Weight:** 12 kg (approximately with bracket)
- **Power:** 115 Vac (60 Hz) and 230 Vac (50 Hz), 100 W (max)

2.3 Power requirements

Operational voltage and frequency

AC voltage: 115/230 Vac \pm 10%, 47 – 63 Hz

Acceptable transients

- Short time (max. 2 sec): \pm 20%, 42 – 69 Hz
- Spikes (max. 50 μ s): < 1000 V

Transceiver Unit:

- 0.5° x 1°: < 2000W
- 1° x 1°: < 2000W
- 1° x 2°: < 1900W

- 2° x 2°: < 1200W
- 2° x 4°: < 1200W
- The single phase supply must be protected with 16A slow-blow fuses.

Operator Station: < 250W

LCD monitor: < 60W

Preamplifier Unit: < 300W

Tx Junction Box: None

Note _____

*For 115 Vac operation, please contact
km.hydrographic.support@kongsberg.com*

Power interrupts

Menu settings, all parameters and the sound speed profile are stored on the Operator Station's harddisk during operation, so operation can continue after power interruption. However, the file system may be damaged, so the use of an uninterruptable power supply (UPS) is highly recommended.

2.4 Environmental and EMC specifications

The system meets all requirements of the IACS E10 specification.

The Transceiver Unit meet the additional stronger requirements of the IEC 60945 specification.

The Operator Station and the LCD monitor are both IP22 rated. The Transceiver Unit is IP54 rated.

2.5 System performance data

- **Main operational frequency:** 12 kHz
Frequencies in the range of 10.50 to 13.5 kHz are employed to code the different transmit sectors.
- **Beamwidths:** 0.5x1, 1x1, 1x2, 2x2 or 2x4 degrees
Other beamwidth combinations are possible in accordance with the number of transducer modules installed.
- **Beam spacing:** Equidistant, equiangle or in between
- **Coverage sector:** Up to 150 degrees
- **Transmit beam steering:** Stabilized for roll, pitch and yaw
- **Receive beam steering:** Stabilized for roll
- **Depth range from transducers:** 20 to 11.000 meters
- **Pulse lengths:** 2, 5 and 15 ms CW and up to 100 ms FM

- **Range sampling rate: 3 kHz**

| System version | Number of beams and soundings | | | |
|--|-------------------------------|-------|-------|-------|
| | 0.5 x 1 and 1 x 1 | 1 x 2 | 2 x 2 | 2 x 4 |
| Number of beams/swath | 288 | 288 | 288 | 144 |
| Number of soundings/swath | 432 | 432 | 432 | 216 |
| Number of soundings/ping | 2 | 2 | 2 | 2 |
| Number of soundings/ping Dual swath | 864 | 864 | 864 | 432 |

3 CABLE LAYOUT AND INTERCONNECTIONS

Note

For more detailed information about this chapter – see our installation manual for EM 122

Topics

- *System cabling* on page 20
- *Operator Station cables* on page 21
- *Transceiver Unit cables* on page 22
- *Transducer cables* on page 27
- *Cable details* on page 121

The standard cables used between the EM 122 system units and between the units and their external devices are shown here. For larger installations where the EM 122 is a subsystem, the cables will also be shown in the cable layout plan and interconnection diagram specific for the vessel into which the system is installed.

Note

All cable connections may have to be made in accordance with the guidelines laid down by the vessel's classification society.

Contact information:

DNV

Corporate Headquarters

Veritasveien 1

1322 Høvik Norway

<http://www.dnv.com>

3.1 System cabling

3.1.1 Cable layout

The interconnection cables are identified on the cable plan drawings. Each cable is then listed in the corresponding list, which refer to the required cable specifications. On the following pages, each cable is identified with the appropriate terminations.

3.1.2 Shipyard and system cables

Each individual cable is identified on the cable plan. The cables fall into two categories:

- Cables provided by the installation shipyard or owner
- System cables supplied with the delivery

3.1.3 Shipyard cables

The cables that must be provided by the shipyard or owner are identified as such in the descriptions. Note that the cable specifications given are the minimum specifications.

For each cable, the following information is provided:

- Connection to be made on each end of the cable (including system unit, terminal board identification and plug/socket to be used)
- Number of cores
- Recommended cable type
- Minimum cable specifications

The necessary considerations must be taken to suit special requirements. Kongsberg Maritime accepts no responsibility for damage to the system or reduced operational performance if this is caused by improper cabling.

3.1.4 System cables

Several cables will be supplied with the system. Such cables normally comprise power cables, and interconnection cables for computers and/or workstations. These cables will normally be delivered with the units.

3.2 Operator Station cables

The illustration and the list below specifies each cable used on the EM 122 Operator Station. References are made to detailed cable drawings in the EM 122 installation manual.

Note that this information includes several cables that may not be in use on all installations.

Figure 2 Operator Station cables

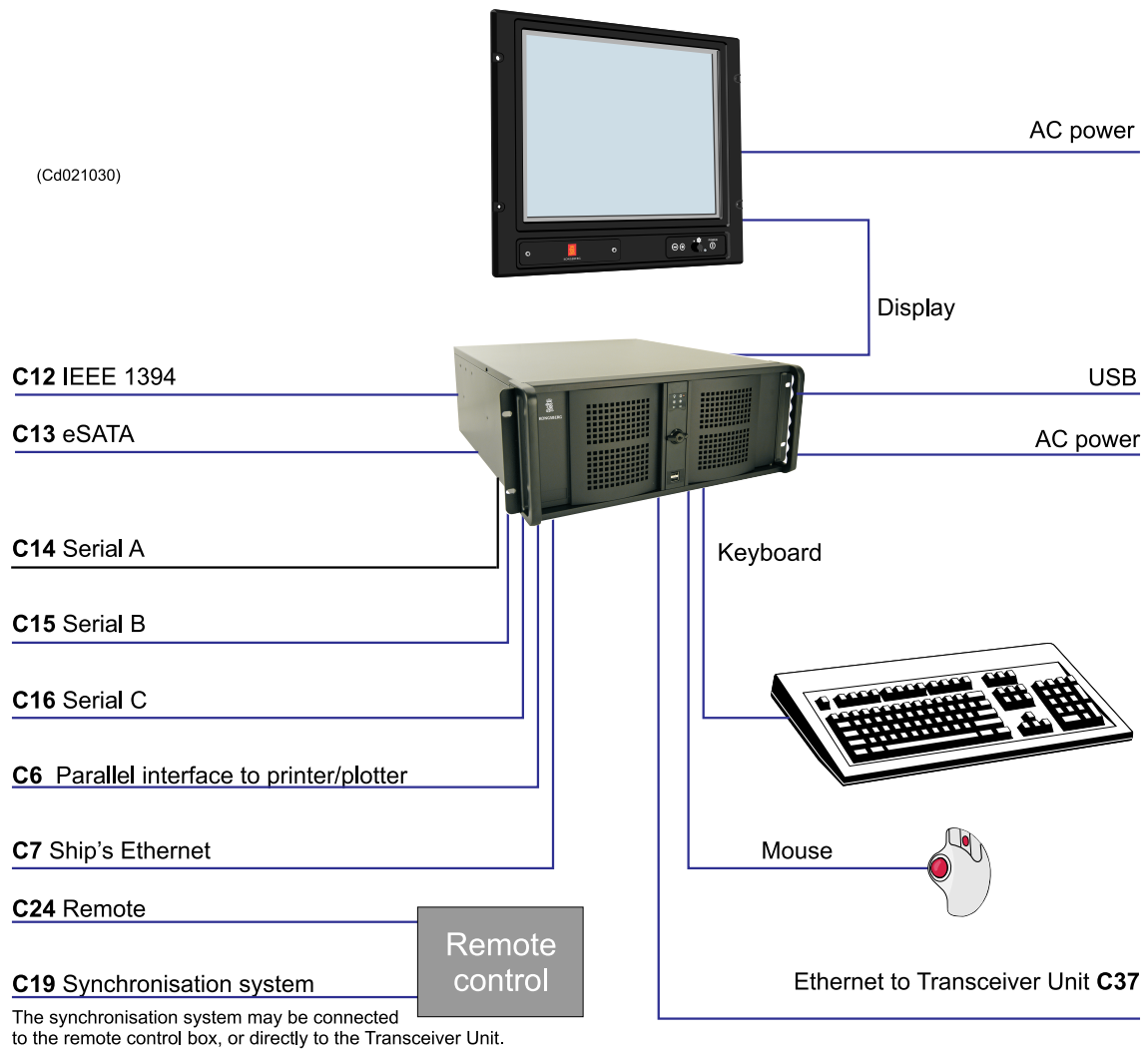

3.3 Transceiver Unit cables

The illustrations and the cable lists below specify each cable used on the EM 122 Transceiver Unit. References are made to detailed cable drawings. Note that this information includes several cables that may not be in use on all installations.

Figure 3 EM 122 Transceiver Unit overview of interfaces

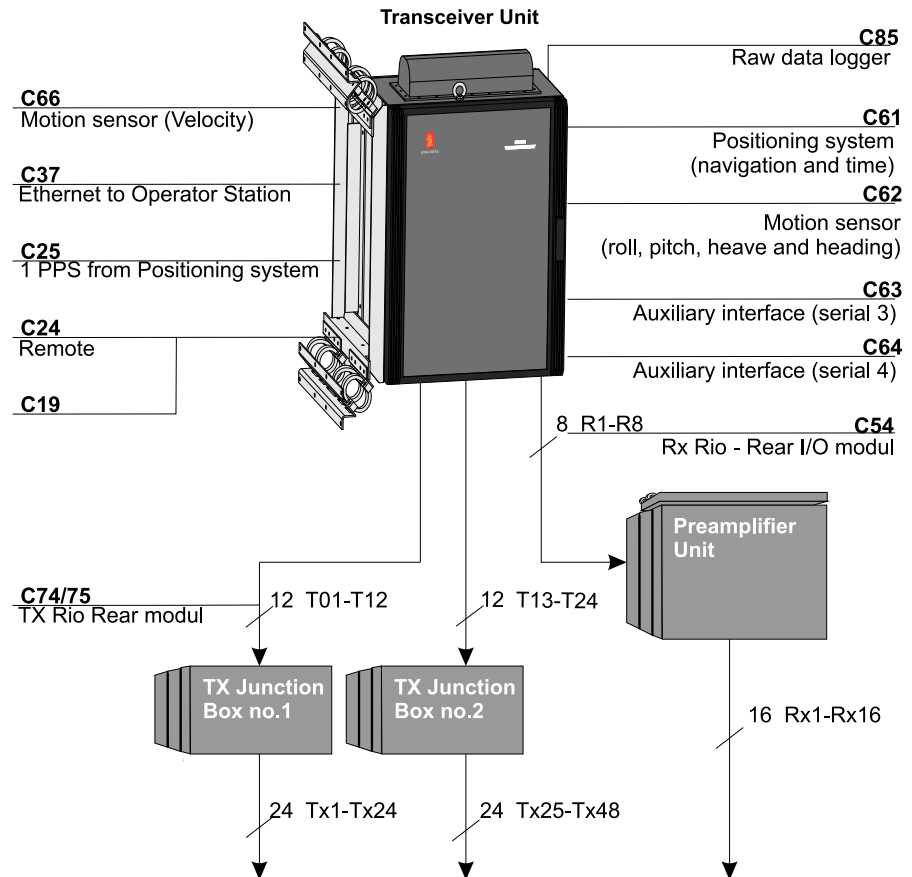

(Cd021049-001)

3.3.1 Transceiver Unit front view

Figure 4 EM 122 Transceiver Unit

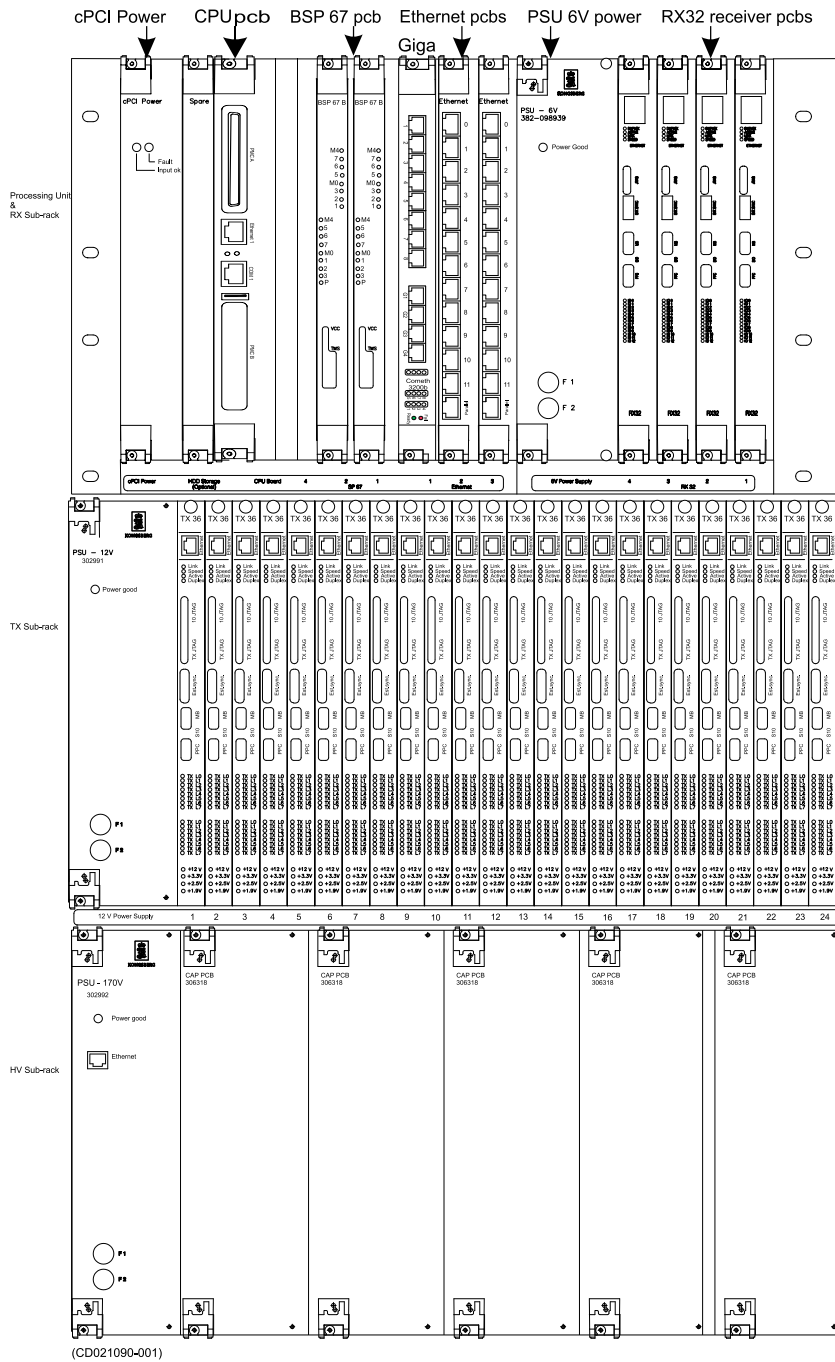

The cabling at the front of the Transceiver Unit is installed at the factory.

3.3.2 Transceiver Unit rear view

Figure 5 Transceiver Unit 0.5 x 1 degree / 1 x 1 degree

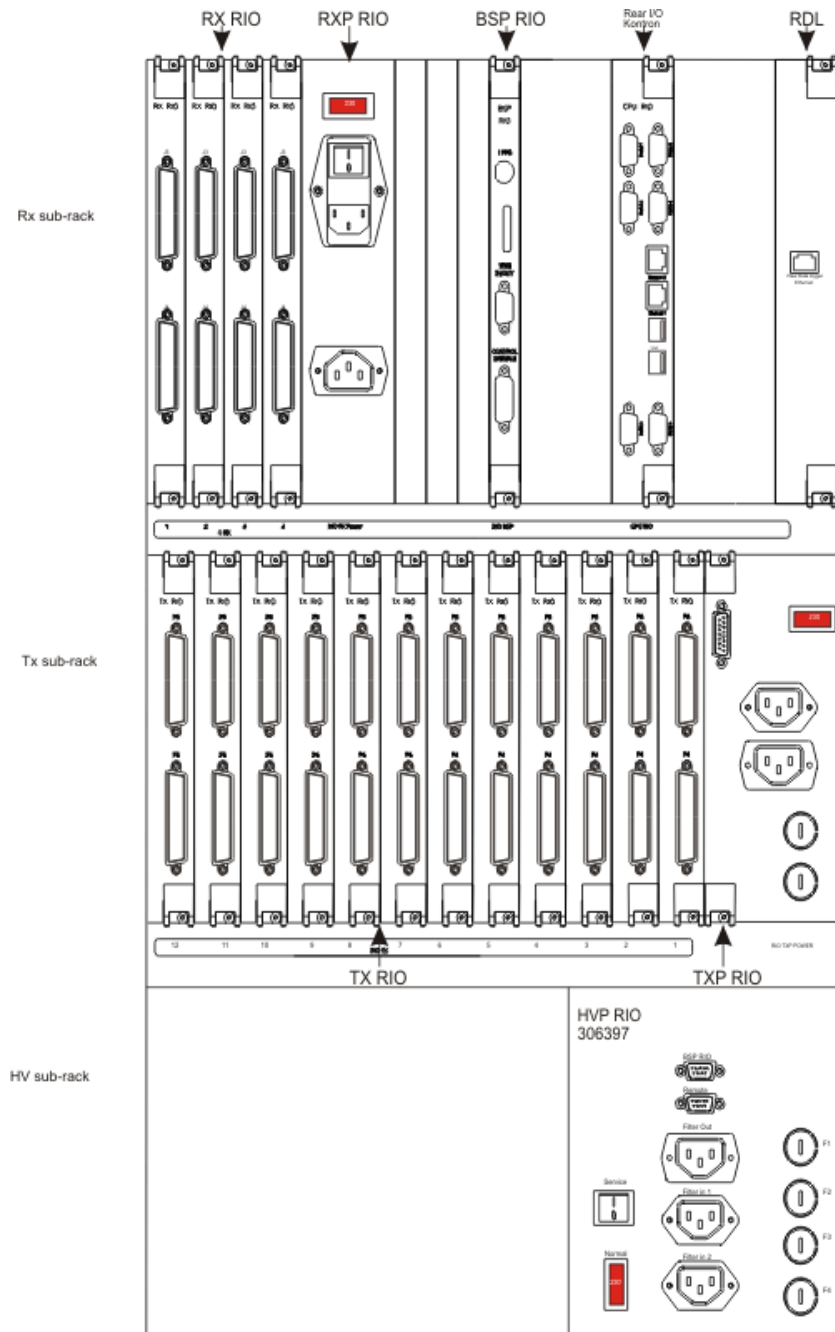

(CD21930A)

3.3.3 Power and control cables between sub-racks – rear view

This drawing shows the power supply cable connection between the sub-racks, at the rear of the Transceiver Unit.

Number 1 – 2 (see *Transceiver Unit sub-racks, rear view* on page 26) in the High Voltage sub-rack must be connected to the ships main AC power supply.

Number 3 is not used.

Figure 6 Transceiver Unit sub-racks, rear view

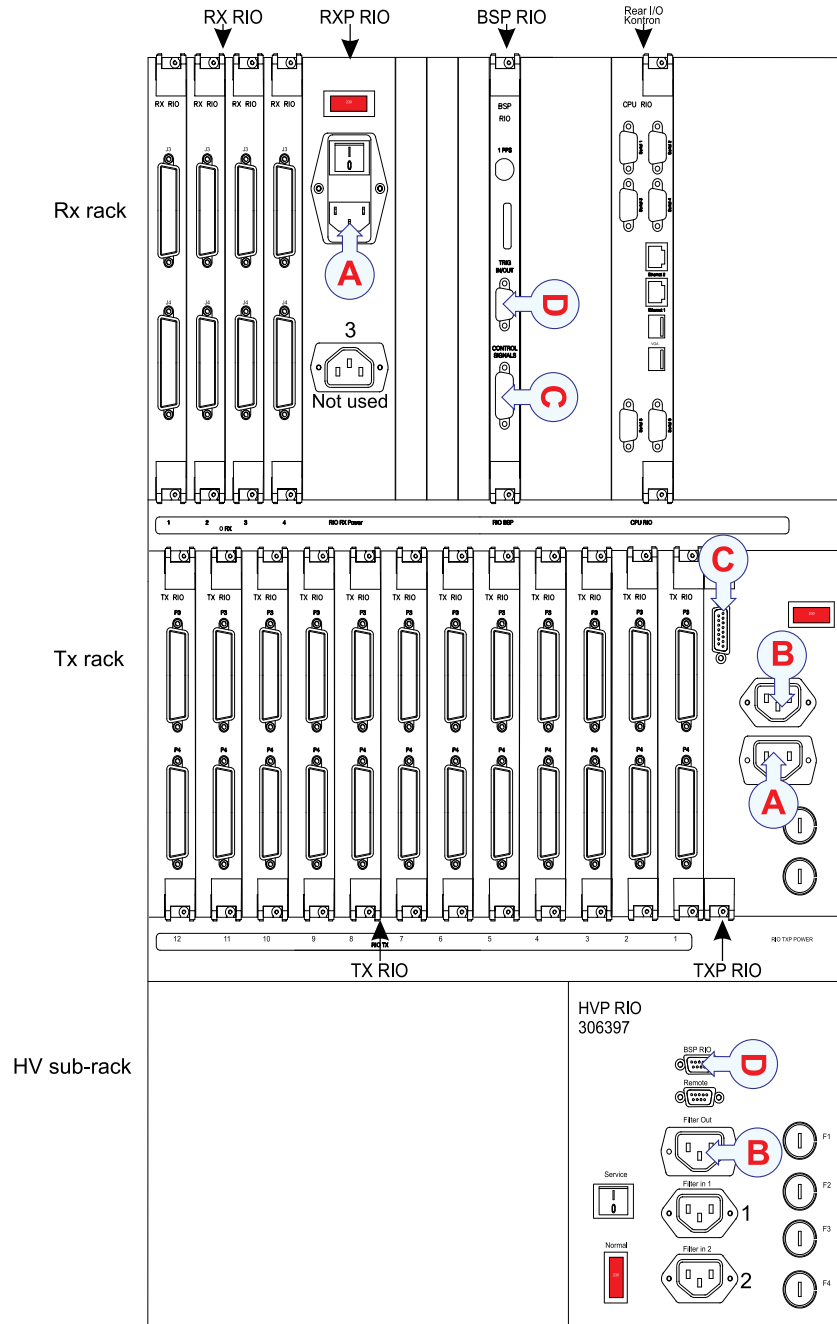

(CD21933)

- A – Power cable between TxP Rio and RxP Rio
- B – Power cable between TxP Rio and HVP Rio
- C – Connection cable between TxP Rio and BSP Rio for control signals
- D – Connection cable between HVP Rio and BSP Rio for trig in/out signals

3.4 Transducer cables

The transducer cables between the Tx Junction Boxes, Preamplifier Unit, Transceiver Unit and transducer arrays are all supplied by Kongsberg Maritime with the system.

For overview of the transducer cabling, see *Drawing file* on page 121

The physical number of cables depends on the chosen system beamwidth as shown the following tables.

Table 1 Tx Cables

| Tx Cables | |
|-----------------|--|
| System beamwith | Number of transducer modules = Number of cables from Tx transducer array to Tx Junction Box(es) |
| 0.5 degree | 96 |
| | The number of Tx junction boxes to be decided. |
| 1 degree | 48 |
| | Two Tx Junction Boxes are used. Each of these are connected to the Transceiver Unit with 12 cables, making a total of 24 cables. |
| 2 degrees | 24 |
| | One Tx Junction Box is used. This is connected to the Transceiver Unit with 12 cables. |

Table 2 Rx Cables

| Rx Cables | |
|-----------------|---|
| System beamwith | Number of transducer modules = Number of cables from Rx transducer array to Preamplifier Unit |
| 1 degree | 16 |
| | The Preamplifier Unit is connected to the Transceiver Unit with 8 cables. |
| 2 degrees | 8 |
| | The Preamplifier Unit is connected to the Transceiver Unit with 4 cables. |
| 4 degrees | 4 |
| | The Preamplifier Unit is connected to the Transceiver Unit with 2 cables. |

The following cable information is available both in the EM 122 installation and maintenance manuals. The cable markings are normally recorded in the installation manual first, and it is recommended to copy these records to the maintenance manual later.

The transducer cables between the Tx Junction Boxes, Preamplifier Unit, Transceiver Unit and transducer arrays are all supplied by Kongsberg Maritime with the system.

For overview of the transducer cabling, see *Drawing file* on page 121

3.4.1 Transmit array cables

Each transducer module and its cable is identified with a serial number as follows

Tx<nnn>

where <nnn> is a numerical value.

The cables between the Tx Junction Box(es) and the Transceiver Unit are identified as follows:

T<n>/<x>

where <n> is a number between 1 and 12 and <x> is a number between 13 and 24. In a 1-degree Tx system, 12 cables are connected from each Tx Junction Box to the Transceiver Unit. Two identical sets of cables are then provided, the first set (T 1/13 to T12/24) are used from Tx Junction Box no.1 to sockets Tx Rio 1 through Tx Rio 6 on the Transceiver Unit. The second set is used from Tx Junction Box no. 2 to sockets Tx Rio 7 through Tx Rio 12 on the Transceiver Unit.

Each transducer module is also identified by its physical location in the array (frame). This location number must be recorded during the installation of the transducer modules, and written down in the tables provided in this chapter.

Note _____

In order to ensure proper operation by the EM 122 system, it is of vital importance that the physical location of the transducer modules fits the designated channel number in the transmit and receiver circuitry.

The Tx transducer array is physically positioned in the fore-and aft direction under the hull.

- Transducer module number 1 is always the most forward module.
- Module number 2 is the second forward, and so on.

During installation, you can select any Tx module you wish and place them in random order in the frame. However, you **MUST** write down the serial number on each module in the order they have been positioned in the frame, so that you later can identify the modules in positions 1, 2, 3 and so on.

The connections to the Tx Junction Box(es) are made with 25-pin “D-sub” connectors.

Note

During the installation of the transmit array, you must fill in the table below.

In a 2 degree system, you will only need the first 24 modules.

The cables from module 1 must point to port.

0.5 degree system is not documented yet.

A “dummy” module shall be installed at each end of the Tx transducer array.

Table 3 Location of Tx modules

| Tx Junction Box(es) | | |
|--|-----------------------------|------------------------------|
| Physical position (Channel) | Module serial number | Socket identification |
| Tx Junction Box no. 1 | | |
| 1 (forward) | | Tx 1/25 |
| 2 | | Tx 2/26 |
| 3 | | Tx 3/27 |
| 4 | | Tx 4/28 |
| 5 | | Tx 5/29 |
| 6 | | Tx 6/30 |
| 7 | | Tx 7/31 |
| 8 | | Tx 8/32 |
| 9 | | Tx 9/33 |
| 10 | | Tx 10/34 |
| 11 | | Tx 11/35 |
| 12 | | Tx 12/36 |
| 13 | | Tx 13/37 |
| 14 | | Tx 14/38 |
| 15 | | Tx 15/39 |
| 16 | | Tx 16/40 |
| 17 | | Tx 17/41 |
| 18 | | Tx 18/42 |
| 19 | | Tx 19/43 |
| 20 | | Tx 20/44 |
| 21 | | Tx 21/45 |
| 22 | | Tx 22/46 |
| 23 | | Tx 23/47 |
| 24 | | Tx 24/48 |
| Tx Junction Box no. 2 (1 degree only) | | |

Table 3 Location of Tx modules (cont'd.)

| Tx Junction Box(es) | | |
|--------------------------------|----------------------|-----------------------|
| Physical position (Channel) | Module serial number | Socket identification |
| 25 | | Tx 1/25 |
| 26 | | Tx 2/26 |
| 27 | | Tx 3/27 |
| 28 | | Tx 4/28 |
| 29 | | Tx 5/29 |
| 30 | | Tx 6/30 |
| 31 | | Tx 7/31 |
| 32 | | Tx 8/32 |
| 33 | | Tx 9/33 |
| 34 | | Tx 10/34 |
| 35 | | Tx 11/35 |
| 36 | | Tx 12/36 |
| 37 | | Tx 13/37 |
| 38 | | Tx 14/38 |
| 39 | | Tx 15/39 |
| 40 | | Tx 16/40 |
| 41 | | Tx 17/41 |
| 42 | | Tx 18/42 |
| 43 | | Tx 19/43 |
| 44 | | Tx 20/44 |
| 45 | | Tx 21/45 |
| 46 | | Tx 22/46 |
| 47 | | Tx 23/47 |
| 48 | | Tx 24/48 |

Figure 7 Junction Box

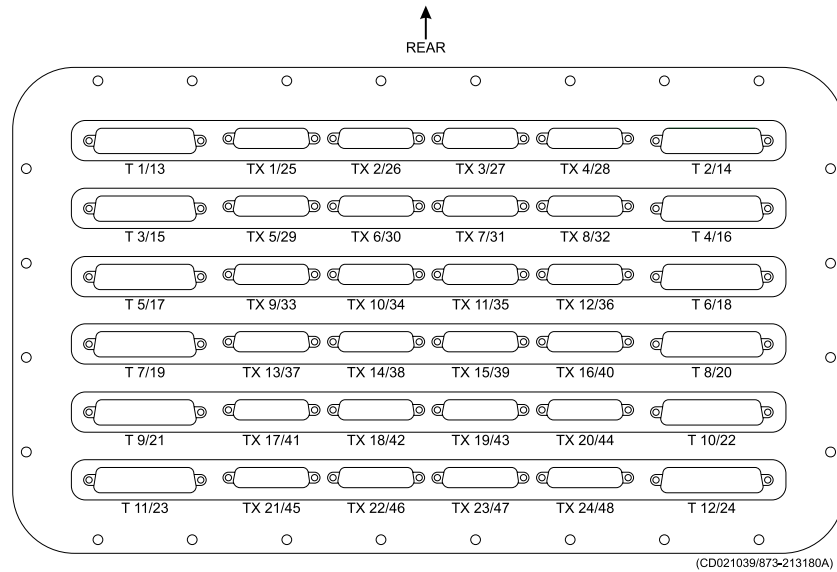

3.4.2 Receive array cables

Each transducer module and its cable is identified with a serial number as follows

Rx<nnn>

where <nnn> is a numerical value.

Each transducer module is also identified by its physical location in the array (frame). This location number must be recorded during the installation of the transducer modules, and written down in the tables provided in this chapter.

Note

In order to ensure proper operation by the EM 122 system, it is of vital importance that the physical location of the transducer modules fits the designated module number in the transmit and receive circuitry.

The cables between the Preamplifier Unit and the Transceiver Unit are identified as follows

R<n>

where <n> is a number between 1 and 8.

The Rx transducer array is physically positioned in athwartship direction under the hull.

- Transducer module number **1** is always the first on the port side.
- Module number **2** is the second on the port side, and so on.

Location of the first module in each array (example) on page 32

During installation, you can select any Rx module you wish and place them in random order in the frame. However, you **MUST** write down the serial number on each module in the order they have been positioned in the frame, so that you later can identify the modules in positions 1, 2, 3 and so on.

Figure 8 Location of the first module in each array (example)

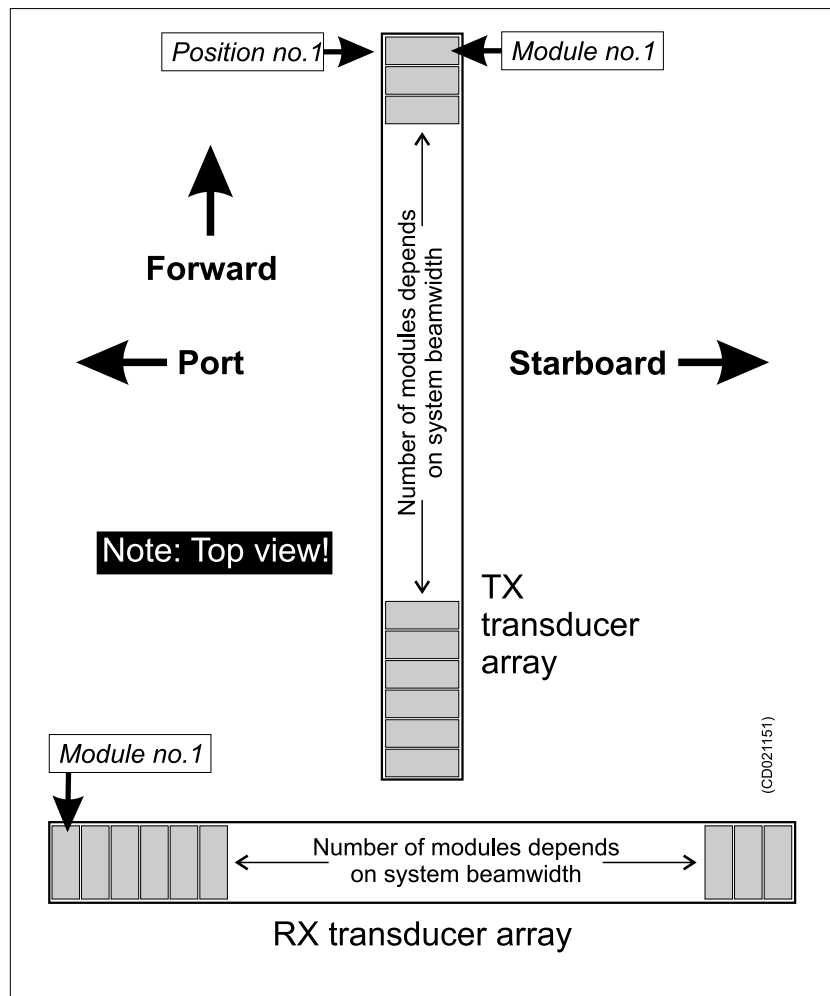

The connections to the Pre-amplifier Unit are made with 25-pin “D-sub” connectors.

Note

During the installation of the receiver array, you must fill in the table below.

In a 1 degree receive system, you will need all the modules listed in the table. With a 2-degree system, you need only the first 8, while the 4-degree system only requires the first 4 modules.

Table 4 Location of Rx modules for 1 degree

| Location of Rx modules | | |
|---------------------------------|----------------------|--------------------------------|
| Physical position / Module type | Module serial number | Socket identifier Preamplifier |
| 1 (port) | | Rx 1 |
| 2 | | Rx 2 |
| 3 | | Rx 3 |
| 4 | | Rx 4 |
| 5 | | Rx 5 |
| 6 | | Rx 6 |
| 7 | | Rx 7 |
| 8 | | Rx 8 |
| 9 | | Rx 9 |
| 10 | | Rx 10 |
| 11 | | Rx 11 |
| 12 | | Rx 12 |
| 13 | | Rx 13 |
| 14 | | Rx 14 |
| 15 | | Rx 15 |
| 16 | | Rx 16 |

Figure 9 Preamplifier Unit

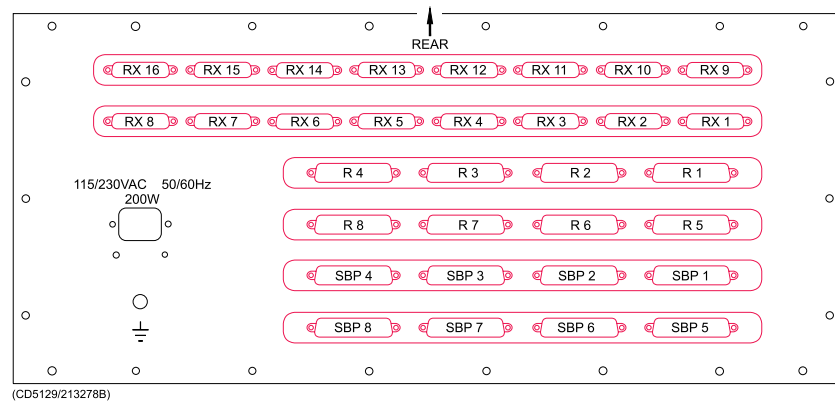

3.4.3 Cables between Tx Junction Box(es) and Transceiver Unit

The signal cabling between the Tx Junction Box(es) and the Transceiver Unit is made up to 24 individual cables. The number of cables depends on the chosen Tx system beamwidth.

For every two transducer cables connected to the Junction Box, one cable is passed on to the Transceiver Unit. The connections on both units are made with 50-pin “D-sub” connectors. The cables and corresponding sockets are identified as listed in the table.

Table 5 Tx Junction Box(es) and Transceiver Unit Cabling

| Tx Junction Box(es) and Transceiver Unit Cabling | | | |
|---|---|-----------------------------------|---|
| Module | Tx Junction Box output socket and cable ID | Socket on Transceiver Unit | Input socket ID on Tx Junction Box |
| 1 | T1/13 | Tx Rio 1 – P3 | Tx 1/25 |
| 2 | | | Tx 2/26 |
| 3 | T2/14 | Tx Rio 1 – P4 | Tx 3/27 |
| 4 | | | Tx 4/28 |
| 5 | T3/15 | Tx Rio 2 – P3 | Tx 5/29 |
| 6 | | | Tx 6/30 |
| 7 | T4/16 | Tx Rio 2 – P4 | Tx 7/31 |
| 8 | | | Tx 8/32 |
| 9 | T5/17 | Tx Rio 3 – P3 | Tx 9/33 |
| 10 | | | Tx 10/34 |
| 11 | T6/18 | Tx Rio 3 – P4 | Tx 11/35 |
| 12 | | | Tx 12/36 |
| 13 | T7/19 | Tx Rio 4 – P3 | Tx 13/37 |
| 14 | | | Tx 14/38 |
| 15 | T8/20 | Tx Rio 4 – P4 | Tx 15/39 |
| 16 | | | Tx 16/402 |
| 17 | T9/21 | Tx Rio 5 – P3 | Tx 17/41 |
| 18 | | | Tx 18/42 |
| 19 | T10/22 | Tx Rio 5 – P4 | Tx 19/43 |
| 20 | | | Tx 20/44 |
| 21 | T11/23 | Tx Rio 6 – P3 | Tx 21/45 |
| 22 | | | Tx 22/46 |
| 23 | T12/24 | Tx Rio 6 – P4 | Tx 23/47 |
| 24 | | | Tx 24/48 |
| Tx Junction Box no. 2 (1 degree only) | | | |
| 25 | T1/13 | Tx Rio 7 – P3 | Tx 1/25 |
| 26 | | | Tx 2/26 |

Table 5 Tx Junction Box(es) and Transceiver Unit Cabling (cont'd.)

| Tx Junction Box(es) and Transceiver Unit Cabling | | | |
|---|---|-----------------------------------|---|
| Module | Tx Junction Box output socket and cable ID | Socket on Transceiver Unit | Input socket ID on Tx Junction Box |
| 27 | T2/14 | Tx Rio 7 – P4 | Tx 3/27 |
| 28 | | | Tx 4/28 |
| 29 | T3/15 | Tx Rio 8 – P3 | Tx 5/29 |
| 30 | | | Tx 6/30 |
| 31 | T4/16 | Tx Rio 8 – P4 | Tx 7/31 |
| 32 | | | Tx 8/32 |
| 33 | T5/17 | Tx Rio 9 – P3 | Tx 9/33 |
| 34 | | | Tx 10/34 |
| 35 | T6/18 | Tx Rio 9 – P4 | Tx 11/35 |
| 36 | | | Tx 12/36 |
| 37 | T7/19 | Tx Rio 10 – P3 | Tx 13/37 |
| 38 | | | Tx 14/38 |
| 39 | T8/20 | Tx Rio 10 – P4 | Tx 15/39 |
| 40 | | | Tx 16/402 |
| 41 | T9/21 | Tx Rio 11 – P3 | Tx 17/41 |
| 42 | | | Tx 18/42 |
| 43 | T10/22 | Tx Rio 11 – P4 | Tx 19/43 |
| 44 | | | Tx 20/44 |
| 45 | T11/23 | Tx Rio 12 – P3 | Tx 21/45 |
| 46 | | | Tx 22/46 |
| 47 | T12/24 | Tx Rio 12 – P4 | Tx 23/47 |
| 48 | | | Tx 24/48 |

Figure 10 Transceiver Unit's rear panel Tx

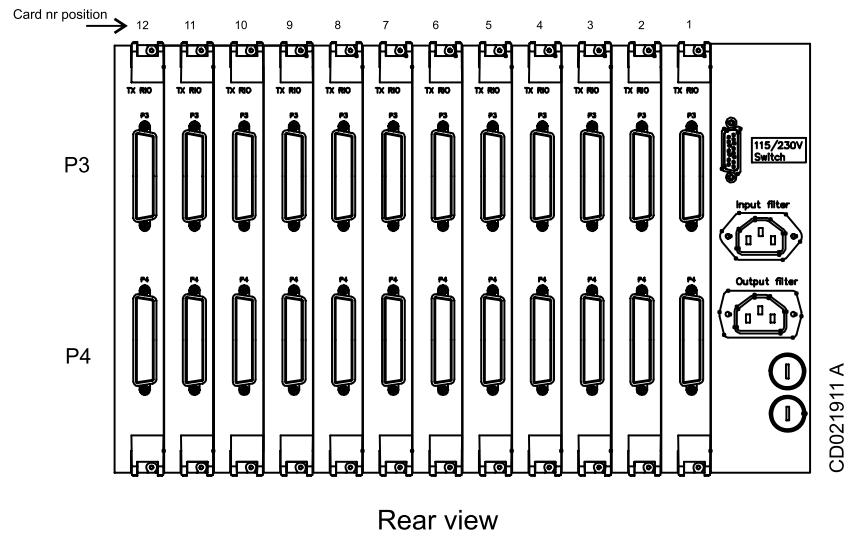
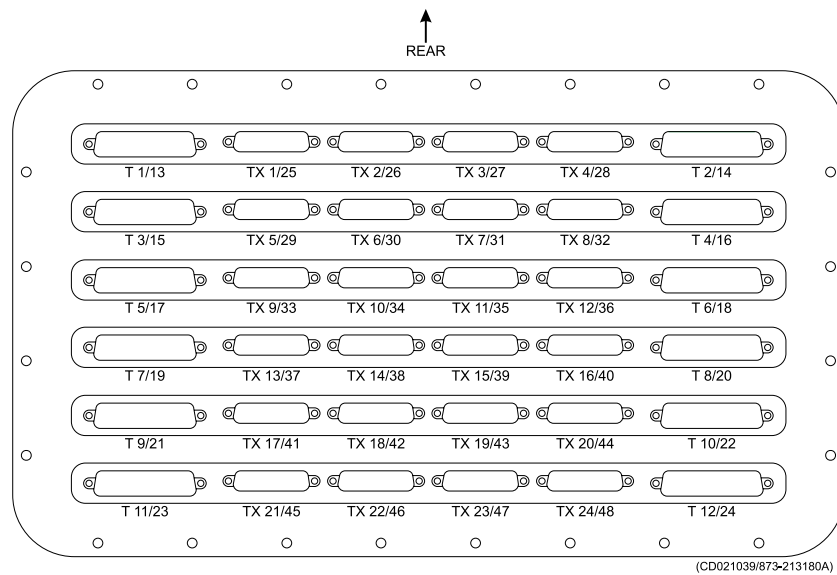

Figure 11 Tx Junction Box



3.4.4 Cables between Preamplifier Unit and Transceiver Unit

The signal cabling between the Preamplifier Unit and the Transceiver Unit is made with 8, 4 or 2 individual cables. The number of cables depends on the chosen Rx system beamwidth.

For every two transducer cables connected to the Preamplifier Unit, one cable is passed on to the Transceiver Unit. The connections on both units are made with 50-pin "D-sub" connectors. The cables and corresponding sockets are identified as listed in the table.

Table 6 Preamplifier Unit and Transceiver Unit Cabling

| Preamplifier Unit to Transceiver Unit Cabling | | | |
|---|--------------------------------------|--|----------------------------|
| Module | Input socket ID on Preamplifier Unit | Preamplifier Unit output socket and cable ID | Socket on Transceiver Unit |
| 1 | Rx 1 | R1 | Rx Rio 1– J3 |
| 2 | Rx 2 | | |
| 3 | Rx 3 | R2 | Rx Rio 1 – J4 |
| 4 | Rx 4 | | |
| 5 | Rx 5 | R3 | Rx Rio 2 – J3 |
| 6 | Rx 6 | | |
| 7 | Rx 7 | R4 | Rx Rio 2 – J4 |
| 8 | Rx 8 | | |
| 9 | Rx 9 | R5 | Rx Rio 3– J3 |
| 10 | Rx 10 | | |
| 11 | Rx 11 | R6 | Rx Rio 3 – J4 |
| 12 | Rx 12 | | |
| 13 | Rx 13 | R7 | Rx Rio 4– J3 |
| 14 | Rx 14 | | |
| 15 | Rx 15 | R8 | Rx Rio 4 – J4 |
| 16 | Rx 16 | | |

In a 1 degree Rx system, all channels from 1 through 16 are used. In a 2 degree system, the first 8 channels are used, while the 4 degree system uses the first 4.

Figure 12 Preamplifier Unit

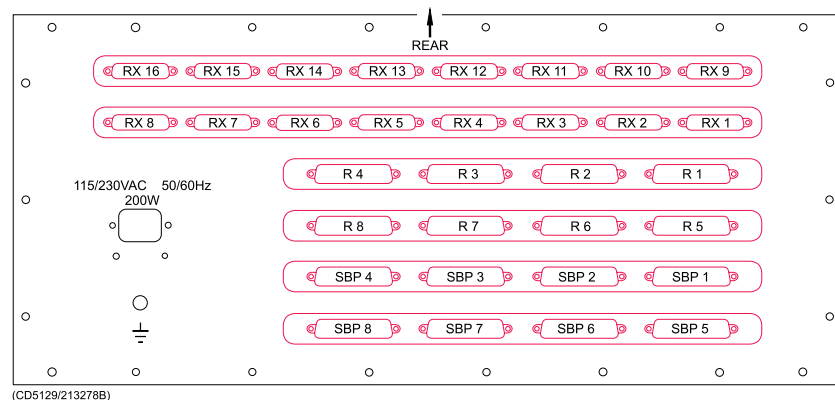

(CD5129/213278B)

Figure 13 EM 122 Transceiver Unit's rear panel Rx

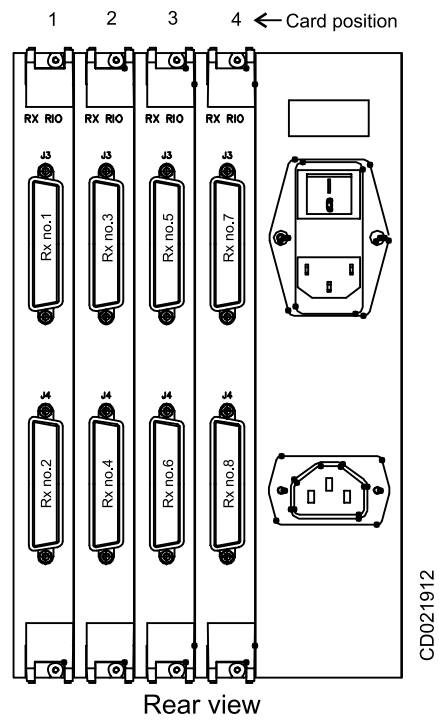

4 OPERATOR STATION

The HWS Hydrographic Work Station is the operator station normally used with the EM 122 Multibeam echo sounder.

This is a basically a PC work station, but it has been specially designed for rugged maritime use, and it is prepared for mounting in a standard 19" rack. In the rack it will require four rack height units. The HWS is by default supplied with at 19" industrial LCD monitor, a keyboard and an optical mouse. The display monitor can be mounted in a 19" rack, however a bracket for table, bulkhead or roof mounting is provided.

Figure 14 HWS Hydrographic Work Station



All components making up the HWS Hydrographic Work Station are standard commercial computer parts.

4.1 HWS overview

The primary task of the HWS Hydrographic Work Station is to safeguard the collected data and to visualize it for quality control. The computer is equipped to handle the heavy processing requirements and the high speed, large volume data storage demands of hydrographic systems. It has been specifically designed as the optimal platform for running the Seafloor Information System (SIS) real-time operating software used on the Kongsberg Maritime EM multibeam echo sounders.

The special features of SIS include real-time:

- Gridding of sounding data
- Filtering of sounding data
- 3-D visualization of sounding data
- Storage and visualization of high resolution backscatter data from the seabed and the water column

The partitioned system disk is by default provided with two operating systems; Linux and Microsoft Windows XP®. During the computer's boot sequence up you can decide which operating system to use. The Seafloor Information System (SIS) software is factory installed and tested on both operating systems.

4.2 Technical description

The primary task of the HWS Hydrographic Work Station is to safeguard the collected data. All data are thus initially stored on a pair of high performance SATA disks. These disks are run in a RAID1 configuration, thus ensuring against loss of data even if one disk should fail. They are mounted in "hot swappable" enclosures, so that the collected data may be transported on the disk.

A DVD recorder is the standard means for permanent archiving of the collected data.

If you wish to use other storage devices or media, the HWS provides USB 2.0, Firewire (IEEE 1394) and SCSI interfaces. Gigabit Ethernet interface is available for transfer of the data to another network computer. For temporary storage data may also be backed up to the system drive.

4.3 HWS circuit boards and modules

The HWS Hydrographic Work Station comprises commercial circuit boards and modules.

5 TRANSCEIVER UNIT

Topics

- *Theory of operation* on page 42
- *Processing and receiver rack* on page 46
- *Transmitter rack* on page 49
- *High Voltage rack* on page 50
- *Circuit board descriptions* on page 53

The EM 122 Transceiver Unit contains all transmit and receive electronics. It comprises three 19" sub-racks contained in a cabinet designed for bulkhead or deck mounting.

- The **Processing and receiver rack** (Processing unit and RX sub-rack) holds the receiver boards, circuit boards for processing, beam forming and communication, with two power supplies
- The **Transmitter rack** (TX sub-rack) holds the transmitter boards and two power supplies
- The **High Voltage** sub-rack holds the caps pcb's and power supplies

All three sub-racks are equipped with high efficiency fans. The filtered air inlet is at the bottom of the Transceiver Unit, and the outlet is at the top.

The Transceiver Unit is mounted on shock and vibration dampers. This chapter provides the following information:

5.1 Theory of operation

Overview

This chapter presents a functional description of the EM 122 Transceiver Unit.

Simplified block diagram

The simplified block diagram for the Transceiver Unit presents the following main functions.

- Processing
- Transmission
- Reception

The commands and parameters from the SIS operator station are sent via the Ethernet connection to the Control processor (CPU) in the TRU.

The CPU contains a DiskOnModule where the software is stored. New releases of the software can be downloaded from the Operator Station.

For control of the transmitters the commands and parameters are interpreted and passed on through an Ethernet interface to the transmitter boards (TX36). The control processor at each TX36 board uses the received parameters to calculate the individual steering of each transmitter. The boards have power amplifiers used for the analog output signals. These signals are sent via the rear I/o module (TX RIO) and a junction box to the TX array. The high voltage is made by a programmable high voltage power supply. The high voltage power supply is controlled through an Ethernet interface. A large capacitor bank is used to store the energy needed for the TX pulses.

The RX array is connected via a preamplifier unit to the TRU. The preamplifier unit contains boards (DP 16) that contains amplifiers and bandpass filters. There are two bandpass filters for each stave, one HF filter for the EM 122 and one LF filter for the optional sub bottom profiler. The preamplified stave data are connected to the RX32 boards in the TRU via the rear I/O modules (RX RIO).

The CPU downloads parameters through an Ethernet interface to the receiver boards (RX32). The RX32 processors control the data acquisition. The stave data are amplified, digitized and bandpass filtered. The stave data are then passed to the BSP 67B board via the backplane.

The BSP 67B boards perform band pass filtering needed for the different TX sectors, and the beam forming of all the receiver beams. The beam data are transferred to the CPU board via the cPCI bus.

The CPU board performs the bottom detection and produces the output datagrams. It also reads the sensor data (time, position, attitude etc.) input from the RS-232 serial lines. The serial lines are connected via the rear I/O board and a serial PMC module mounted on the CPU board. The velocity data is read via a separate Ethernet line. The sound speed profile and the sound speed at transducer depth are received from the operator station. The CPU puts a timestamp on all datagrams. The datagrams are sent via Ethernet to the operator station.

An Ethernet output is available for raw hydrophone data. A raw data logger can be connected to this output.

Figure 15 Transceiver Unit – simplified block diagram

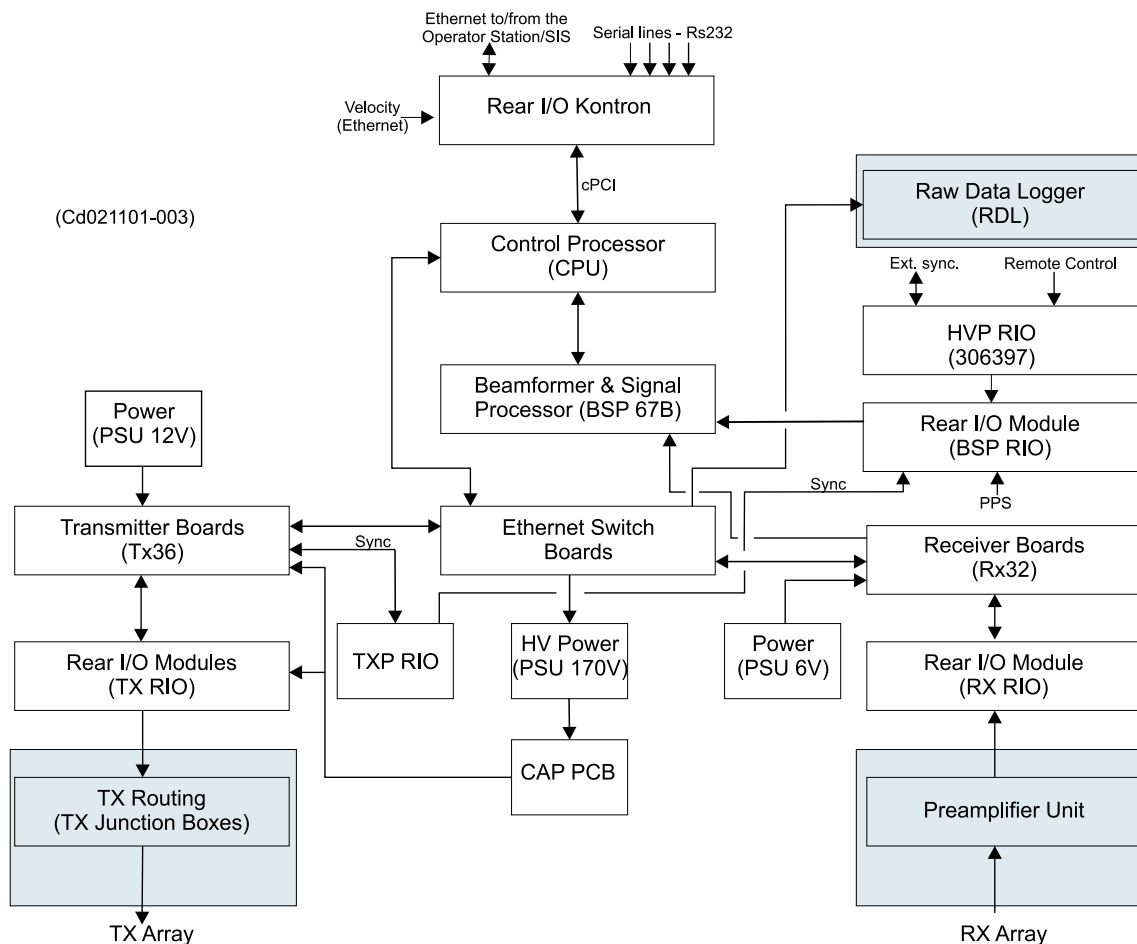

5.1.1 External synchronisation and remote on/off

The RS 232 serial line type RTS and CTS signals are used for external synchronisation. In addition a trig out signal is issued by the TRU.

The signals are available on the plug marked remote on the HVP RIO.

Table 7

| Signal | Level | Function | TRU remote plug |
|--------------------------|--|--|-----------------|
| CTS (TRU input) | H=high= +3 to +15 V L=low = -3 to -15 V | H: Ping command to TRU L: Wait | Pin 8 |
| RTS (TRU output) | H=high= +3 to +15 V L=low = -3 to -15 V | H: TRU is ready for a new ping L: TRU is busy | Pin 7 |
| CTS/RTS gnd | | | Pin 6 |
| Trig out (TRU output) | TTL Level | H: TX is off L: TX is active | Pin 1 |
| Trig gnd | | | Pin 2 |

For cable details, see *Control signals* on page 142

Figure 16 Typical sequence

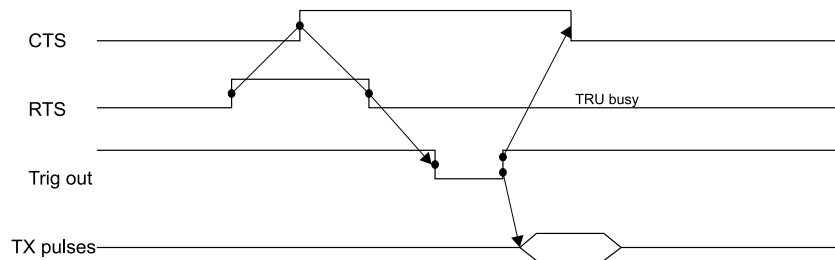

(cd021101-005)

When the TRU is ready for a new ping, RTS is set to H. When the external device is ready for a new ping, CTS shall be changed to H. The CTS must be high for minimum 100 microseconds. The TRU will then change RTS to L (busy), issue a Trig out signal (will be low for 1 millisecond) to indicate the start of the transmit pulses, and then transmit the TX pulses. After the Trig out is received, the external device should turn CTS back to L. When the receive period is finished and the TRU is ready for a new ping, the RTS will be changed to H, and the TRU will wait for a new trigger (a high level on CTS). If CTS is H all the time, or if external sync in the installation menu is switched off, the TRU will ping at its maximum rate.

Remote on/off

The TRU on/off function can be remotely controlled. The TRU is turned on by connecting pin 4 and 5 in the TRU remote plug together.

5.1.2 Clock sync 1 PPS

The 1 PPS (one pulse per second) signal is connected to the coax connector on the BSP RIO board. The BSP RIO is equipped with an optocoupler at this input. The input series resistor is tuned for a TTL signal (Low level <0.6 V, High level > 3.2 V). The falling edge of the signal is used by the TRU to synchronize the internal clock. The 1 PPS signal must be minimum 1 microsecond long.

5.2 Processing and receiver rack

The Processing and receiver rack is the upper sub-rack of the Transceiver Unit. It holds several circuit boards and power supplies. All the units are accessed either from the front or the rear of the rack. The rack contains an 84 HP backplane allowing circuit boards and modules to be inserted from both sides. Two different sizes of 6U boards is used (depths 160 and 220 mm). All circuit boards are supported by guide rails. The rack also contains two high efficiency fan units.

Figure 17 Receiver rack – Rx sub-rack front view

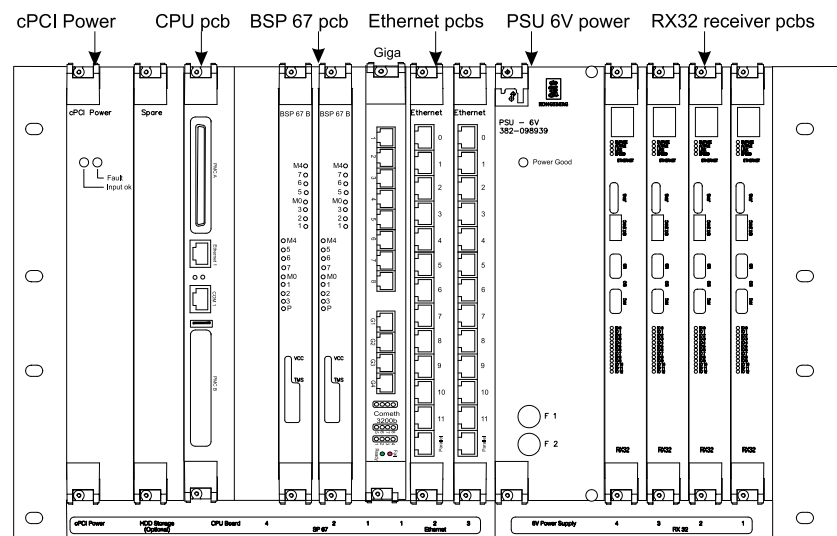

Cd021090-002

The Receiver rack holds the following front mounted circuit boards and modules (from left):

- cPCI Power Supply
- CPU Board
- BSP 67B Boards
- Ethernet Switch Boards
- Power Supply PSU 6V
- RX32 Receiver Boards

Figure 18 Receiver rack – RX sub-rack rear view

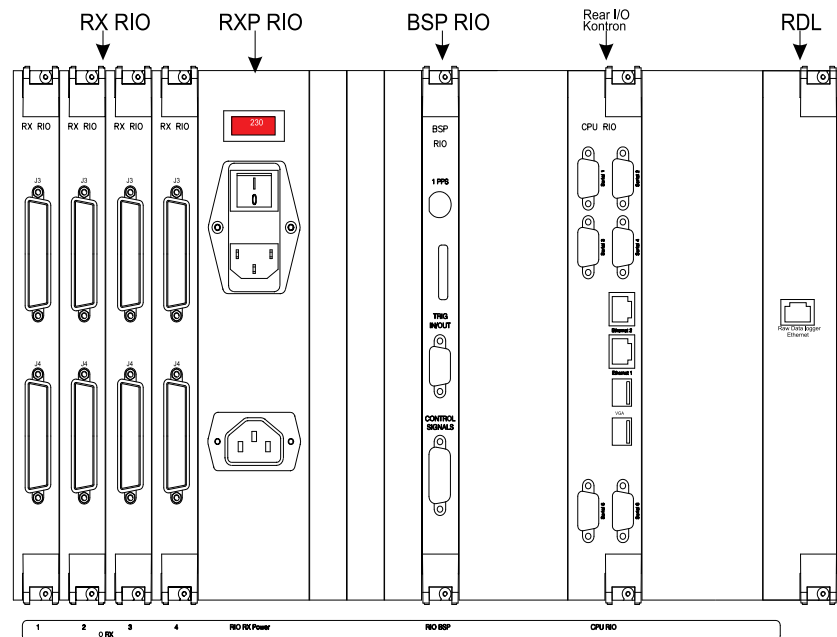

Cd021091-002

The following circuit boards and modules are rear mounted (from left) :

- RX RIO Rear Interface Boards
- RXP RIO Rear Interface Module
- BSP RIO Rear Interface Board
- Rear I/O Kontron Interface Board
- Raw Data Logger (RDL)

The illustrations above display the typical circuit board configuration for a 1 degree receiver system. The number of boards used in the Transceiver Unit is different for each EM 122 model. For the Receiver rack, this is indicated by the table below.

Table 8 RX rack

| RX rack | No. of items | | | | |
|-------------------------------|--------------|-------|-------|-------|-------|
| | 0.5 x 1 | 1 x 1 | 1 x 2 | 2 x 2 | 2 x 4 |
| Circuit boards | | | | | |
| cPCI Power Supply | 1 | 1 | 1 | 1 | 1 |
| CPU Board Kontron | 1 | 1 | 1 | 1 | 1 |
| BSP 67B Board | 2 | 2 | 2 | 2 | 2 |
| Ethernet Switch Board megabit | 2 | 2 | 1 | 1 | 1 |
| Ethernet Switch Board gigabit | 1 | 1 | 1 | 1 | 1 |
| Power Supply PSU 6V | 1 | 1 | 1 | 1 | 1 |

Table 8 RX rack (cont'd.)

| RX rack | No. of items | | | | |
|-------------------------------|---------------------|---|---|---|---|
| RX32 Receiver Board | 4 | 4 | 2 | 2 | 1 |
| RX RIO Rear Interface Board | 4 | 4 | 2 | 2 | 1 |
| RXP RIO Rear Interface Module | 1 | 1 | 1 | 1 | 1 |
| BSP RIO Rear Interface Board | 1 | 1 | 1 | 1 | 1 |
| Rear I/O Interface Board | 1 | 1 | 1 | 1 | 1 |
| Raw Data Logger (RDL) | 1 | 1 | 1 | 1 | 1 |

5.3 Transmitter rack

The Transmitter rack is the lower sub-rack of the Transceiver Unit. It holds several circuit boards and power supplies. All the units are accessed either from the front or the rear of the rack. The Transmitter rack contains an 84 HP backplane allowing circuit boards and modules to be inserted from both sides. The front mounted modules are all 6U deep (220 mm) and the rear modules have a standard depth of 80 mm. All circuit boards are supported by guide rails. The rack also contains a high efficiency fan unit.

Figure 19 Transmitter rack – front view

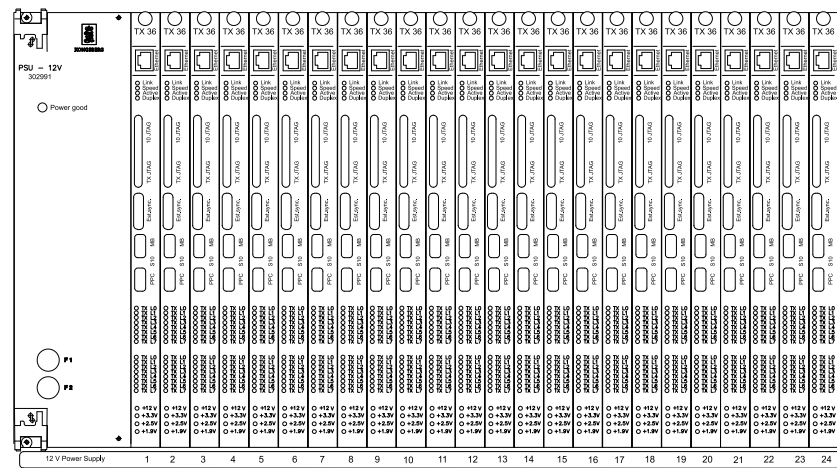

CD021091-003

The Transmitter rack holds the following front mounted circuit boards and modules (from left):

- Power Supply PSU 12V
- TX 36 Transmitter Boards

Figure 20 Transmitter rack – rear view

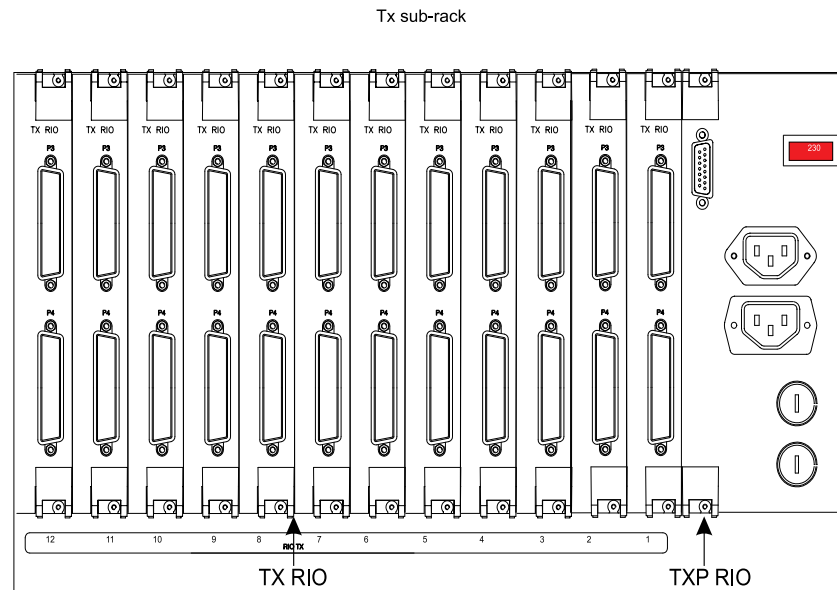

(cd021096)

The following circuit boards and modules are rear mounted (from left) :

- TX RIO Rear Interface Board
- TX Power RIO Rear Interface Module

The illustrations above display the typical circuit board configuration for a 0.5 or 1 degree Tx system. The number of boards used in the Transceiver Unit is different for each EM 122 model. For the Transmitter rack, this is indicated by the table below.

Table 9 TX rack

| TX rack | No. of items | | | | |
|------------------------------|--------------|-------|-------|-------|-------|
| | 0.5 x 1 | 1 x 1 | 1 x 2 | 2 x 2 | 2 x 4 |
| Circuit boards | | | | | |
| TX36 Transmitter Board | 24 | 24 | 24 | 12 | 12 |
| Power Supply PSU 12V | 1 | 1 | 1 | 1 | 1 |
| TXP RIO Rear Interface Board | 1 | 1 | 1 | 1 | 1 |
| TX RIO Rear Interface Board | 12 | 12 | 12 | 6 | 6 |

5.4 High Voltage rack

The High Voltage (HV) rack is the lowest sub-rack in the Transceiver Unit. It holds several capacitor modules (cap pcb) and a power supply. All the units are accessed either from the front or the rear of the rack. The high voltage rack contains an 84 HP backplane allowing power units and capacitance modules to

be inserted from both sides. The front mounted modules are all 6U deep (220 mm) and the rear modules have a standard depth of 80 mm. All circuit boards are supported by guide rails. The rack also contains a high efficiency fan unit.

Figure 21 High Voltage rack – front view

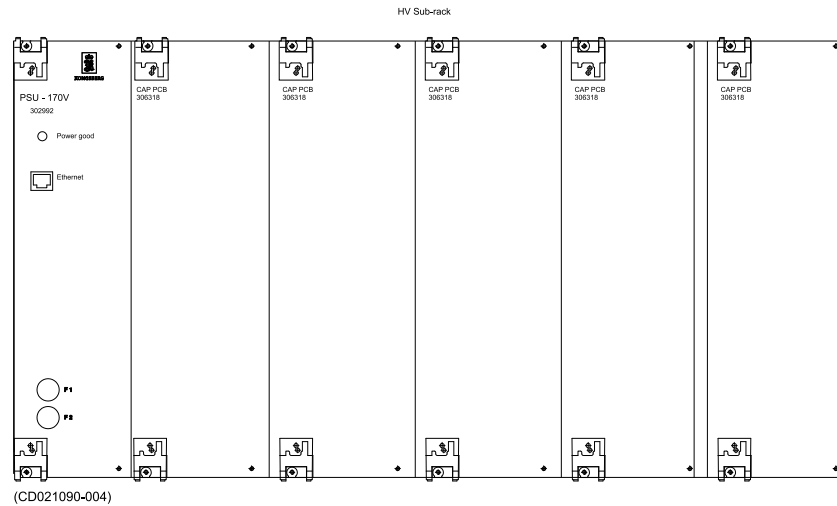

The HV rack holds the following front mounted circuit boards and modules (from left):

- 170 V Power Supply
- Cap pcbs

The illustrations above display the typical circuit board configuration for a 1 x 1 degree system.

Figure 22 High Voltage rack – rear view

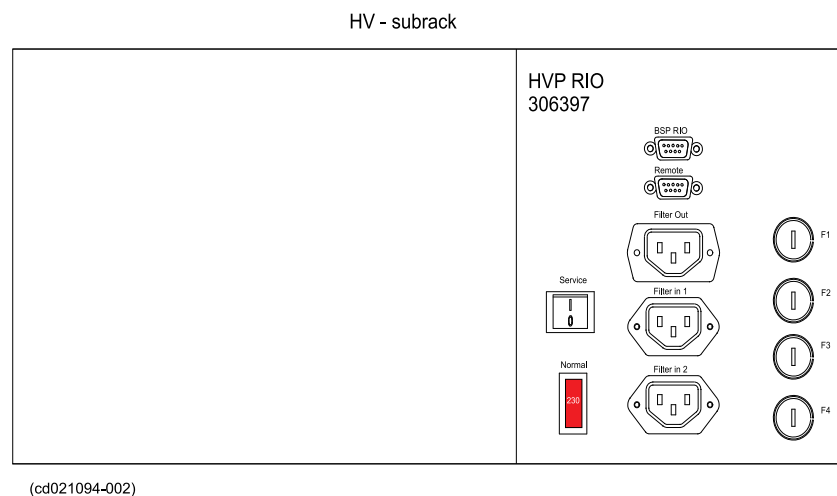

The HVP RIO modules is the only unit connected from the rear.

The following circuit boards and modules are rear mounted (from left) :

- Cap pcb

The number of boards used in the HV rack depends on TX array size, as indicated by the table below.

Table 10 HV rack – Capacitor

| HV rack (Capacitor) | No. of items | | | | |
|----------------------------|---------------------|-------|-------|-------|-------|
| Circuit boards | 0.5 x 1 | 1 x 1 | 1 x 2 | 2 x 2 | 2 x 4 |
| 170 V Power Supply | 1 | 1 | 1 | 1 | 1 |
| CAP PCB | 5 | 5 | 5 | 3 | 3 |
| HVP RIO 306397 | 1 | 1 | 1 | 1 | 1 |

5.5 Circuit board descriptions

In the following all the circuit boards and modules in the EM 122 Transceiver Unit are described. All facilities useful for maintenance personnel are provided.

5.5.1 cPCI Power Supply

Purpose and description

This is a standard 500 W cPCI Power Supply. Its main purpose is to supply DC output to the CPU, BSP 67B, RX32 and Ethernet Switch circuit boards.

Figure 23 Power One



Key features

- PICMG 2.11 compatible
- AC input
- Industry standard
- Power factor corrected
- Active current share
- International safety approvals

Specifications

Input:

- Input voltage: 90 to 264 Vac, 47 to 63 Hz
- Maximum input current: 7.1 A /90 Volt
- Inrush current: 30 A at 120 Vac, 20 A at 240 Vac
- Power factor: 0.95

Output:

- Output voltage and current ratings

Table 11

| Output voltage (Vdc) | Maximum output current (A) |
|----------------------|----------------------------|
| 3.3 | 60.0 |
| 5.0 | 50.0 |
| 12.0 | 12.0 |
| -12.0 | 4.0 |

- Line regulation: $\pm 10\text{mV}$
- Load regulation: $\pm 10\text{mV}$

General

Efficiency: 80% minimum at 110 Vac

Isolation: Input to ground 500 Vac, input to output 1500 Vac

Facilities

There are two front panel LEDs

LEDs:

- Green: Power good
- Amber: Power fail

External connections

None.

5.5.2 CPU Board with PMC Module

Purpose and description

The Kontron CP6011 cPCI Single Board Computer is a fully IBM-AT compatible stand-alone PC. It is used by the Transceiver Unit as the Central Processing Unit (CPU). The TPMC866 is a standard single-width 32 bit PMC module. It has eight channels of high performance RS-232 serial ports with front I/O and back I/O. It is mounted on the CPU Board.

Figure 24 CPU Board

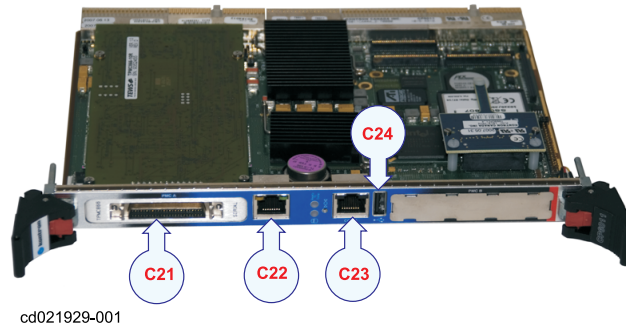

Key features

- Intel® Pentium M processor, 1.8 GHz
- FlashDrive, 512 Mb
- PCI Mezzanine Card (PMC) Interface

Specifications

Input

- Supply voltages: +3.3Vdc, +5 Vdc, +12 Vdc, -12 Vdc
- Current (max): 6.1 A at 3.3 Vdc, 5.6 A at 5 Vdc, 0.3 A at 12 Vdc, <10 mA at -12

Vdc

- Power consumption: 43 W max

Capability

- DRAM: 512 MB SDRAM with ECC. Running at 200 MHz
- Chipset: Intel E7501 and Intel ICH3-S south bridge

- CMOS RAM: 114 byte non-volatile RTC, MC146818 compatible
- RTC with on-board Lithium battery

Facilities

There are two front panel LEDs

LEDs

- Blue: Hot swap Green: Power OK
- Green: Flash disk activity

External connections

The following cables can be connected to the circuit board

- **C21 - PMC I/O Interface (TPMC866–10) – not used**
The TPMC866–10 cable is equipped with a 50-pin connector.

- **C22 - Ethernet**

The Ethernet cables are equipped with standard RJ-45 connectors. The CPU board has one Ethernet port (ETH1) in the front.

C22 connects to ETH1 for communication with one of the Ethernet Switch Boards. The cable C22 is provided by the manufacturer, and it is a part of the internal cabling

For cable details, see *Ethernet cable with RJ45* on page 144.

- **C23 - Serial line (COM1) — not used**

This is a serial line terminated in a RJ 45 connector. COM1 is software selectable for RS-232 or RS-422/485 operation.

- **C24 - USB — not used**

The USB cable is equipped with a standard USB2 connector. One USB channel is available at the front panel of the CPU board. This cable is normally not used.

5.5.3 Kontron CP 6011 pentium CPU BOARD

Bios settings

Date

Time

- Legacy diskette A: Disabled
- Primary Master: Auto Shown as 261 MB
- Primary Slave: None
- Secondary Master: None
- Secondary Slave: None
- POST Errors Disabled
- System Memory 624 KB
- Extended Memory 511 MB

Advanced

Boot Settings Configuration

- Installed O/S Other
- Enable ACPI No
- Reset Configuration Data No
- Boot-time Diagnostic Screen Enabled
- Extended Memory Testing None
- Summary Screen Delay None
- Save CMOS in FLASH Enabled
- Retry Boot Sequence Disabled
- PS/2 Mouse Disabled
- SMART Device Monitoring Disabled
- Floppy Check Disabled

PCI Configuration – On-board Ethernet Controller

- On-board Ethernet Controller 1 Enabled
 - Option ROM Scan Disabled
- On-board Ethernet Controller 2 Enabled
 - Option ROM Scan Disabled
- On-board Ethernet Controller 3 Enabled
 - Option ROM Scan Disabled

PCI Configuration – On-board PMC Expansion

- On-board PMC A Expansion Slot
 - Option ROM Scan Enabled
 - Latency Timer Default
- On-board PMC B Expansion Slot
 - Option ROM Scan Enabled
 - Latency Timer Default

PCI Configuration – PCI Performance Settings

- PCI Cache Line Size 16
- On-board HB8 PCI-X Bridge Settings
 - Force 64 bit Control Both
 - Smart Prefetch Mechanism Enabled
 - Smart Prefetch Timeout 256 PCICLK
 - Prefetch scheme Aggressive
 - PCIX Pimary Initial Prefetch Count 8
 - PCI Sec. Initial Prefetch count 8
 - PCI Sec. Incremental Prefetch count None
 - PCI Sec. Maximum Prefetch count 32
- Default Primary Video Adapter On-board
- Delay before PCI Initialization 0
- IDE - Device 31, Function 1 Enabled
- Legacy USB Support Enabled

On-board Device Configuration

- Serial port A Enabled
 - Base I/O address 3F8
 - Interrupt IRQ 4
- Serial port B Enabled
 - Base I/O address 2F8
 - Interrupt IRQ 3
 - Mode RS-232
- Floppy Disk Controller Disabled

Advanced Chipset Control

- ECC Config ECC

Console Redirection

- Console Redirection Disabled
- N/A

Advanced Processor Options

- Speed Step Support POM

Monitoring**Intelligent System Monitor**

- Interrupt Generation Disabled
- Hardware Monitor Temperature **Read Temperature**
- Hardware Monitor Voltage Inputs **Read Voltages**

Control Temperature Events

- CPU Temperature Interrupt Disabled
- N/A

Control Voltage Events

- XXXX Interrupt **Disable All**

IPMI System Management

- N/A
- IDE Activity LED IDE Activity
- Watchdog After POST Disabled
- FPGA IRQ Disabled
- Automatic TCC Disabled
- Delay Prior to enabling the TCC N/A

Boot

- CD-ROM Drive
- Hard Drive
- Removable Devices

5.5.4 BSP 67B Board

Purpose and description

The Beamforming & Signal Processing Board (BSP67B) is a double cPCI board. The BSP67B Board is used by the Transceiver Unit for beamforming and signal processing purposes. The processing power in the BSP67B Board is based on sixteen Texas C6713B digital signal processors (DSP) working in parallel.

Figure 25 BSP 67B Board

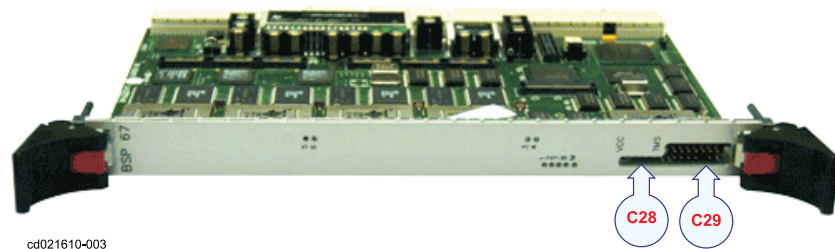

Specifications

Power consumption: 40W at 3.3Vdc/5Vdc

Facilities

LEDs

There is one LED for each of the sixteen DSPs. The LEDs are marked M4, 5, 6, 7, M0, 1, 2, 3 on both Base board and Mezzanine Board. The upper row is for Mezzanine Board. When BSP67B is loaded, the LEDs will normally flash with a frequency of 1 Hz. LEDs marked B and P are for test purpose only.

External connections

The following cables can be connected to the circuit board

- **C28 - VCC to TMS** For FPGA programming and test purpose

This cable is connected to the VCC slot to provide a JTAG interface to the FPGA modules on the BSP 67B board. The signals of the VCC slot are available at a 36-pin single line header.

Note

This interface is only to be used by Kongsberg Maritime personnel.

- **C29 - TMS** For test purposes only

This cable is connected to the TMS Emulator slot for programming and development purposes. The signals of the TMS slot are available at a 14-pin double line header.

Note _____

This interface is only to be used by Kongsberg Maritime personnel.

5.5.5 Ethernet Switch Board – Gigabit

Purpose and description

This is a 12 channel cPCI Ethernet Switch Board. It is used to interconnect the RX32 Receiver Boards and TX36 Transmitter Boards with the CPU Board.

Figure 26 Ethernet Switch Board

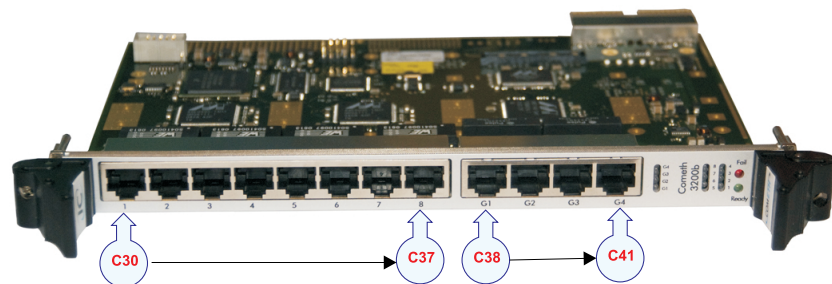

CD021098-006

Key features

- 8 ports of fast and 4 Giga Ethernet ports, auto-negotiating, front panel
- Full wire speed layer 2/3 switching on all ports
- Auto address learning
- Auto address aging

Specifications

- Power consumption: 3.3 Vdc or 5 Vdc Power supply up to 18 Watts according to the configuration
- 1 – 8 Ethernet ports: 10/100TX
- G1 – G4 Ethernet ports: 10/100/1000BT
- Port routing: RJ-45 10/100/1000 BaseTX (at front)

Facilities

Front panel LEDs

- Power supply and CPU Status
- Switched ports : activity/link

External connections: The following cables can be connected to the circuit board

- **C30 to C37 – 100 Megabit Ethernet ports**

The Ethernet cables are equipped with standard RJ-45 connectors. The Ethernet board has 12 Ethernet ports. 8 fast ports * 10/100TX (FB) and 4 giga ports * 10/100/1000BT (FB)

The Ethernet interface of each RX32 receiver board and some of the TX36 transmitter boards are connected to fast ports from C30 to C37.

C31 to C34 – Here must RX32 be connected.

One Ethernet port must be used to communicate with the CPU board and HV power.

These cables are provided by the manufacturer. Each cable is cut to a suitable length for connection to dedicated ports. The cable ends are labelled accordingly.

For cable details see *Ethernet cable with RJ45* on page 144.

- **C38 to C41 – Giga ports (C40 – Connection to Raw data Logger)**

The output data to the Raw data logger must be connected to port number C40.

These cables are provided by the manufacturer. Each cable is cut to a suitable length for connection to dedicated ports. The cable ends are labelled accordingly.

For cable details see *Ethernet cable with RJ45* on page 144.

Connection for Gigabit card – 0.5x1, 1x1 and 1x2 degree system

- **C30** – 1 connected to CPU/LAN label ETH1–1
- **C31** – 2 connected to RX32 – 1 / label ETH1–2
- **C32** – 3 connected to RX32 – 2 / label ETH1–3
- **C33** – 4 connected to RX32 – 3 / label ETH1–4
Not used on 1x2 degree system
- **C34** – 5 connected to RX32 – 4 / label ETH1–5
Not used on 1x2 degree system
- **C35** – 6 connected to TX36 – 1 / label ETH1–6
- **C36** – 7 connected to TX36 – 2 / label ETH1–7
- **C37** – 8 connected to TX36 – 3 / label ETH1–8
- **C38** – G1 connected to TX36 – 4 / label ETH1–G1
- **C39** – G2 connected to TX36 – 5 / label ETH1–G2
- **C40** – G3 connected to RDL / label ETH1–G3
- **C41** – G4 connected to ETH2–10 / label ETH1–G4

5.5.6 Ethernet Switch Board – Megabit

Purpose and description

This is a 12 channel cPCI Ethernet Switch Board. It is used to interconnect the RX32 Receiver Boards and TX36 Transmitter Boards with the CPU Board.

Figure 27 Ethernet Switch Board with arrows

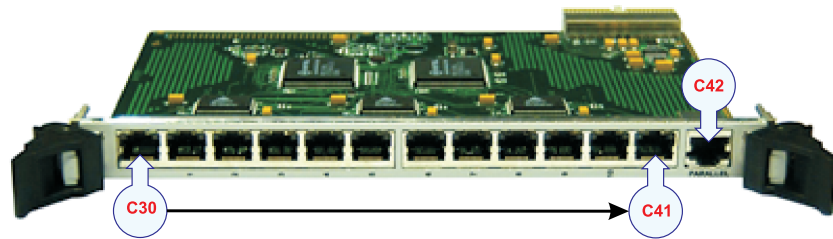

Key features

- 12 ports of 10/100BaseTX, auto-negotiating, front panel
- Full wire speed layer 2 switching on all ports
- 1k MAC address table
- Auto address learning
- Auto address aging

Specifications

Power consumption: 1.2 A at 3.3 Vdc

Ports: 10/100 BaseTX: 12

Parallel port: 1

Port routing: RJ-45 10/100 BaseTX (at front)

Facilities

LEDs: None

External connections: The following cables can be connected to the circuit board

- **C30 to C41 - Ethernet ports**

The Ethernet cables are equipped with standard RJ-45 connectors. The Ethernet board has 12 Ethernet ports (0 to 11). The Ethernet interface on the TX36 transmitter board must be connected to an Ethernet board.

These cables are provided by the manufacturer. Each cable is cut to a suitable length for connection to dedicated ports. The cable ends are labelled accordingly.

- **C42 - Parallel port – not used**

The parallel port has a standard Ethernet RJ-45 interface. This interface is not used.

Connection for Megabit card no 2 – 0.5x1, 1x1 and 1x2 degree system

- **C30** – 0 connected to TX36 – 6 / label ETH2–0
- **C31** – 1 connected to TX36 – 7 / label ETH2–1
- **C32** – 2 connected to TX36 – 8 / label ETH2–2
- **C33** – 3 connected to TX36 – 9 / label ETH2–3
- **C34** – 4 connected to TX36 – 10 / label ETH2–4
- **C35** – 5 connected to TX36 – 11 / label ETH2–5
- **C36** – 6 connected to TX36 – 12 / label ETH2–6
- **C37** – 7 connected to TX36 – 13 / label ETH2–7
- **C38** – 8 connected to TX36 – 14 / label ETH2–8
- **C39** – 9 connected to TX36 – 15 / label ETH2–9
- **C40** – 10 connected from ETH1–G4 / label ETH2–10
- **C41** – 11 connected to ETH3–10 / label ETH2–11
- **C42** – not in use

Connection for Megabit card no 3 – 0.5x1, 1x1 and 1x2 degree system

- **C30** – 0 connected to TX36 – 16 / label ETH3–0
- **C31** – 1 connected to TX36 – 17 / label ETH3–1
- **C32** – 2 connected to TX36 – 18 / label ETH3–2
- **C33** – 3 connected to TX36 – 19 / label ETH3–3
- **C34** – 4 connected to TX36 – 20 / label ETH3–4
- **C35** – 5 connected to TX36 – 21 / label ETH3–5
- **C36** – 6 connected to TX36 – 22 / label ETH3–6
- **C37** – 7 connected to TX36 – 23 / label ETH3–7
- **C38** – 8 connected to TX36 – 24 / label ETH3–8
- **C39** – 9 connected to HV power / label ETH3–9
- **C40** – 10 connected from ETH3–10 / label ETH3–10
- **C41** – not in use
- **C42** – not in use

5.5.7 Power Supply PSU 6V

Purpose and description

This is a 6 V / 25 A power supply. It is used to supply DC power to the analog part of the RX32 Receiver Boards.

Figure 28 Power Supply PSU 6V



Specifications

Input:

- Maximum operating range: 90 to 264 Vac
- Nominal input voltage range: 110 to 240 Vac, 47 to 64 Hz
- Inrush current: < 10 A in 10 ms
- Power factor: > 90 %

Output:

- Output voltage: 6 Vdc \pm 2 %
- Switching frequency: 166.667 kHz
- Output current limit: < 28 A
- Minimum load: 1 A
- Maximum load: 25 A continuously
- Line regulation: < \pm 0.2 %
- Load regulation: < \pm 1 %
- Ripple and noise: < 60 mV (peak-to-peak)

Facilities

LEDs:

- Green: Power good

External connections:

None.

5.5.8 RX32 receiver board

The RX32 Receiver Board is designed for reception and processing of transducer data.

Figure 29 RX32 Receiver Board

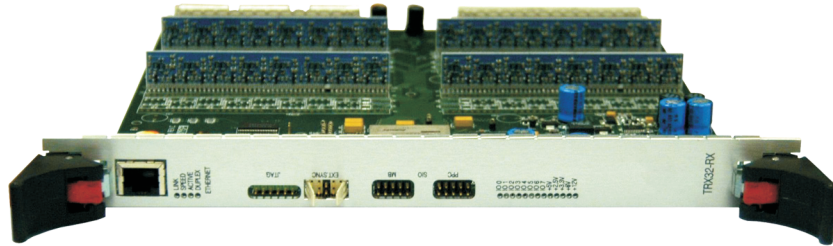

Note

Circuit boards are delicate items. They may work year after year in an advanced product, but then fail due to a small spark of static electricity. For this reason, it is very important that they are properly handled and protected during handling.

- Power supplies
- Network FPGA and surrounding components
- Receiver part, 32 identical FPA receiver channels

The RX32 Receiver Board includes 32 independent FPA (Floating Point Amplifier) receivers. The operating frequency is programmable within the range 10 to 500 kHz. All command input and sample data output are communicated via a 100 Mbit/s Ethernet interface.

The receivers generate band pass filtered complex sample data at a programmable output rate. The sample values from all 32 receivers can be output via the Ethernet interface without further processing. Onboard power circuitry generates all internal voltages from a +12 Vdc and a +6 Vdc input.

The receiver is based upon the FPA ASIC (Application-Specific Integrated Circuit). The FPA ASIC is a complete one-channel frontend, including all the signal-processing from the transducer input to a digital serial interface to a signal processor. The RX data is collected by a FPGA (Field Programmable Gate Array).

A 4 bit nibble link in the backplane is used to transfer the sample values from the RX32 board to the BSP67B board(s).

Figure 30 RX32 simplified block diagram

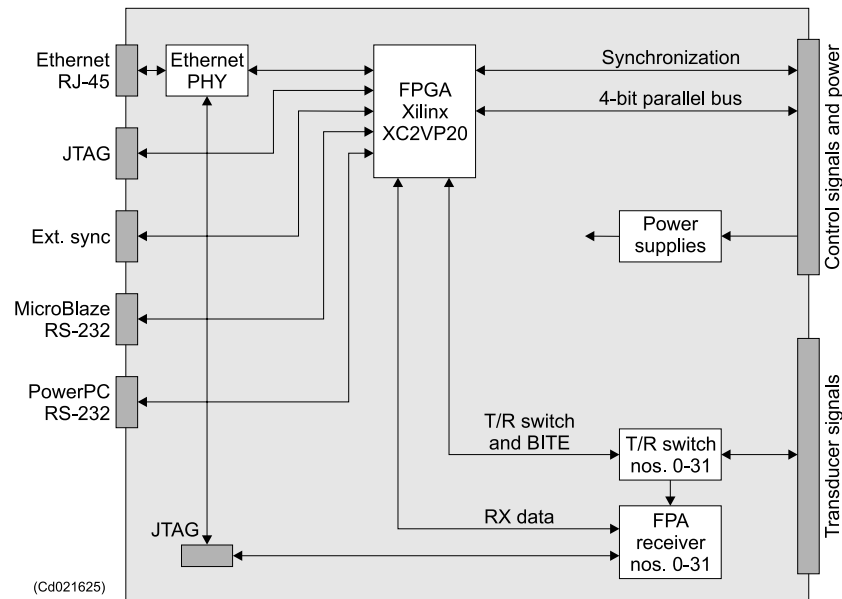

Technical specifications

These are the main technical specifications for the RX32 Receiver circuit board. Please note that technical specifications can be altered without prior warning.

Power supply specifications

- Main supply voltages: +6 V, +12 V
- Current consumption: 2.5 A (6 V), 0.75 A (12 V)

Transducer interface

- Number of channels: 32
- Receiver input impedance: 75 ohms or 1000 ohms, software selectable
- Transducer connections: Differential
- Transducer connector: 96-pin Euro connector

Interface specifications

- Ethernet: 10/100Mb/s
- Nibble Bus: Special 4-bit interface
- ID0 to ID4: Active high identification bits 0 to 4 (maximum 32 board addresses)
- ID5 to ID7: Active high identification bits 5 to 7 (maximum 8 rack addresses)
- CLK20MHZ: Differential system master clock, 20 MHz
- RESET: Differential active low reset, synchronized to negative edge of CLK20MHZ

- MASTER: Active low, enables master signal source
- PS_SYNC: Switching power supply synchronization

Receiver specifications

- Input termination: Fully differential input
- Input impedance: Matched to transducer (75 ohms) or high impedance (1 kohm)
- Frequency range: 10 to 500 kHz
- Low pass filter: Anti-aliasing, 62.5, 125, 250 and 500 kHz
- Gain: 0 to 90 dB in 6 dB steps
- Noise figure:
 - Impedance matching: 5 dB
 - High impedance: 2 dB
- Sampling: Simultaneous sampling of all channels, 2 MHz
- Automatic Gain Selection (AGS): Implemented for each channel, selects optimum gain setting to make best use of analogue to digital input range
- Analogue to digital conversion: 12 bit resolution
- Dynamic range: > 140 dB
- Signal processing: Digital demodulation, filtering and decimation (ratio 7 – 256)

The receiver technology is based on the **Floating Point Amplifier (FPA) ASIC**. Eight of these ASICs in die form are used on the eight channel **FPA8** hybrid circuit. This hybrid circuit also includes necessary surrounding components, such as power supply decoupling.

Facilities

LEDs

- Ethernet: Four LEDs display Ethernet operating mode and activity
- LINK: The connection to the external device is OK (green)
- SPEED: The detected bit rate is 100 Mbit/s (yellow)
- ACTIVITY: Flashing light indicates transmit and receive activity (green)
- DUPLEX: The interface operates in full duplex mode (yellow)

I/O

- I/O: Eight yellow LEDs display processor activity and error conditions.

- IO 0: The PowerPC embedded program broadcasts a BOOTP/DHCP (Boot Strap Protocol / Dynamic Host Configuration Protocol) request via the Ethernet interface.
- IO 1: A BOOTP/DHCP reply message has been received from an external boot server.
- IO 2: The PowerPC sends a TFTP (Trivial File Transfer Protocol) request to the boot server asking for its application program.
- IO 3: The PowerPC embedded program is up and running. The PowerPC embedded program is included in the FPGA firmware as initialized block RAM.
- IO 4: This LED flashes when the receivers are running and generating sample data. The flash speed is proportional to the receiver decimation clock.
- IO 5: This LED is reserved for product maintenance tasks.
- IO 6: This LED flashes every time TXENABLE goes active.
- IO 7: The MicroBlaze embedded program is up and running. The MicroBlaze embedded program is included in the FPGA firmware as initialized block RAM.

Power

- Power: Five green LEDs indicate that the internal supply voltages are OK.
- +5 V
- +2.5 V
- +3.3 V
- +6 V
- +12 V

Figure 31 RX32 Receiver Board with arrows

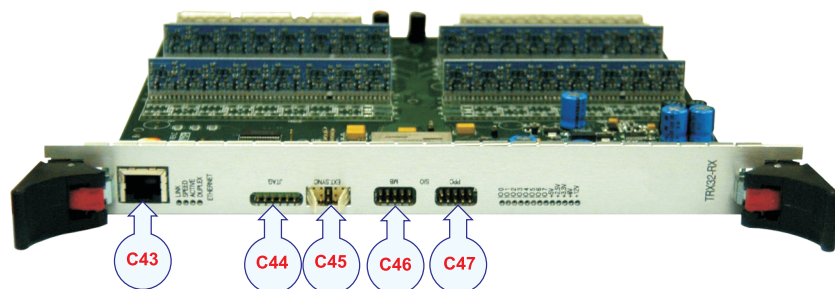

External connections**• C43 - Connected to Ethernet switch board**

The Ethernet cable is equipped with a standard RJ-45 connector. The Ethernet interface of the RX32 receiver board must be connected to an Ethernet switch board. This interface is used for all command input and sample data output. This is normally the only cable connected to the RX32 receiver board. It is provided by the manufacturer. *Ethernet cable with RJ45* on page 144.

• C44 - JTAG / For internal use only

This cable is connected to the JTAG slot to provide a JTAG interface to the FGPA modules on the RX32 receiver board. The signals of the JTAG slot are available at a 6-pin single line header.

Note _____

This interface is only to be used by Kongsberg Maritime personnel.

• C45 - External synchronization (EXT SYNC) / For internal use only

This cable is connected to the EXT SYNC slot for accurate transmit synchronization with external equipment. The signals of the EXT SYNC slot are available at a 10-pin double line header.

Note _____

This interface is only to be used by Kongsberg Maritime personnel.

• C46 - MicroBlaze (MB) / For internal use only

This cable is connected to the MB slot for debugging the MicroBlaze (FPGA soft-core processor) program software. The signals of the MB slot are available at a 10-pin double line header.

Note _____

This interface is only to be used by Kongsberg Maritime personnel.

- **C47 - PowerPC (PPC) / For internal use only**

This cable is connected to the PPC slot for debugging the PowerPC (FPGA hard-core processor) program software. The signals of the PPC slot are available at a 10-pin double line header.

Note _____

This interface is only to be used by Kongsberg Maritime personnel.

5.5.9 RX RIO – Rear Interface Board

Purpose and description

This is the rear I/O module for the RX32 Receiver Board. It connects the 32 receiver channels to the two 50-pin connectors and each Rx RIO board connects to the preamplifier cables. The signals are low level ac signals, $< 5\text{ V}$ and $< 0.1\text{ A}$.

Figure 32 RX RIO

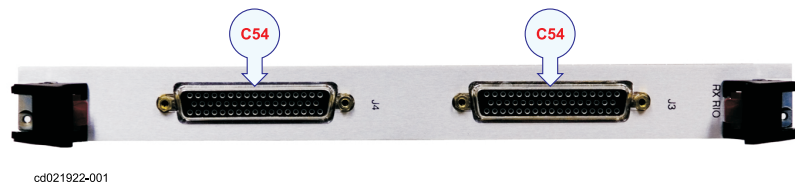

Facilities

LEDs

- None

External connections

- **C54 - Preamplifier interconnection cables**

This is a RX transducer cable terminated in a 50-pin D-sub connector.

Each RX RIO board connects to the preamplifier unit.

For cable details see *Rx transducer cable from Preamplifier to TRU* on page 156.

5.5.10 RXP RIO – Rear Interface Board

Purpose and description

This is a rear I/O module with AC input filter. It connects the 115/230 Vac input to the backplane. One AC output plug with filter is also available for the possibility to connect an extra fan module (not used).

Figure 33 RXP RIO

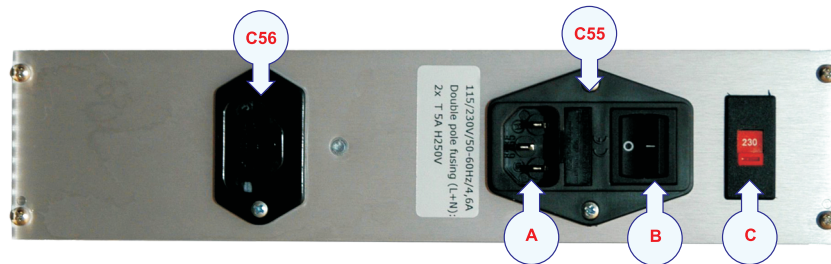

Facilities

LEDs

- None

External connections

- **C55 – AC power**

A AC power

B On/off

C Switch – 115/230 V

These are 115/230 Vac AC mains cables. Cable C55 must be equipped with a 3-pin IEC female socket and C56 in a male equivalent.

C55 connects to the TXP RIO board.

The cable C55 is provided by the manufacturer.

For cable details, see *Standard AC power cable* on page 143

- **C56 – AC power**

normally not used

5.5.11 BSP RIO – Rear Interface Board

Purpose and description

This is the rear I/O module for the master BSP. It holds control signals from the TX sub-rack (power sync), external trig interface (TX pulse output, RX ready output, trig input) and 1PPS input.

Figure 34 BSP RIO



Facilities

LEDs:

- None

External connections:

The following cables are connected to the circuit board

- **C57 - 1PPS from external sensor**

This is a standard coaxial cable with a BNC plug. It is used to provide a 1PPS timing signal.

For more information about clock synchronisation, see *Clock sync 1 PPS* on page 45

For cable details, see *Generic coax cable* on page 138.

- **C58 - Trigger in/out to HVP RIO**

This cable is equipped with a standard 9-pin D-sub connector. The interface is used to synchronize the echo sounder's transmissions with other acoustic instruments.

This interface is connected to HVP-RIO C80 installed by the manufacture.

For cable details, see *Trigger in/out* on page 140.

- **C59 - Control signals to TXP RIO**

This cable is connected to TXP RIO (C71) and it is installed by the manufacturer.

5.5.12 Rear I/O Interface Board (Kontron)

Purpose and description

This is the rear I/O module for external sensors. For this purpose, it is equipped with four serial lines and two Gbit ethernet links.

Figure 35 I/O Interface Board

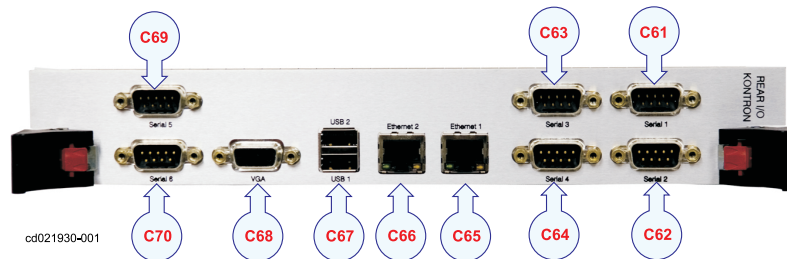

Facilities

LEDs:

None

External connections:

The following cables can be connected to the circuit board

- **C61 / C64 - Serial lines 1 - 4**, 9 pin D-sub, RS232
These cables are equipped with 9-pin connectors. These interfaces are used for connection to external sensors (position, attitude etc.).
The serial lines are normally set up as follows
 - **Serial Port 1** - Positioning systems
 - **Serial Port 2** - Motion sensor
 - **Serial Port 3** - Auxiliary 1
 - **Serial Port 4** - Auxiliary 2
- **C65 / C66 - Ethernet**, RJ45
 - **C65** – **Ethernet 1** to operator station.
 - **C66** – **Ethernet 2** is a velocity input from motion sensor. This input is needed for doppler compensation in FM mode.
- **C67 - USB**
The USB cable is equipped with a standard USB2 connector and it is only used for system testing by Kongsberg Maritime personnel.
- **C68 - VGA**
This cable is equipped with a standard 15-pin D-sub connector. This interface is only used for system testing by Kongsberg Maritime personnel.

- **C69 / C70 - Serial lines 5 and 6**, not used.

These cables are equipped with standard 9-pin D-sub connectors.

5.5.13 Raw data logger interface (RDL)

Purpose and description

This is a Gigabit Ethernet output for a raw data logger option. This “unit” is connected internally to the TRU GBit switch board.

The RDL is a real time software application that provides the capability to log raw hydrophone data from hydrographic instruments produced by Kongsberg Maritime.

The communication between the RDL and the transceiver unit uses a 1 Gbit Ethernet line.

Figure 36 RDL board



Facilities

LEDs:

- None

External connections:

- **C85 - Ethernet**
Ethernet cable to Raw data logger.

5.5.14 TX36 transmitter board

The TX36 Transmitter Board is designed for processing and transmission of transducer data.

Note

Circuit boards are delicate items. They may work year after year in an advanced product, but then fail due to a small spark of static electricity. For this reason, it is very important that they are properly handled and protected during handling.

Figure 37 TX36 Receiver Board

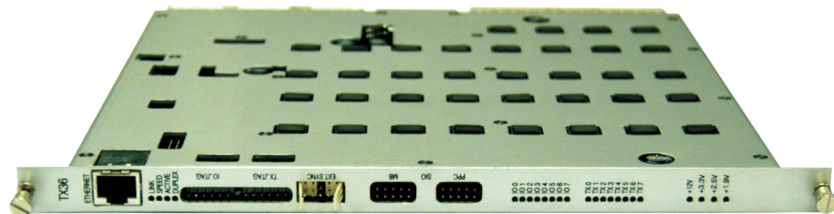

- Power supplies
- Network FPGA
- TX FPGA
- Transmitter part, 36 identical PWM transmitter channels

The TX36 Transmitter Board includes 36 independent PWM (Pulse Width Modulation) transmitters. The operating frequency is programmable within the range 10 to 500 kHz. All command input and sample data output are communicated via a 100 Mbit/s Ethernet interface.

The board includes software for synthesizing the transmit signal at runtime. A variety of different beam shapes and time signals can be generated by entering a few high level input parameters. Onboard power circuitry generates all internal voltages from a +12 Vdc input. A separate high voltage input is provided for feeding the output stage of the transmitters.

The transmitters are based on a PWM (Pulse Width Modulation) technique, with a switching frequency of 2 MHz. This makes it possible to generate arbitrary signals in the whole frequency band 10 to 500 kHz. Traditional CW pulses at any frequency or amplitude can be generated, as well as more complex waveforms, and several simultaneous signals. These signals are specified by the user and generated in the TX FPGA.

Figure 38 TX36 simplified block diagram

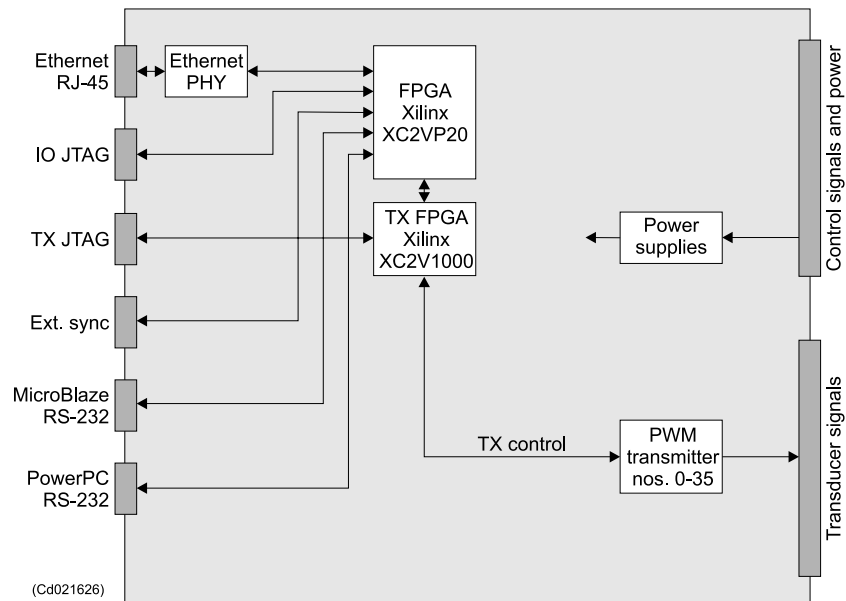

Technical specifications

These are the main technical specifications for the TX36 Receiver circuit board. Please note that technical specifications can be altered without prior warning.

Mechanical characteristics

- Type: Double “eurocard”, extended board format
- Length: 220 mm
- Height: 233.4 mm
- Width: 25.4 mm (5U)
- Weight: Approximately 950 grams

Power supply specifications

- Main supply voltages: +12 Vdc (used for the TX driver circuits) and HV (high voltage supply for the transmitter output stage)
- Maximum mean current consumption: <1 A (12V)

Transducer interface

- Number of channels: 36
- Transducer impedance: 75 ohm
- Transducer connections: Single-ended
- Transducer connector: 96-pin Euro connector

Interface specifications

- Ethernet: 10/100Mb/s

- ID0 - 4: Active high Identification Bit 0-4 (maximum 32 board address)
- CLK20MHZ: Master clock in system, 20 MHz
- RESET~: Active low, synchronized to negative edge of CLK20MHZ
- TXENABLE~: Active low, synchronized to negative edge of CLK20MHZ
- MASTER~: Active low, enables master signal source

Transmitter

- Output signal frequency range: 10 to 500 kHz
- PWM switching frequency: 20 MHz
- Output signal waveform: Arbitrary waveform, described by “Nyquist samples”
- Max. output power: 50 W
- Max. pulse length: 400 ms
- Max. duty cycle: 10 % (frequency dependant)
- High voltage supply: 0 to 170 Vdc.

Facilities

LEDs

- LINK: The connection to the external device is OK (green)
 - SPEED: The detected bit rate is 100 Mbit/s (yellow)
 - ACTIVITY: Flashing light indicates transmit and receive activity (green)
 - DUPLEX: The interface operates in full duplex mode (yellow)
- Ethernet: Four LEDs display Ethernet operating mode and activity
- TX: Eight yellow LEDs display transmission activity.

I/O

- IO 0: The PowerPC embedded program broadcasts a BOOTP/DHCP (Boot Strap Protocol / Dynamic Host Configuration Protocol) request via the Ethernet interface.
- IO 1: A BOOTP/DHCP reply message has been received from an external boot server.
- IO 2: The PowerPC sends a TFTP (Trivial File Transfer Protocol) request to the boot server asking for its application program.
- IO 3: The PowerPC embedded program is up and running. The PowerPC embedded program is included in the FPGA firmware as initialized block RAM.

- IO 4: This LED flashes when the receivers are running and generating sample data. The flash speed is proportional to the receiver decimation clock.
- IO 5: This LED is reserved for product maintenance tasks.
- IO 6: This LED flashes every time TXENABLE goes active.
- IO 7: The MicroBlaze embedded program is up and running. The MicroBlaze embedded program is included in the FPGA firmware as initialized block RAM.

I/O: Eight yellow LEDs display processor activity and error conditions.

Power

- Power: Five green LEDs indicate that the internal supply voltages are OK.
- +5 V
- +2.5 V
- +3.3 V
- +6 V
- +12 V

Figure 39 TX36

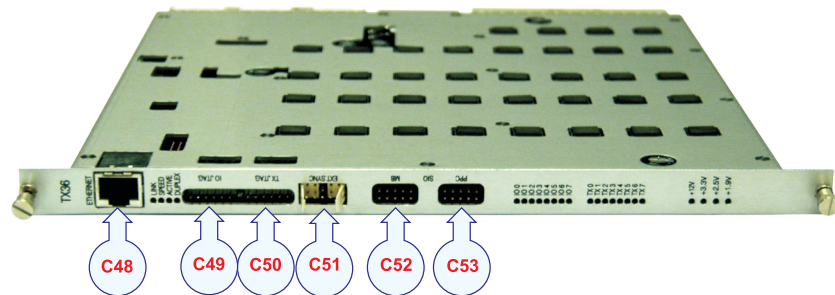

External connections

- **C48 - Connected to Ethernet switch board**

The Ethernet cable is equipped with a standard RJ-45 connector. The Ethernet interface of the TX36 transmitter board must be connected to an Ethernet switch board. This interface is used for all command input and sample data output. This is normally the only cable connected to the TX36 transmitter board. It is provided by the manufacturer.

For cable details see *Ethernet cable with RJ45* on page 144.

- **C49 - IO JTAG / For internal use only**

This cable is connected to the IO JTAG slot to provide a JTAG interface to the FGPA modules on the TX36 transmitter board. The signals of the IO JTAG slot are available at a 6-pin single line header.

Note _____

This interface is only to be used by Kongsberg Maritime personnel.

- **C50 - TX JTAG / For internal use only**

This cable is connected to the TX JTAG slot to provide a JTAG interface to the FGPA modules on the TX36 transmitter board. The signals of the TX JTAG slot are available at a 6-pin single line header.

Note _____

This interface is only to be used by Kongsberg Maritime personnel.

- **C51 - External synchronization / For internal use only**

This cable is connected to the EXT SYNC slot for accurate transmit synchronization with external equipment. The signals of the EXT SYNC slot are available at a 10-pin double line header.

Note _____

This interface is only to be used by Kongsberg Maritime personnel.

- **C52 - MicroBlaze (MB) / For internal use only**

This cable is connected to the MB slot for debugging the MicroBlaze (FPGA soft-core processor) program software. The signals of the MB slot are available at a 10-pin double line header.

Note _____

This interface is only to be used by Kongsberg Maritime personnel.

- **C53 - PowerPC (PPC) / For internal use only**

This cable is connected to the PPC slot for debugging the PowerPC (FPGA hard-core processor) program software. The signals of the PPC slot are available at a 10-pin double line header.

Note _____

This interface is only to be used by Kongsberg Maritime personnel.

5.5.15 Power Supply PSU 12V

Purpose and description

This is a 12 V / 24 A power supply. It is used to supply DC power to the TX36 Transmitter Boards. It can also deliver 72 A extra during transmit (with maximum 10 % TX duty cycle).

Figure 40 Power Supply PSU 12V

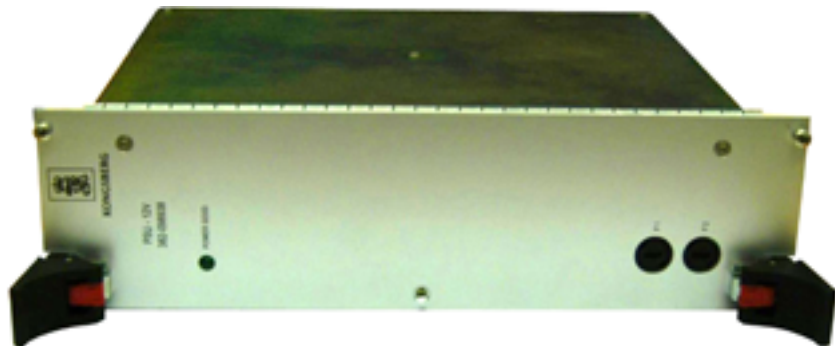

Specifications

Input:

- Maximum operating range: 90 to 264 Vac
- Nominal input voltage range: 110 to 240 Vac, 47 to 64 Hz
- Inrush current: < 10 A in 10 ms
- Power factor: > 90 %

Output:

- Output voltage: 12 Vdc \pm 2 %
- Switching frequency: 166.667 kHz
- Output current limit: < 27 A, approx. 500 ms delay
- Minimum load: 1 A
- Maximum load: 24 A continuously (dependent on number of TX36 boards)
- Maximum load: 100 A, < 400 ms
- Line regulation: $< \pm 0.2$ %
- Load regulation: $< \pm 1$ %
- Ripple and noise: < 100 mV (peak-to-peak)

Facilities

LEDs:

- Green: Power good

External connections

- None.

5.5.16 TXP RIO – Rear Interface Board

Purpose and description

This is a rear I/O module with the following features

- AC input with filter and fuse
- AC output for RX sub-rack
- Buffer for LVDS control signal
- Fuses

Figure 41 TXP RIO

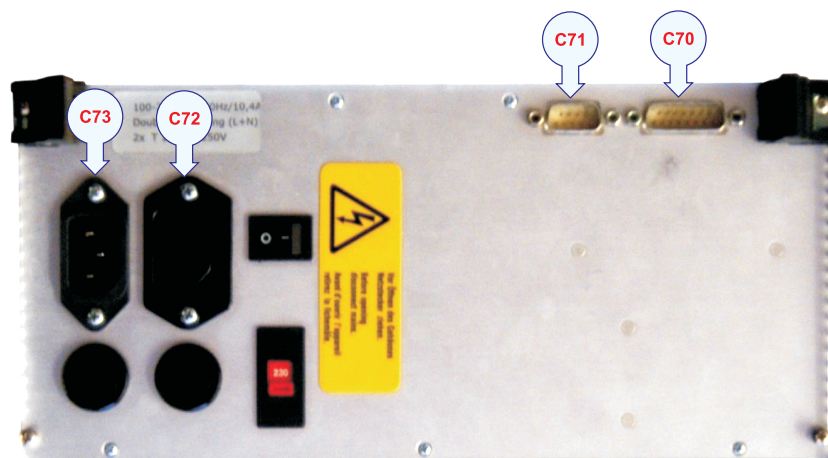

Facilities

LEDs

- None

External connections

- **C70 - Control signals connected to the BSP RIO board**

This cable is equipped with a standard 15-pin D-sub connector and is connected to the BSP RIO board. The interface is used for internal synchronization signals. This cable is provided by the manufacturer.

For cable details, see *Control signals* on page 141.

- **C71 - Remote On/Off control and synchronization**
- **C72 / 73 - AC power connected to the HVP RIO**

These are 115/230 Vac AC mains cables. The cables are equipped with a 3-pin IEC socket. C72 connects to the RxP RIO board. C71 connects the HVP RIO in the HV sub-rack. The cables are installed by the manufacturer.

For cable details, see *Standard AC power cable* on page 143

5.5.17 TX RIO – Rear Interface Board

Purpose and description

This is the rear I/O module for two TX36 Transmitter Boards. It contains a capacitor bank connected to the HV subrack Power Supply. It also connects the 72 transmitter channels to two 50-pin D-sub connectors. The transmitters have common ground.

These are Tx transducer cables terminated in 50-pin D-sub connectors. Each Tx RIO board connects to two Tx transducer cables.

Figure 42 TX RIO

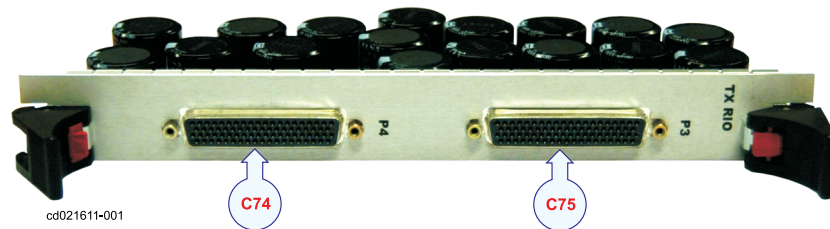

Facilities

LEDs:

- None

External connections:

The following cables can be connected to the circuit board

- **C74 / C75 - TX transducer**

via junction box

These are TX transducer cables terminated in 50-pin D-sub connectors. Each TX RIO board connects to two TX transducer cables.

For cable details, see *Tx transducer cables from junction boxes to TRU* on page 153.

5.5.18 Power Supply PSU 170V

Purpose and description

This is a 170 V / 5 A power supply. It is used to charge the capacitor modules located in the HV sub-rack and the capacitors, located on the TX RIO boards. The power supply is controlled by the CPU board via one of ethernet switch boards.

Figure 43 170 Volt power supply



Specifications

Input:

- Maximum operating range: 90 to 264 Vac
- Nominal input voltage range: 110 to 240 Vac, 47 to 64 Hz
- Inrush current: < 10 A in 10 ms
- Power factor: > 90 %

Output:

- Output voltage: 10 – 170 V
- Switching frequency: 166.667 kHz
- Output current limit: < 6 A
- Maximum load: 3.5 A continuously
- Maximum load: 6 A, < 400 ms
- Line regulation: < ± 0.2 %
- Load regulation: N/A
- Ripple and noise: < 400 mV (peak-to-peak)

Facilities

LEDs:

- Green: Power good

External connections

- **C86 - Ethernet connection**

Ethernet cable connected to an Ethernet switch Board, using standard RJ 45 connectors. See *Ethernet cable with RJ45* on page 144

5.5.19 Capacitor board

Purpose and description

This module contains 35 capacitors used to store the energy needed for the transmit pulse.

Figure 44 Capacitor board

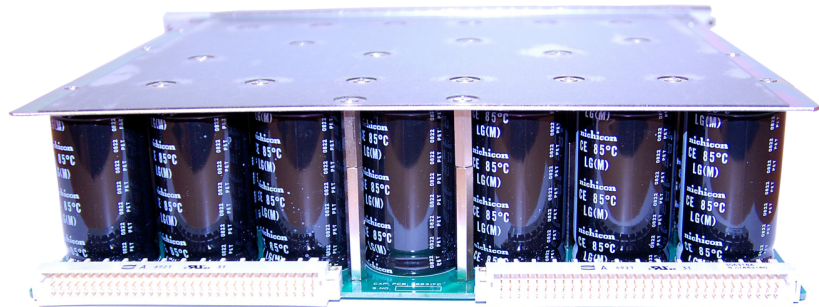

Specifications

- Temperature Range: – 40 to +85°C
- Rated voltage: 180 V
- Rated capacitance: 2700 µF * 35
- Tolerance rated capacitance: – 20 to +20%
- Diameter - D: 30mm
- Length - L: 50mm
- Rated ripple current (at 120 Hz): 4700 mA

5.5.20 HVP RIO

Purpose and description

This is a rear I/O module with the following features

Figure 45 HVP RIO

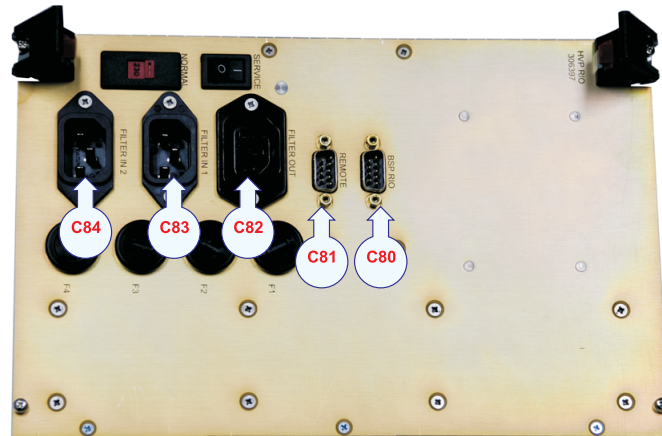

- AC inputs with filters and fuses
- Relay for remote control
- AC output for TX sub-rack
- A heater resistor (20 to 30 W)
- An active bleeder for the 170 V Power Supply
- 24 V stand-by power supply

Fuses

5x20mm, T 16A, 250VAC

If remote on/off is connected the physical power switch must be in the O position.

Facilities

The following cables can be connected to the circuit board.

External connections

- **C80 – BSP RIO (sync. signals)**

This is a link signal to BSP RIO Trig in/out (C58) with a 9–pins connector.

The cable is installed by the manufacturer.

- **C81 – Synchronisation and Remote Control**

This cable is equipped with a standard 9-pin D-sub connector. The interface is used to connect to a remote On/Off power switch. It is also used for external trigger output and synchronization.

An external system may be used to synchronise the echo sounder's transmissions. This system is connected to the Remote plug on the Transceiver Unit.

In most cases, an external Remote Control junction box is located in the vicinity of the Operator Station to facilitate on/off control. The cable from this box is connected to the **Remote** plug on the Transceiver Unit.

External synchronisation and remote on/off on page 43

The cable must be provided by the installation shipyard.

- **C82 - Filtered AC power output connected to TXP-RIO**

Power supply male equivalent socket connected to RIO TxP. The cable is installed by the manufacturer.

- **C83 / C84 - Mains AC power input**

These are 115/230 Vac AC mains cables to the Transceiver Unit. Cable C83 and C84 must be equipped with a 3-pin IEC female socket.

C83 and C84 must be connected to the ship's local power supply.

The cables must be supplied by the installations shipyard.

Important _____

The TRU is normally used for 230V AC. For 115V AC, switches on HVP RIO, TxP RIO and RxP RIO must be set to correct position.

Otherwise the equipment may be damaged.

6 PREAMPLIFIER UNIT

Description and main functions

The EM 122 Preamplifier Unit preamplifies the signals from the hydrophones.

The EM 122 Preamplifier Unit contains the preamplifiers for the receive signals. The unit also provides the frequency splitting circuitry to feed low frequency signals to the optional Sub Bottom Profiler.

This chapter provides the following information:

Topics

- *Theory of operation* on page 95
- *Preamplifier Unit details* on page 96
- *Circuit board descriptions* on page 96

Figure 46 EM 122 Preamplifier Unit - Outline dimensions

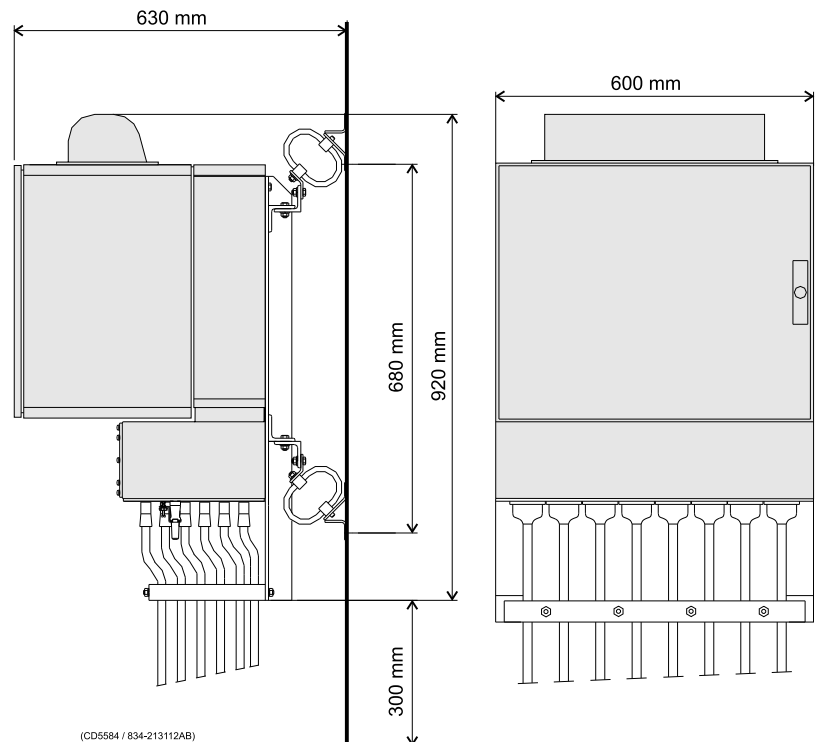
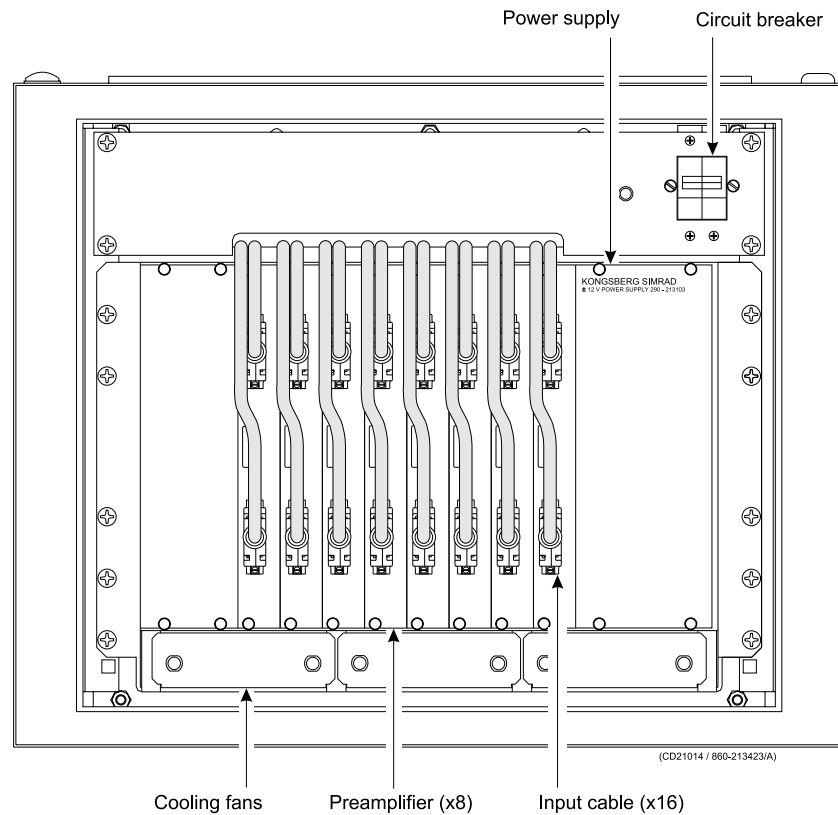

Figure 47 EM 122 Preamplifier Unit - wired cabinet



6.1 Theory of operation

This chapter presents a functional description of the Preamplifier Unit.

Simplified block diagram

The simplified block diagram for the preamplifier Unit present the following main functions:

Figure 48 Block diagram of one of the channels.

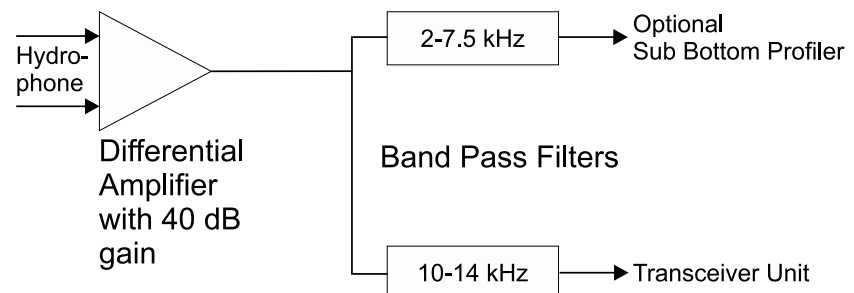

(cd021102-001)

Control functions

The preamplifier has no external control interface, and the power is on all the time. (No remote control).

Cooling

The fans usually operate with 230 Vac, and must therefore be changed if 110 Vac is used.

For external cabling, please refer to the chapter concerning transducer cables *Transducer cables* on page 27.

6.2 Preamplifier Unit details

Circuit boards and modules

Preamplifier

Two, four or eight DP16 preamplifier boards are mounted in this unit.

A 1° Rx system needs eight boards, a 2° Rx system needs four boards and a 4° Rx system needs two boards.

The circuit board is explained on *Circuit board descriptions* on page 96

Power Supply

This is a linear commercial power supply, that feeds power to the preamplifier unit.

The power supply is explained on *Preamplifier Unit Power Supply (PAPS)* on page 101

Backplane

The Preamplifier Unit uses a passive backplane

The backplane is explained on *Preamplifier Backplane* on page 102

6.3 Circuit board descriptions

This chapter describes all the circuit boards and modules in the EM 122 Preamplifier Unit. A functional description with a block diagram is provided, as well as the facilities provided for maintenance.

Simplified block diagram

The block diagram shows one of the 8 channels:

Figure 49 Block diagram of one of the 16 channels.

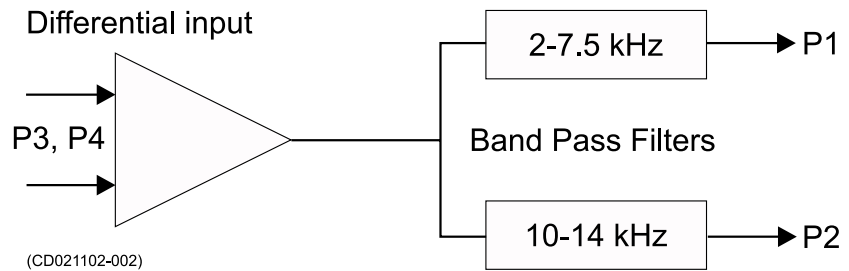

6.3.1 Preamplifier (DP16)

Purpose and description

The purpose of the Preamplifier is to amplify and filter the signals from the hydrophones.

How it works

2, 4 or 8 preamplifier circuit boards (DP16) are mounted in this unit. The DP16 is a 16-channel, dual preamplifier for the EM 122 multibeam echo sounder. Each channel consists of a differential input preamplifier, followed by two parallel filters, one bandpass filter for a 2 - 7.5 kHz passband, one for a 10 - 14 kHz passband. The nominal gain for both channels is 40.0 dB.

Figure 50 Block diagram of one of the channels.

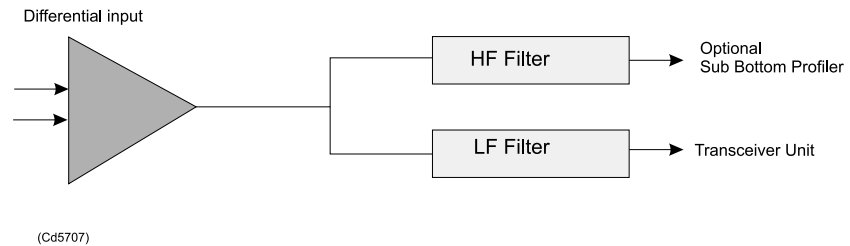

This HF filter is a passive LCR filter with adjustable inductors. The LF filter is a standard active filter with no adjustable components.

Facilities

LEDs

None

Test points

The table below shows the available test points on the circuit board:

| Testpoints | Description |
|------------|--------------------------------|
| LK1 | Probe ground point (scopelink) |

| Testpoints | Description |
|------------|--------------------------------|
| TP17 | + 8 V regulated supply voltage |
| TP18 | - 8 V regulated supply voltage |
| TP1 | Channel 16 preamplifier output |
| TP2 | Channel 15 preamplifier output |
| TP3 | Channel 14 preamplifier output |
| TP4 | Channel 13 preamplifier output |
| TP5 | Channel 12 preamplifier output |
| TP6 | Channel 11 preamplifier output |
| TP7 | Channel 10 preamplifier output |
| TP8 | Channel 9 preamplifier output |
| TP9 | Channel 8 preamplifier output |
| TP10 | Channel 7 preamplifier output |
| TP11 | Channel 6 preamplifier output |
| TP12 | Channel 5 preamplifier output |
| TP13 | Channel 4 preamplifier output |
| TP14 | Channel 3 preamplifier output |
| TP15 | Channel 2 preamplifier output |
| TP16 | Channel 1 preamplifier output |

Connections

Input signals from the hydrophones are connected on the front of the pcb (P3, P4). Output signals to Transceiver Unit and to optional Sub Bottom Profiler is connected to the backplane (P2 for TRU, P1 for Sub Bottom Profiler).

Connector P1 and P2 are 96 pin euro edge connectors.

Connector P3 and P4 are 25 pin D-sub connectors.

The table below shows the connections for P1.

| A | Signal | B | Signal | C | Signal |
|--------|--------|--------|--------|--------|--------|
| a - 1 | VCC | b - 1 | VCC | c - 1 | VCC |
| a - 2 | VCC | b - 2 | VCC | c - 2 | VCC |
| a - 3 | VCC | b - 3 | VCC | c - 3 | VCC |
| a - 4 | VCC | b - 4 | VCC | c - 4 | VCC |
| a - 5 | VCC | b - 5 | VCC | c - 5 | VCC |
| a - 6 | GND | b - 6 | GND | c - 6 | GND |
| a - 7 | GND | b - 7 | GND | c - 7 | GND |
| a - 8 | GND | b - 8 | GND | c - 8 | GND |
| a - 9 | GND | b - 9 | GND | c - 9 | LF_16 |
| a - 10 | GND | b - 10 | GND | c - 10 | LF_15 |
| a - 11 | GND | b - 11 | GND | c - 11 | LF_14 |
| a - 12 | GND | b - 12 | GND | c - 12 | LF_13 |
| a - 13 | GND | b - 13 | GND | c - 13 | LF_12 |

| A | Signal | B | Signal | C | Signal |
|----------|---------------|----------|---------------|----------|---------------|
| a - 14 | GND | b - 14 | GND | c - 14 | LF_11 |
| a - 15 | GND | b - 15 | GND | c - 15 | LF_10 |
| a - 16 | GND | b - 16 | GND | c - 16 | LF_9 |
| a - 17 | GND | b - 17 | GND | c - 17 | LF_8 |
| a - 18 | GND | b - 18 | GND | c - 18 | LF_7 |
| a - 19 | GND | b - 19 | GND | c - 19 | LF_6 |
| a - 20 | GND | b - 20 | GND | c - 20 | LF_5 |
| a - 21 | GND | b - 21 | GND | c - 21 | LF_4 |
| a - 22 | GND | b - 22 | GND | c - 22 | LF_3 |
| a - 23 | GND | b - 23 | GND | c - 23 | LF_2 |
| a - 24 | GND | b - 24 | GND | c - 24 | LF_1 |
| a - 25 | GND | b - 25 | GND | c - 25 | GND |
| a - 26 | GND | b - 26 | GND | c - 26 | GND |
| a - 27 | GND | b - 27 | GND | c - 27 | GND |
| a - 28 | VEE | b - 28 | VEE | c - 28 | VEE |
| a - 29 | VEE | b - 29 | VEE | c - 29 | VEE |
| a - 30 | VEE | b - 30 | VEE | c - 30 | VEE |
| a - 31 | VEE | b - 31 | VEE | c - 31 | VEE |
| a - 32 | VEE | b - 32 | VEE | c - 32 | VEE |

The table below shows the connections for P2.

| A | Signal | B | Signal | C | Signal |
|----------|---------------|----------|---------------|----------|---------------|
| a - 1 | VCC | b - 1 | VCC | c - 1 | VCC |
| a - 2 | VCC | b - 2 | VCC | c - 2 | VCC |
| a - 3 | VCC | b - 3 | VCC | c - 3 | VCC |
| a - 4 | VCC | b - 4 | VCC | c - 4 | VCC |
| a - 5 | VCC | b - 5 | VCC | c - 5 | VCC |
| a - 6 | GND | b - 6 | GND | c - 6 | GND |
| a - 7 | GND | b - 7 | GND | c - 7 | GND |
| a - 8 | GND | b - 8 | GND | c - 8 | GND |
| a - 9 | GND | b - 9 | GND | c - 9 | HF_16 |
| a - 10 | GND | b - 10 | GND | c - 10 | HF_15 |
| a - 11 | GND | b - 11 | GND | c - 11 | HF_14 |
| a - 12 | GND | b - 12 | GND | c - 12 | HF_13 |
| a - 13 | GND | b - 13 | GND | c - 13 | HF_12 |
| a - 14 | GND | b - 14 | GND | c - 14 | HF_11 |
| a - 15 | GND | b - 15 | GND | c - 15 | HF_10 |
| a - 16 | GND | b - 16 | GND | c - 16 | HF_9 |
| a - 17 | GND | b - 17 | GND | c - 17 | HF_8 |
| a - 18 | GND | b - 18 | GND | c - 18 | HF_7 |
| a - 19 | GND | b - 19 | GND | c - 19 | HF_6 |
| a - 20 | GND | b - 20 | GND | c - 20 | HF_5 |

| A | Signal | B | Signal | C | Signal |
|----------|---------------|----------|---------------|----------|---------------|
| a - 21 | GND | b - 21 | GND | c - 21 | HF_4 |
| a - 22 | GND | b - 22 | GND | c - 22 | HF_3 |
| a - 23 | GND | b - 23 | GND | c - 23 | HF_2 |
| a - 24 | GND | b - 24 | GND | c - 24 | HF_1 |
| a - 25 | GND | b - 25 | GND | c - 25 | GND |
| a - 26 | GND | b - 26 | GND | c - 26 | GND |
| a - 27 | GND | b - 27 | GND | c - 27 | GND |
| a - 28 | VEE | b - 28 | VEE | c - 28 | VEE |
| a - 29 | VEE | b - 29 | VEE | c - 29 | VEE |
| a - 30 | VEE | b - 30 | VEE | c - 30 | VEE |
| a - 31 | VEE | b - 31 | VEE | c - 31 | VEE |
| a - 32 | VEE | b - 32 | VEE | c - 32 | VEE |

The table below shows the connections for P3.

| Pin | Signal | Description |
|------------|---------------|---------------------------|
| 1 | | |
| 2 | | |
| 3 | IN_HI_1 | Channel 1 input high side |
| 4 | IN_HI_2 | Channel 2 input high side |
| 5 | IN_HI_3 | Channel 3 input high side |
| 6 | IN_HI_4 | Channel 4 input high side |
| 7 | IN_HI_5 | Channel 5 input high side |
| 8 | IN_HI_6 | Channel 6 input high side |
| 9 | IN_HI_7 | Channel 7 input high side |
| 10 | IN_HI_8 | Channel 8 input high side |
| 11 | | |
| 12 | | |
| 13 | | |
| 14 | | |
| 15 | | |
| 16 | IN_LO_1 | Channel 1 input low side |
| 17 | IN_LO_2 | Channel 2 input low side |
| 18 | IN_LO_3 | Channel 3 input low side |
| 19 | IN_LO_4 | Channel 4 input low side |
| 20 | IN_LO_5 | Channel 5 input low side |
| 21 | IN_LO_6 | Channel 6 input low side |
| 22 | IN_LO_7 | Channel 7 input low side |
| 23 | IN_LO_8 | Channel 8 input low side |
| 24 | | |
| 25 | | |

The table below shows the connections for P4.

| Pin | Signal | Description |
|-----|----------|----------------------------|
| 1 | | |
| 2 | | |
| 3 | IN_HI_9 | Channel 9 input high side |
| 4 | IN_HI_10 | Channel 10 input high side |
| 5 | IN_HI_11 | Channel 11 input high side |
| 6 | IN_HI_12 | Channel 12 input high side |
| 7 | IN_HI_13 | Channel 13 input high side |
| 8 | IN_HI_14 | Channel 14 input high side |
| 9 | IN_HI_15 | Channel 15 input high side |
| 10 | IN_HI_16 | Channel 16 input high side |
| 11 | | |
| 12 | | |
| 13 | | |
| 14 | | |
| 15 | | |
| 16 | IN_LO_9 | Channel 9 input low side |
| 17 | IN_LO_10 | Channel 10 input low side |
| 18 | IN_LO_11 | Channel 11 input low side |
| 19 | IN_LO_12 | Channel 12 input low side |
| 20 | IN_LO_13 | Channel 13 input low side |
| 21 | IN_LO_14 | Channel 14 input low side |
| 22 | IN_LO_15 | Channel 15 input low side |
| 23 | IN_LO_16 | Channel 16 input low side |
| 24 | | |
| 25 | | |

6.3.2 Preamplifier Unit Power Supply (PAPS)

Purpose and description

The power supply feeds power to the preamplifier unit.

How it works

Commercial Linear supply mounted in a plug in unit.

Figure 51 Preamplifier Power Supply

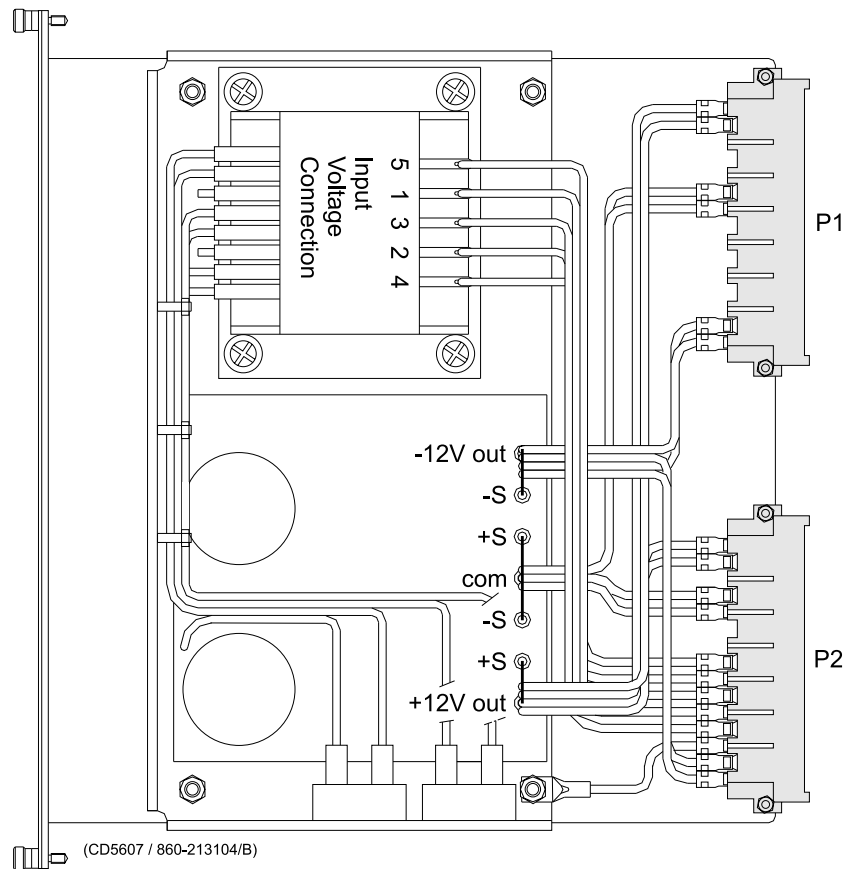

Facilities

LEDs

None

Test points

None

Links

None (AC main selection is done on the backplane).

6.3.3 Preamplifier Backplane

Purpose and description

The purpose of the Preamplifier Backplane is to enable communication between the circuit boards plugged into it, and between these circuit boards and the external circuitry in the cabinet. The Preamplifier Backplane holds the following circuit boards / modules:

- Preamplifier (x8)
- Power Supply.

Figure 52 The Preamplifier Backplane

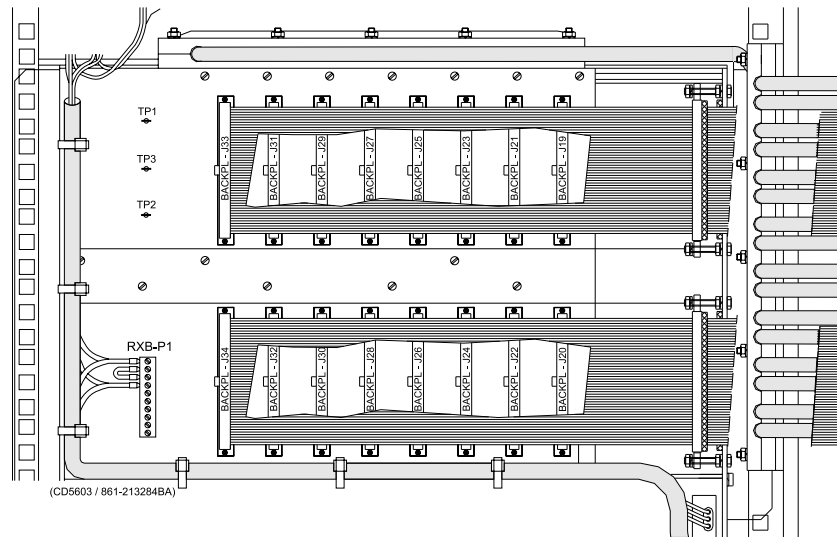

How it works

There are no active components on this backplane.

Facilities

LEDs

None

Test points

- TP1: +12V
- TP2: -12V
- TP3: GND
- TP4: GND
- TP5: GND

Links

Figure 53 Pin configuration

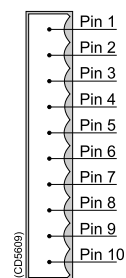

| AC Input for use at: | 100 V AC | 120 V AC | 220 V AC | 230/240 V AC |
|-----------------------------|-----------------|-----------------|-----------------|---------------------|
| Jumper | 2/4 | 1/3 2/4 | 1/3 2/3 | 2/3 |
| Apply AC | 1/5 | 4/1 | 1/5 | 4/1 |

Connections

If 230 Vac:

| RXB-P1 | Signal | Connection |
|---------------|---------------|-------------------------------|
| 1 | AC mains | Fuse |
| 1 | AC mains | Fan |
| 4 | AC mains | Fuse |
| 4 | AC mains | Fan |
| Backpl-J19 | | BP-SBP1 (Sub Bottom Profiler) |
| Backpl-J20 | | BP-R1 (TRU) |
| Backpl-J21 | | BP-SBP2 |
| Backpl-J22 | | BP-R2 |
| Backpl-J23 | | BP-SBP3 |
| Backpl-J24 | | BP-R3 |
| Backpl-J25 | | BP-SBP4 |
| Backpl-J26 | | BP-R4 |
| Backpl-J27 | | BP-SBP5 |
| Backpl-J28 | | BP-R5 |
| Backpl-J29 | | BP-SBP6 |
| Backpl-J30 | | BP-R6 |
| Backpl-J31 | | BP-SBP7 |
| Backpl-J32 | | BP-R7 |
| Backpl-J33 | | BP-SBP8 |
| Backpl-J34 | | BP-R8 |

Figure 54 Preamplifier Backplane, front side.

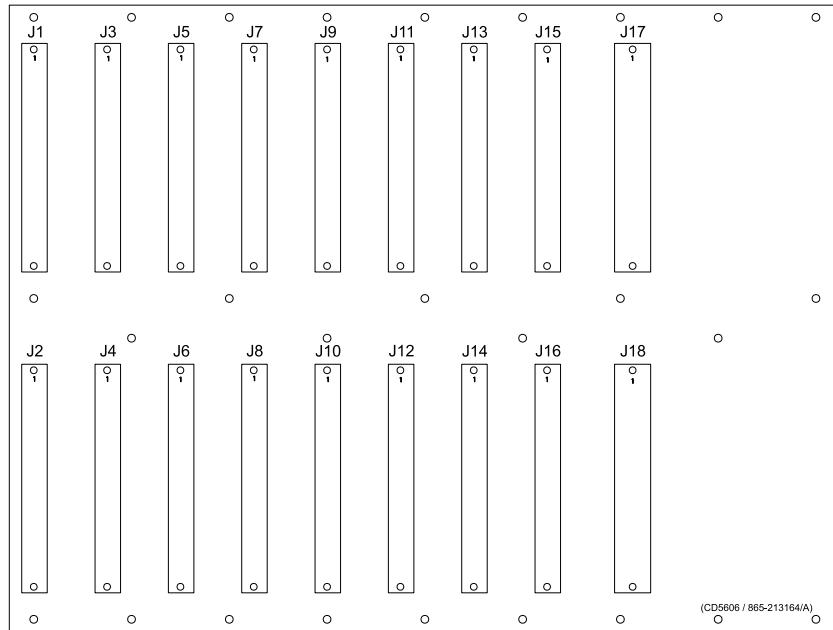
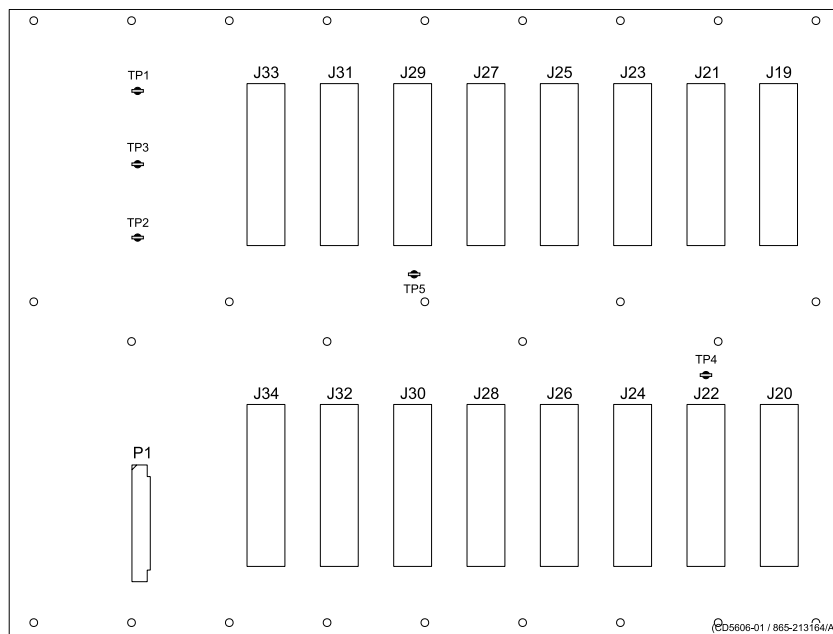

Figure 55 Preamplifier Backplane, rear side.



7 TX JUNCTION BOXES

Description

This box is only made for routing of transmit signals. There are no components inside the box, but a PCB with several “D” connectors mounted. Each of the 48 TX modules has a cable with a 25-pin “D” connector in the end. The transmit section output from the TRU have 24 pcs of 50-pin “D” connectors.

The function of the TX-junction box is to route signals from 2 pcs of 25-pin “D” connectors to one 50-pin “D” connector.

There are 6 boards in one TX junction box. Each board is then routing 4 pcs of 25-pin “D” connectors to 2 pcs of 50-pin “D” connectors.

Figure 56 TX Routing PCB

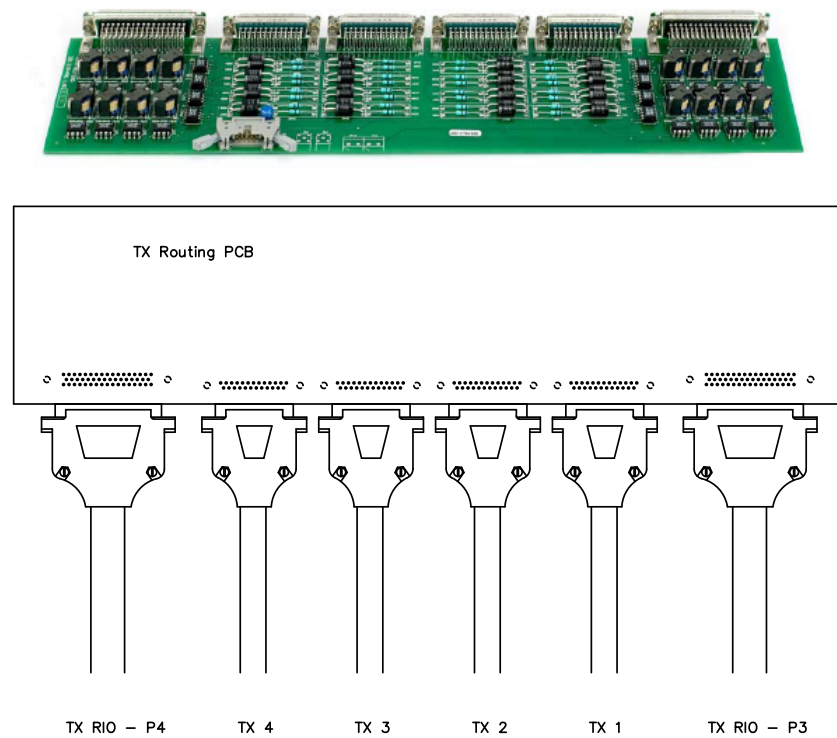

8 TROUBLESHOOTING

Introduction

The EM 122 provides numerous messages to inform you of major and minor hardware and software errors.

The messages, if they occur, will be displayed in SIS' Message service window and/or in the Status bar.

The different utilities operating on the EM 122 Operator Station each issue several messages. These messages can be sorted in three categories:

- Information
- Warnings
- Errors

The messages presented as warnings merely point out small inaccuracies, and must be regarded as guidelines to the normal operation of the system.

The operational errors reflect major and minor hardware and software errors, some of which must be acted upon to ensure the normal operational capability.

Refer to the Seafloor Information System (SIS) Operator manual for further information.

8.1 BIST tests

BSP - Beamformer and Signal Processing

This test checks all Beamformer and Signal Processing circuit boards in the EM 122 Transceiver Unit.

TX36 - Transmitter board

This test checks all TX36 transmitter circuit boards in the EM 122 Transceiver Unit (voltage, current and temperature).

RX32 - Receiver board

This test checks all RX32 receiver circuit boards in the EM 122 Transceiver Unit (voltage, current and temperature).

TRU Power - Transceiver unit

This test checks the 6 V, 12 V and the High Voltage power supplies in the EM 122 Transceiver Unit. The power levels are tested on all RX and TX boards. The High voltage power is charged to maximum power level before tested. This may take some time.

TX Power

This test checks the High Voltage power supply function. The power level is controlled by the CPU card. In addition the power supply controls an external bleeder (located in the HV sub rack) that is used to reduce the power level. Several power levels are tested. The charging and the bleeding of the large capacitor battery are slow, so this test may take several minutes.

RX 32 / BSP link

This test checks the nibble bus interface between the RX 32 receiver circuit boards and the BSP circuit boards. A large set of known data is transferred from each of the RX 32 receiver boards to the BSP board. The data received by the BSP is verified.

RX channels

This test checks all RX channels on the RX 32 receiver boards. A built in signal generator is used to verify the gain and the phase response. The BIST report lists phase and amplitude response of all RX channels.

TX channels

This test checks all TX channels (including the transducers). This is done by transmitting at one by one TX amplifier. The output voltage and current is measured. This data is used to calculate the transducer element impedance. BIST report lists channels outside the limits.

RX noise level (broadband)

This test measures the average isotropic spectral noise level for each receiver channel (in dB rel 1 μ Pa/Hz). A large number of samples are acquired, the frequency spectrum is calculated, and the spectral components within 10 to 13 kHz are used to calculate the average noise level. The receiver directivity index, the transducer sensitivity and the bandwidth is used to convert to isotropic spectral noise level.

RX noise spectrum

This test measures the receiver noise spectrum (FFT). It shows the noise spectrum for each RX 32 board (in dB rel 1 μ Pa/Hz). It is the average noise for the 32 channels. The noise is displayed with steps of 140 Hz from 10 to 14 kHz.

TRU software date / version

This test presents the software date and version for various units in the system.

CPU

This test presents the CPU type, the CPU clock frequency, the current and maximum temperatures for the CPU die and for the CPU board. In addition some key voltages are reported, and finally the network addresses for the board's interfaces.

9 REPLACEMENT PROCEDURES

Overview

This chapter presents the basic procedures for disassembly and reassembly of the replaceable parts in the EM 122 system.

A standard tool set is required to perform the removal and replacement of the modules. This tool set should contain the following tools:

Safety precautions

The system operates on 115 and/or 230 Vac, 50/60 Hz.

WARNING

This voltage can be lethal.

System power must be switched off before any replacement is carried out. Failure to do so may lead to personal injury, and/or serious damage to the system.

ESD precautions

The replacement procedures presented in this chapter allows you to replace circuit boards. These are delicate devices, and special attention must be made to the handling of these.

The following precautions are therefore very important:

- The working area must be covered by an approved conductive service mat that has a resistance of between 50 k Ω and 2 M Ω , and is connected directly to a reliable ground point via its grounding cord.
- The maintenance technician or engineer must use a grounding bracelet, firmly connected to an ESD grounding point.
 - The bracket in the upper left corner of the TRU serves as ESD grounding point when working in front of the cabinet.
 - The two profile beams mounted on each side wall of the cabinet serves as ESD grounding points when working at the back of the cabinet.
- All circuit boards must be stored in anti-static bags while not in use.

A standard tool set is required to perform the removal and replacement of the modules. This tool set should contain the following tools:

Tools required

- Cabinet key
- Standard screwdrivers in different widths and lengths

- Standard cross-slot screwdrivers in different widths and lengths
- Allen keys in metric sizes
- Philips screwdrivers in different sizes
- Pozidrive screwdrivers in different sizes
- Flat nosed pliers
- Lap jointed pliers
- Wire cutters
- Adjustable spanners
- Socket set
- Wire straps in different sizes

9.1 Procedures for Transceiver Unit

The replaceable units in the EM 122 Transceiver Unit are:

Processing and receiver rack

- cPCI Power Supply
- CPU Board
- BSP 67B Boards
- Ethernet Switch Boards
- Power Supply PSU 6V
- RX32 Receiver Boards
- RX RIO Rear Interface Boards
- RXP RIO Rear interface Module
- BSP RIO Rear Interface Board
- Rear I/O Interface Board
- Fuses
- Fan drawers (2 pcs)

Transmitter rack

- Power Supply PSU 12V
- TX36 Transmitter Boards
- TX RIO Rear Interface Boards
- TXP RIO Rear Interface Board
- Fuses
- Fan drawer

High Voltage rack

- Power Supply PSU 170V
- Cap PCB

- HVP RIO 306397
- Fuses
- Fan drawer

The replacement procedures for these parts are described in the following disassembly and reassembly procedures.

Circuit boards and power supplies

The Transceiver Unit holds three sub-racks. All the sub-racks hold plug-in circuit boards.

The replacement of these modules is described in this procedure.

The system must be switched off prior to disassembly. Access is gained to the sub-racks by opening the front door of the Transceiver Unit with a special tool for the cabinet doors. Before removing any modules, be sure that the led in the HV Power supply has no green light on.

Disassembly procedure

- Remove the front mounted cables from the applicable circuit boards
- Release the thumb-screws and other screws if required
- Pull the board/unit carefully out

Replacement procedure

- 1 Insert new circuit boards and modules in reverse order. Mount the front mounted ethernet cable connectors.
- 2 Check that the circuit boards and modules have been installed in their correct locations! Refer to the applicable pictures and drawings.

9.2 Power Supply

There are two power supplies located in the Processing and Receiver Rack. CPCI Power on the left side and one 6 Volt power supply between the Ethernet cards and RX 32 receiver cards.

In the Transmitter sub-rack there are one 12 Volt power supply on the left side.

The HV sub-rack contains one 170 Volt power supply on the left side.

Disassembly procedure

- 1 Open the front door of the Transceiver Unit.
- 2 Switch off the circuit breaker on the rear side at the HV sub-rack.

Caution

Do not pull out the unit before the voltmeter shows zero (0) voltage.

- 3 Unbolt the unit. It is mounted with four screws so they cannot fall out.
- 4 Release the screws
- 5 Pull out the unit carefully

Reassembly procedure

- 1 The new power supply is replaced by reversing the above procedure

9.3 Fuse replacement

The Transceiver Unit holds several power supplies. Three of these are equipped with primary fuses marked with F1 and F2.

These fuses are mounted in the front on:

- 6 V Power supply
- 12 V Power supply
- 170 V Power supply

Disassembly procedure

- Release the fuse with a screwdriver

Reassembly procedure

- Replace with the same type of fuse by reversing above procedure

9.4 Fan drawers

There are four fan drawers in the Transceiver Unit. Two fan drawers are located underneath the Processing and Receiver sub-rack, one underneath the Transmitter sub-rack and one Underneath the HV sub-rack.

Access is gained to the sub-racks by opening the front protective cover of the Transceiver Unit.

WARNING

The system must be switched off prior to disassembly.

How to disassembly fan drawers

- 1 Gain access to the wired rack.
- 2 Twist the right and left screw on the fan drawer a few turns.

- 3 Pull the fan drawer carefully out.

How to reassembly fan drawers

- 1 Reverse the above procedure.

10 MAINTENANCE PROGRAM

The purpose of this document is to provide guidance to operators and maintainers on recommended maintenance procedures for multi beam echo sounders and ancillary equipment. The guidelines will assist in keeping the equipment fully operational and in detecting problems and malfunctions as early as possible.

10.1 Before every survey (alongside)

The following systems shall be maintained:

Remove old surveys.

If possible, delete all surveys from the hard disks on the EM Operator stations. This will ensure that different surveys are not mixed together and that all data disks are empty at survey start.

Defragment all survey disks.

At survey start, and during the survey (if time allows), defragment the data disk(s). This is performed to optimise the disk capacity.

Run all BISTS.

The system has several BIST incorporated in the system software. Run all these to verify correct system operation or take corrective action if any alarms appears.

Verify operation of all external sensors.

The various multi beam echo sounders are part of an integrated system with several external sensors. Verify operation of each ancillary system using the relevant technical and operational manuals. Perform corrective actions if necessary.

10.2 Before every survey (offshore)

Roll calibration check

Perform a Roll calibration as described in the operator manual and verify if any roll offset values have changed. If different from the last check, update and verify.

Pitch calibration check

Perform a Pitch calibration as described in the operator manual and verify if any pitch offset values have changed. If different from the last check, update and verify.

Cross line verification check

To check the sound speed corrections, run two lines perpendicular to each other and verify the swath versus the centre beam.

10.3 Every time used

Clean the SVP probe in fresh water.

Each time the SVP unit is used, it shall be cleaned in fresh water and stored in a dry and safe place. Verify that no physical damage is done to the unit and that the sacrificial anodes (if any) are all intact.

10.4 Every 6 months

Check all external cables

All interface cables are connected to the various electronic units by delta connectors or similar. Verify that all connectors are securely fastened and that all cables are free from physical damage.

Clean all air filters

Wherever there are air filters, they shall be cleaned at least every 6 months. If the units are installed in a dirty environment, then shorter intervals between cleaning may be required.

Hoover the inside of every cabinet.

Each cabinet should be cleared of dust and other particles at least every 6 months. A suitable Hoover should be used for this work, ensuring that no metallic parts are used inside the cabinets. System power must be isolated prior to cleaning.

WARNING

UTMOST CARE MUST BE TAKEN DURING THIS OPERATION

10.5 Every dry-docking

Docking

WARNING

For cleaning – do not use high pressure cleaner or simular.

All transducers should be checked when the ship is in dry-dock. Remove very carefully all marine growth with only a **wood** or **plastic** ice scraper. Then renew the anti fouling paint on the transducer faces. Great care must be taken when performing this.

How to do replace the anti fouling paint

- The transducer has to be rubbed softly with hand with a very fine sand paper.

- A thin layer of primer dependent of the frequency of the system
- Antifouling type SeaQuantum Ultra, Layer thickness 125 micron

Primer on 300kHz and 200kHz systems: Penguin primer, 75 micron layer thickness.

Primer on all other systems: Safeguard Universal ES, 125 micron layer thickness.

Note

The last primer is giving the best protection but contains micro sized aluminium grains and has yet not been tested for 200 and 300 kHz systems.

This is Kongsberg Maritime's list of approved antifouling paints on polyurethane transducer housing.

From Jotun Paints, Sandefjord Norway

- Antifouling Seamate HB 33
- Antifouling Seamate HB 66
- Antifouling Seamate HB 99
- Racing
- Non-stop

From International Paints

- Intersleek tie coat +425 FCS
 - BXA386/BXA390/BXA391 grey
 - HKA563/HKA570/HKA571 Yellow

Mix BXA386, BXA390 and BXA391 first, then apply. When dry, mix HKA563, HKA570 and HKA571, apply.

From Hempel IFA Coatings AS

- Hempel A/F Classic 76550

From Jotun-Henry Clark Ltd

- Anti-fouling Seaguardian

Note

refer to the manufacturer's documentation and data sheets for a complete procedure.

Diver

There is also one opportunity for a diver to the gently scrap of the arrays with a **wood** or **plastic** scraper.

11 SPARE PARTS

This chapter contains an illustrated presentation of the spare parts available for the EM 122 multibeam echo sounder. All parts are minimum of what we recommend onboard and at site.

Spares onboard

Table 12 Power Supplies

| Pc | Our part nr. | Parts |
|----|--------------|-----------------------|
| | 398255 | Selection of fuses |
| 1 | 382-099656 | Power Supply cPCI |
| 1 | 382-098939 | Power Supply PSU-6 V |
| 1 | 302991 | Power Supply PCU-12 V |
| 1 | 302992 | Power Supply PSU-HV |
| 1 | 290-085008 | BIOS Battery for CPU |

Table 13 Receiver Unit

| Pc | Our part nr. | Parts |
|----|--------------|-------------------------|
| | 308879 | CPU Board Kontron KIT |
| 1 | 310231 | PCB BSP67B |
| 1 | 309057 | PCB RX 32 |
| 1 | 308301 | Interface card RX RIO |
| 1 | 302124 | CPU Inteface card RIO |
| 1 | 328545 | Gigabit Ethernet Switch |

Table 14 Transmitter Unit

| Pc | Our part nr. | Parts |
|----|--------------|-----------------------|
| 1 | 307677 | PCB TX 36 |
| 1 | 303424 | Interface Card TX RIO |

Table 15 High Voltage Unit

| Pc | Our part nr. | Parts |
|----|--------------|---------------------------|
| 1 | 306318 | Capacitor module, CAP PCB |

Table 16 On request – Not included in the spare part kit

| Pc | Our part nr. | Parts |
|----|--------------|--|
| 1 | 306397 | Interface card HV with bleeder, heater and remote on/off |

Spares at site

Table 17 Power Supplies

| Pc | Our part nr. | Parts |
|----|--------------|-----------------------|
| | 398255 | Selection of fuses |
| 1 | 382-099656 | Power Supply cPCI |
| 1 | 382-098939 | Power Supply PSU-6 V |
| 1 | 302991 | Power Supply PCU-12 V |
| 1 | 302992 | Power Supply PSU-HV |
| 1 | 290-085008 | BIOS Battery for CPU |

Table 18 Receiver Unit

| Pc | Our part nr. | Parts |
|----|--------------|-------------------------|
| | 311806 | CPU Board Kontron KIT |
| 1 | 302124 | CPU Interface card RIO |
| 1 | 310231 | PCB BSP67B |
| 1 | 316694 | Interface card RIO BSP |
| 1 | 309057 | PCB RX 32 |
| 1 | 308301 | Interface card RX RIO |
| 1 | 719-098950 | Mega Ethernet Switch |
| 1 | 328545 | Gigabit Ethernet Switch |
| 1 | 309083 | FAN Unit CPU Section |
| 1 | 309082 | FAN Unit RX 32 section |

Table 19 Transmitter Unit

| Pc | Our part nr. | Parts |
|----|--------------|-----------------------|
| 1 | 307677 | PCB TX 36 |
| 1 | 303424 | Interface Card TX RIO |

Table 20 High Voltage Unit

| Pc | Our part nr. | Parts |
|----|--------------|--|
| 1 | 306397 | Interface card HV with bleeder, heater and remote on/off |
| 1 | 306318 | Capacitor module, CAP PCB |
| 1 | 303694 | Fan Unit for TX and HV sub-rack |

Note

With regard to "PCB TX 36", it is recommended to include

- 3xPCB's for 0,5 and 1 degree systems
- 2xPCB's for 2 degree system

With regard to "Interface card TX RIO", it is recommended to include

- 2xPCB's for 1 degree system
- 1xPCB for 2 degree system

Table 21 Preamplifier Cabinet

| Pc | Our part nr. | Parts |
|----|--------------|-------------------------------|
| 1 | 290-213103 | Power Supply 12 Volt Complete |
| 1 | 308085 | PCB Dual Preamplifier EM 122 |

Table 22 Transducer Modules

| Pc | Our part nr. | Parts |
|---|--------------|---------------------------|
| 1 | EM1-213740 | TX module w/ 20m. cable |
| 1 | EM1-213764 | RX module w/ 20 m. cable. |
| On request: (not included in the spare part kit) | | |
| 1 | 302333 | RIO TXP |

Table 23 Hydrographic Workstation

| Pc | Our part nr. | Parts |
|----|--------------|-----------|
| 1 | 324098 | HWS |
| 1 | 301942 | Hard disk |

12 DRAWING FILE

This chapter holds the drawings referenced to in the other sections of the manual.

Note

The mechanical drawings are for information and guidance only. They are not in scale. All dimensions are in mm unless otherwise is noted.

Note that these drawings are not available in the electronic copy of this manual. The original installation drawings are available in PDF and/or AutoCad's DWG formats upon request.

Installation drawings

- *Rx Module* on page 124
- *Tx module* on page 125
- *Tx array mounting frame assembly 1 degree* on page 126
- *Tx array* on page 127
- *Rx array* on page 129
- *Rx array with casing – 2 degree* on page 130
- *Preamplifier* on page 132
- *Tx Junction Box* on page 133
- *Transducer cable layout* on page 134
- *HWS and display* on page 148

Cable details

- *Generic RS-232 Serial line* on page 136
- *Trigger in/out* on page 140
- *Control signals* on page 141
- *Control signals* on page 142
- *Ethernet cable with RJ45* on page 144
- *Ethernet cables 1x2 degree system* on page 146
- *Ethernet cables 0.5x1 and 1x1 degree system* on page 145
- *Tx transducer cables from junction boxes to TRU* on page 153
- *Tx transducer cables to transducer array* on page 155
- *Rx transducer cable from Preamplifier to TRU* on page 156
- *Preamplifier Unit cable from array* on page 157

Table 24 Operator Station

| Specifications | From/To |
|---|--|
| <i>Ethernet cable with RJ45</i> on page 144 | Operator Station → Transceiver Unit |
| <i>Ethernet cable with RJ45</i> on page 144 | Operator Station → Network (Ethernet) |
| <i>Generic RS-232 Serial line</i> on page 136 | Operator Station → Depth/Tide sensor |
| <i>Generic RS-232 Serial line</i> on page 136 | Operator Station → Sound Speed Sensor or probe |

Remark

- 1 The cables are commercial computer cables, and they are all supplied with the Operator Station

Table 25 Transceiver Unit

| Specifications | From/To |
|---|---|
| <i>Generic RS-232 Serial line</i> on page 136 | Transceiver Unit → Positioning system |
| <i>Generic RS-232 Serial line</i> on page 136 | Transceiver Unit → Motion sensor |
| <i>Generic RS-232 Serial line</i> on page 136 | Transceiver Unit → Auxiliary 1 |
| <i>Generic RS-232 Serial line</i> on page 136 | Transceiver Unit → Auxiliary 2 |
| <i>Control signals</i> on page 142 | Transceiver Unit → Remote control unit |
| <i>Ethernet cable with RJ45</i> on page 144 | Transceiver Unit → Operator Station |
| <i>Ethernet cable with RJ45</i> on page 144 | Transceiver Unit → Motion Sensor (velocity) |

Table 26 Preamplifier Unit

| Specifications | From/To |
|---|--------------------------------------|
| <i>Rx transducer cable from Preamplifier to TRU</i> on page 156 | Preamplifier Unit → Transceiver Unit |
| <i>Preamplifier Unit cable from array</i> on page 157 | Rx Transducer → Preamplifier Unit |

Table 27 Tx Junction Box 1

| Specifications | From/To |
|--|--------------------------------------|
| <i>Tx transducer cables from junction boxes to TRU</i> on page 153 | Transceiver Unit → Tx Junction Box 1 |
| <i>Tx transducer cables to transducer array</i> on page 155 | Tx Junction Box 1 → Transducer array |

Table 28 Tx Junction Box 2

| Specifications | From/To |
|--|---------------------------------------|
| <i>Tx transducer cables from junction boxes to TRU on page 153</i> | Transceiver Unit —> Tx Junction Box 2 |
| <i>Tx transducer cables to transducer array on page 155</i> | Tx Junction Box 2 —> Transducer array |

12.1 Rx Module

Figure 57 Rx Module, outline dimensions

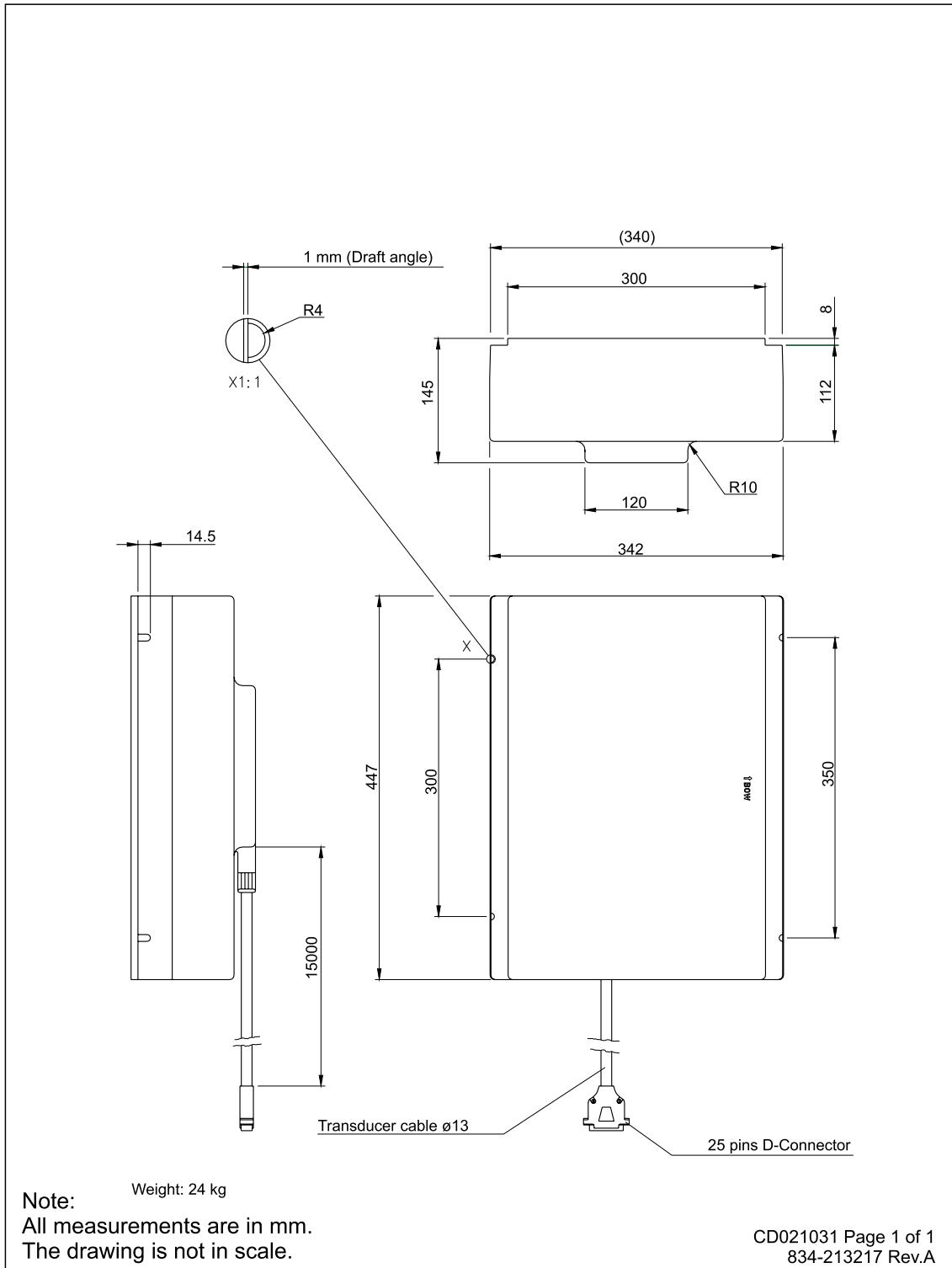

12.2 Tx module

Figure 58 Tx module – outline dimensions

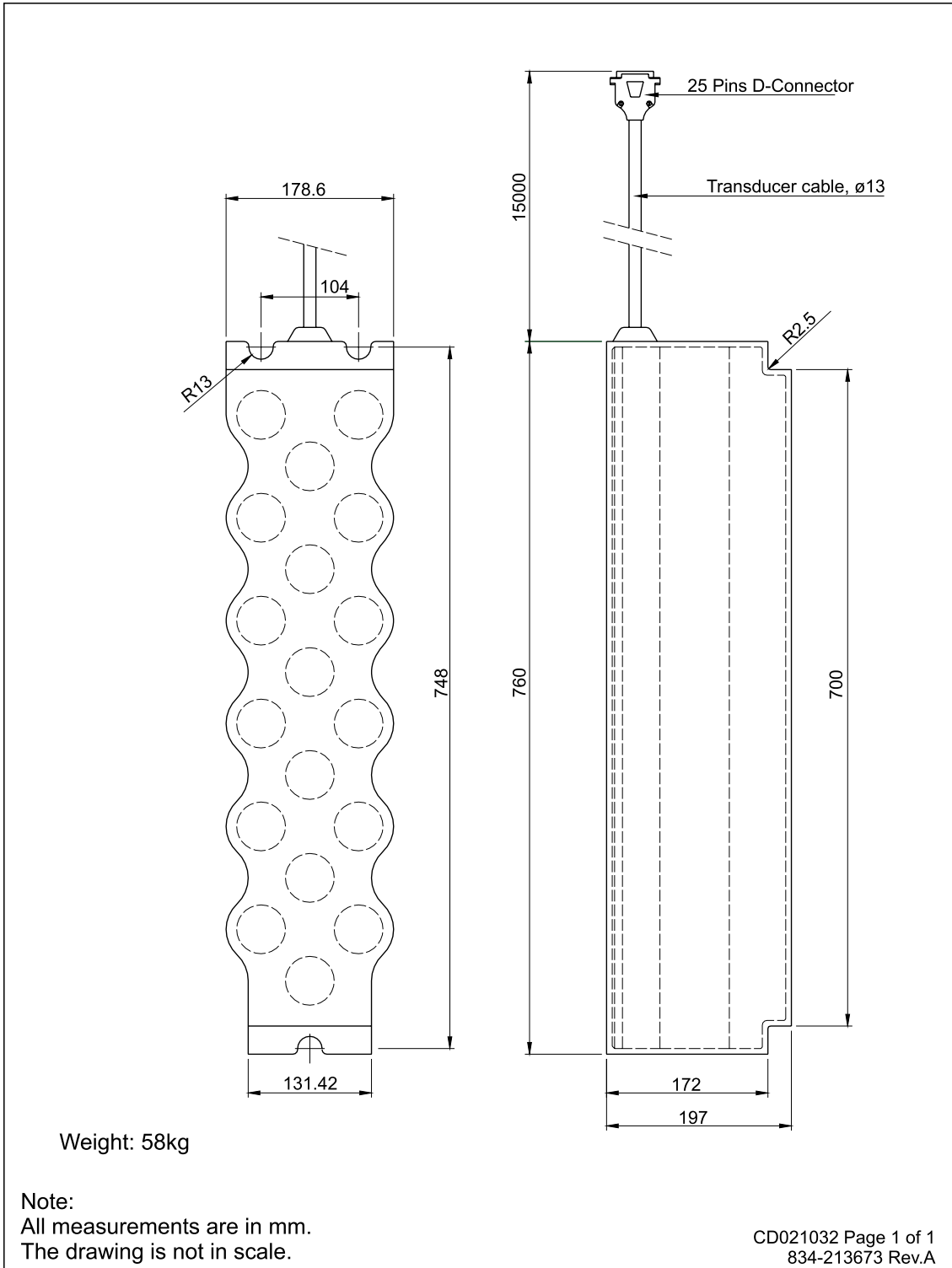

12.3 Tx array mounting frame assembly 1 degree

Figure 59 Tx array mounting frame assembly 1 degree

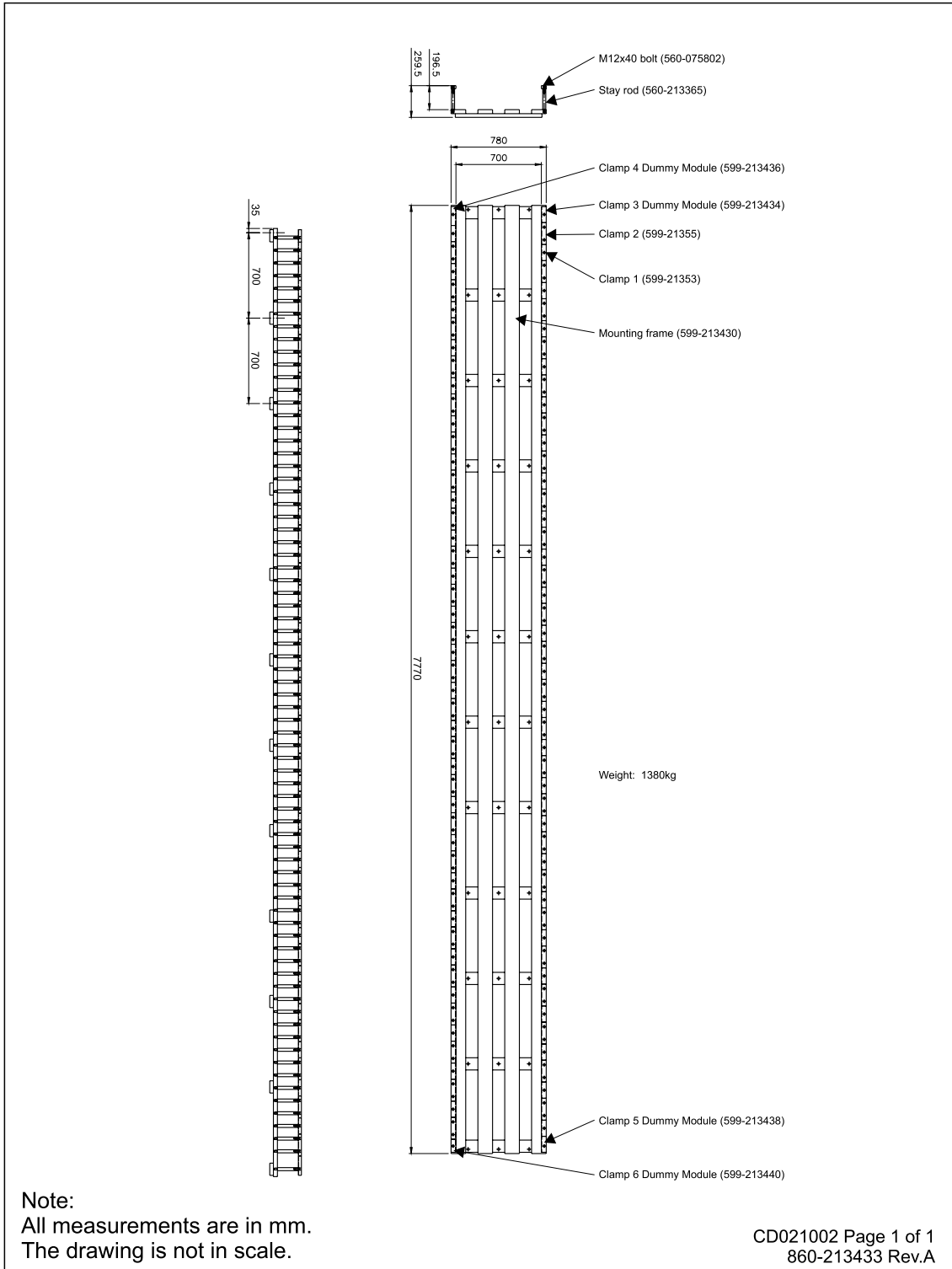

12.4 Tx array

Figure 60 Tx array with casing and modules – 1 degree

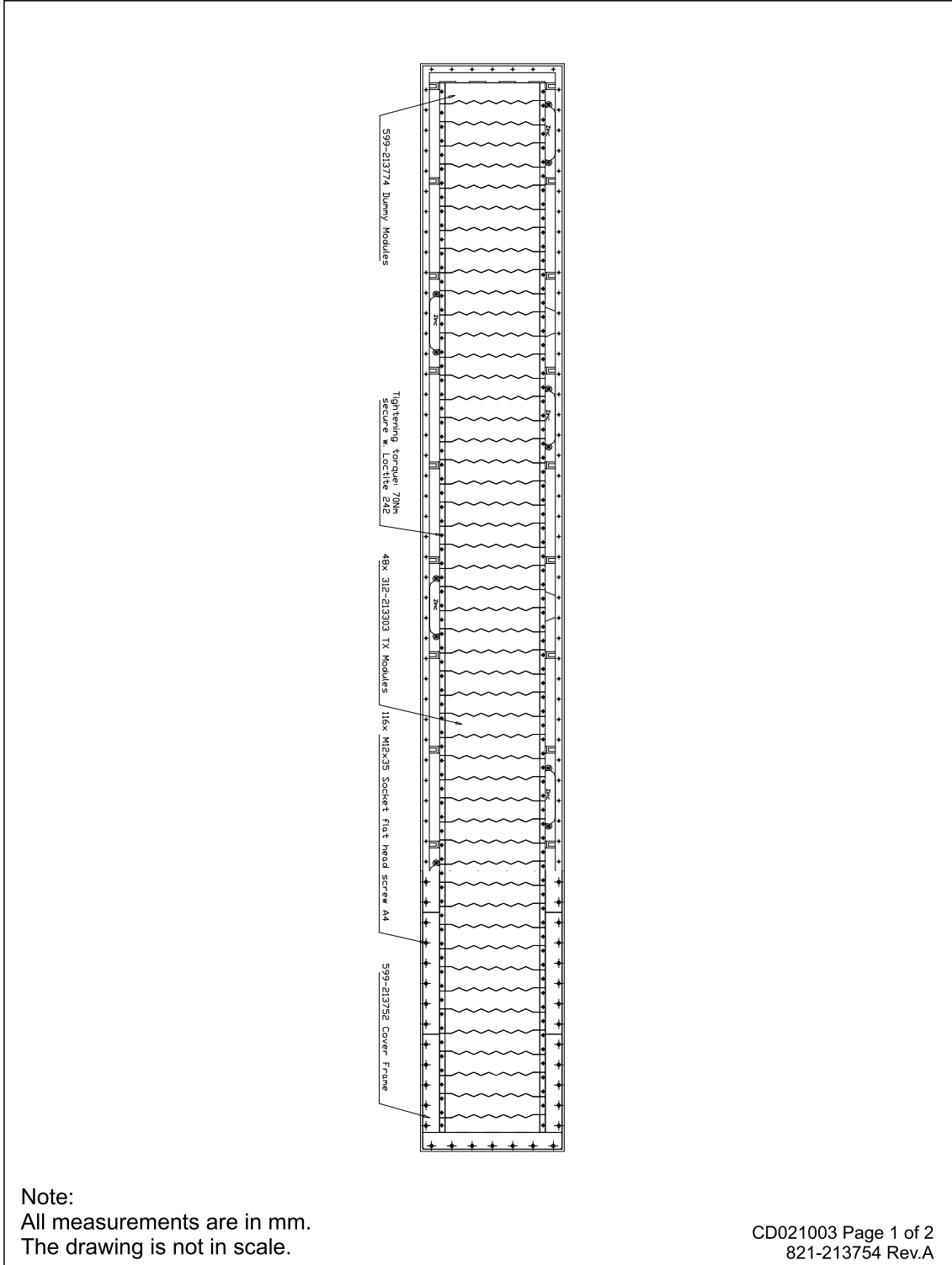
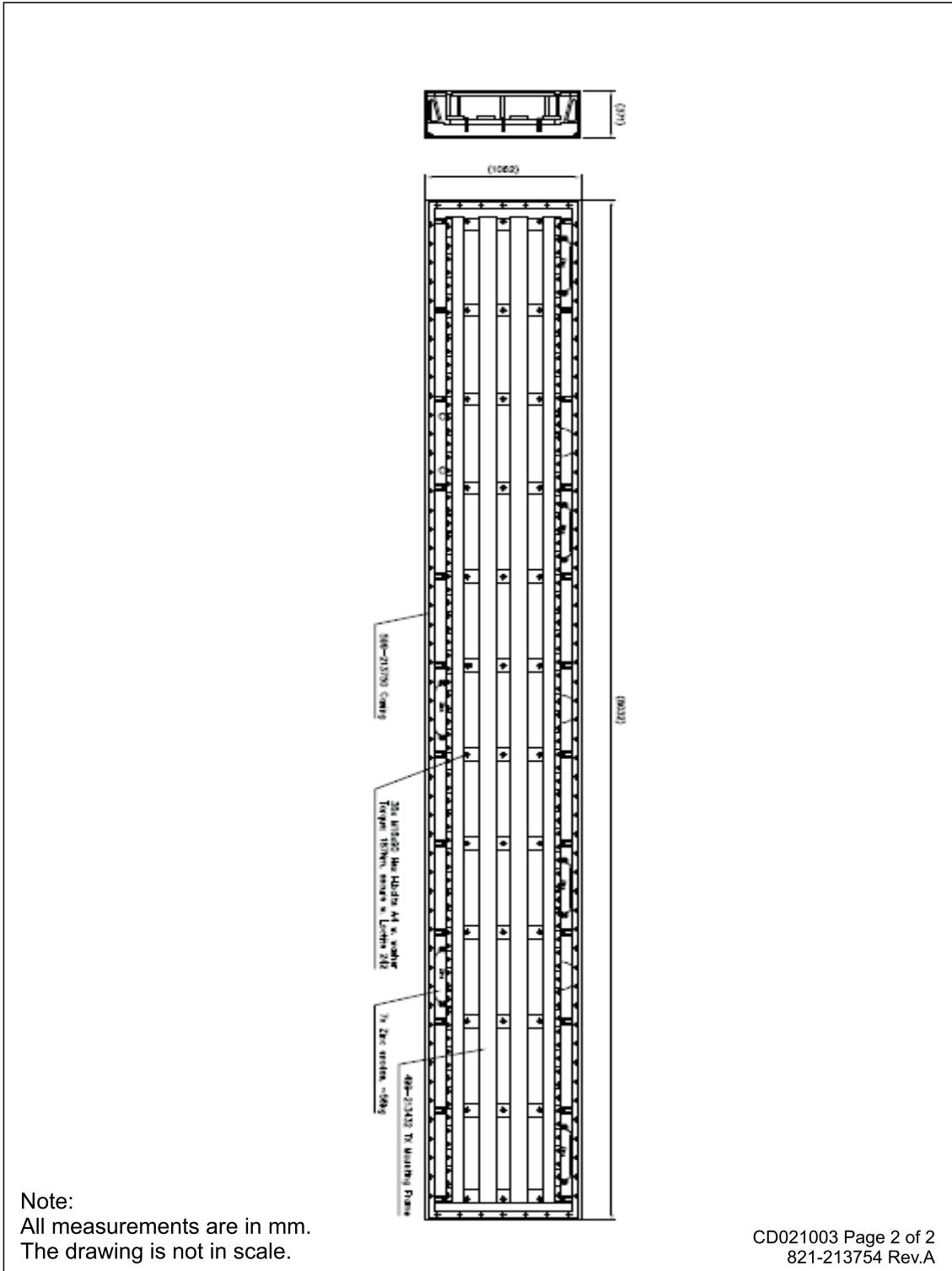

Figure 61 Tx array with casing and mounting frame – 1 degree



Note:
All measurements are in mm.
The drawing is not in scale.

CD021003 Page 2 of 2
821-213754 Rev.A

12.5 Rx array

Figure 62 Mounting frame assembly – Rx array 2 degree

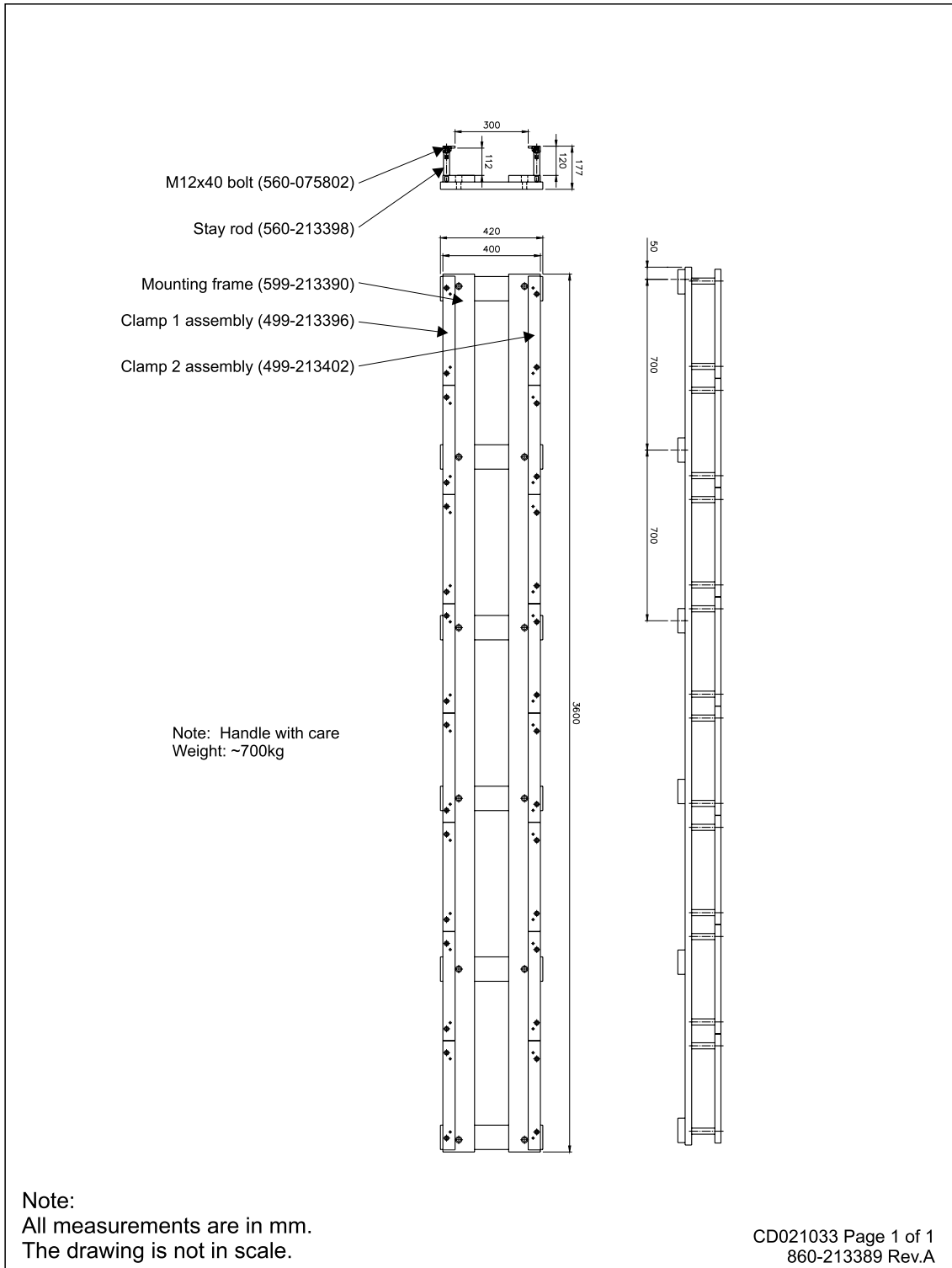

12.6 Rx array with casing – 2 degree

Figure 63 Rx array with casing and modules – 2 degree

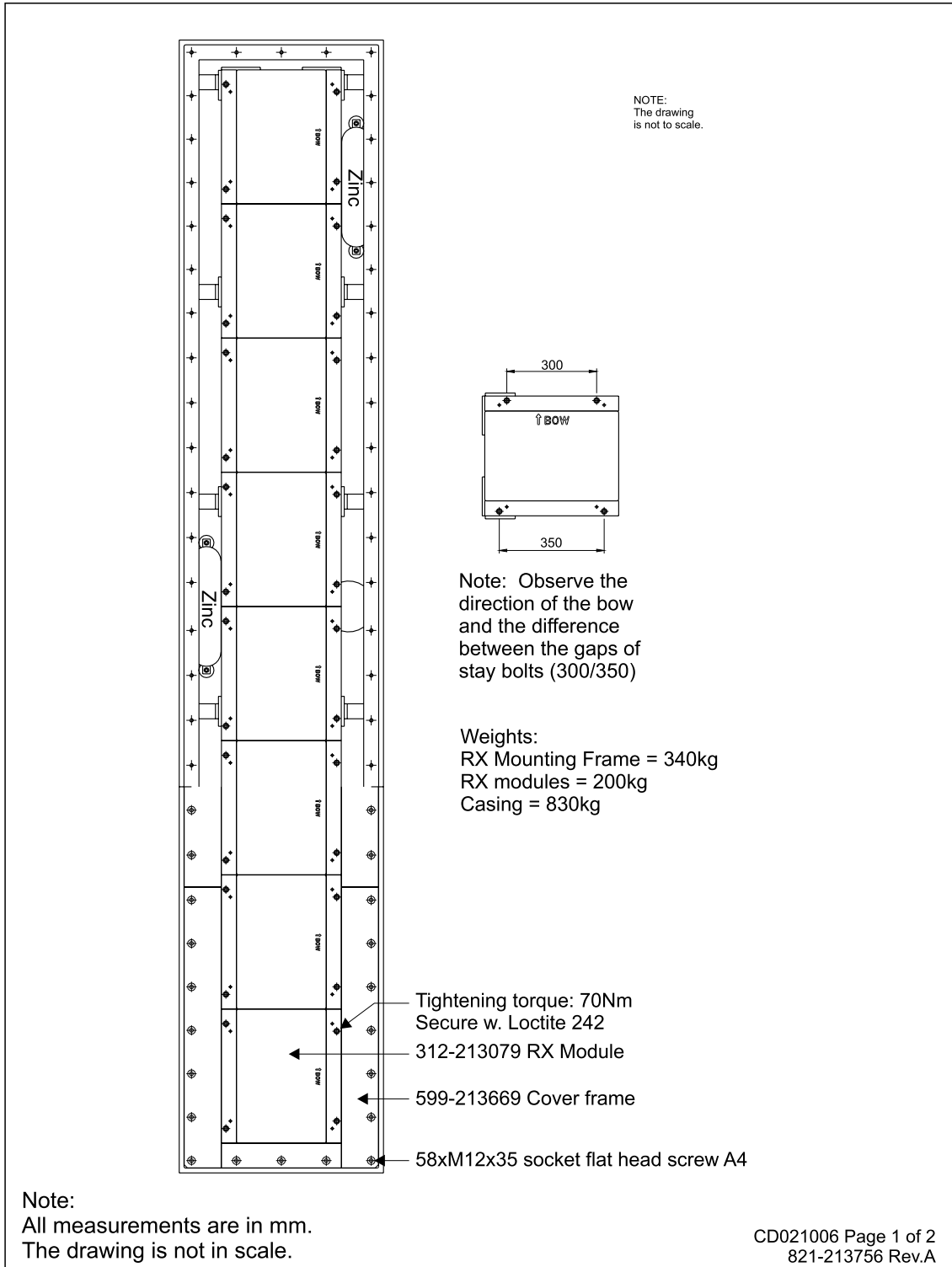
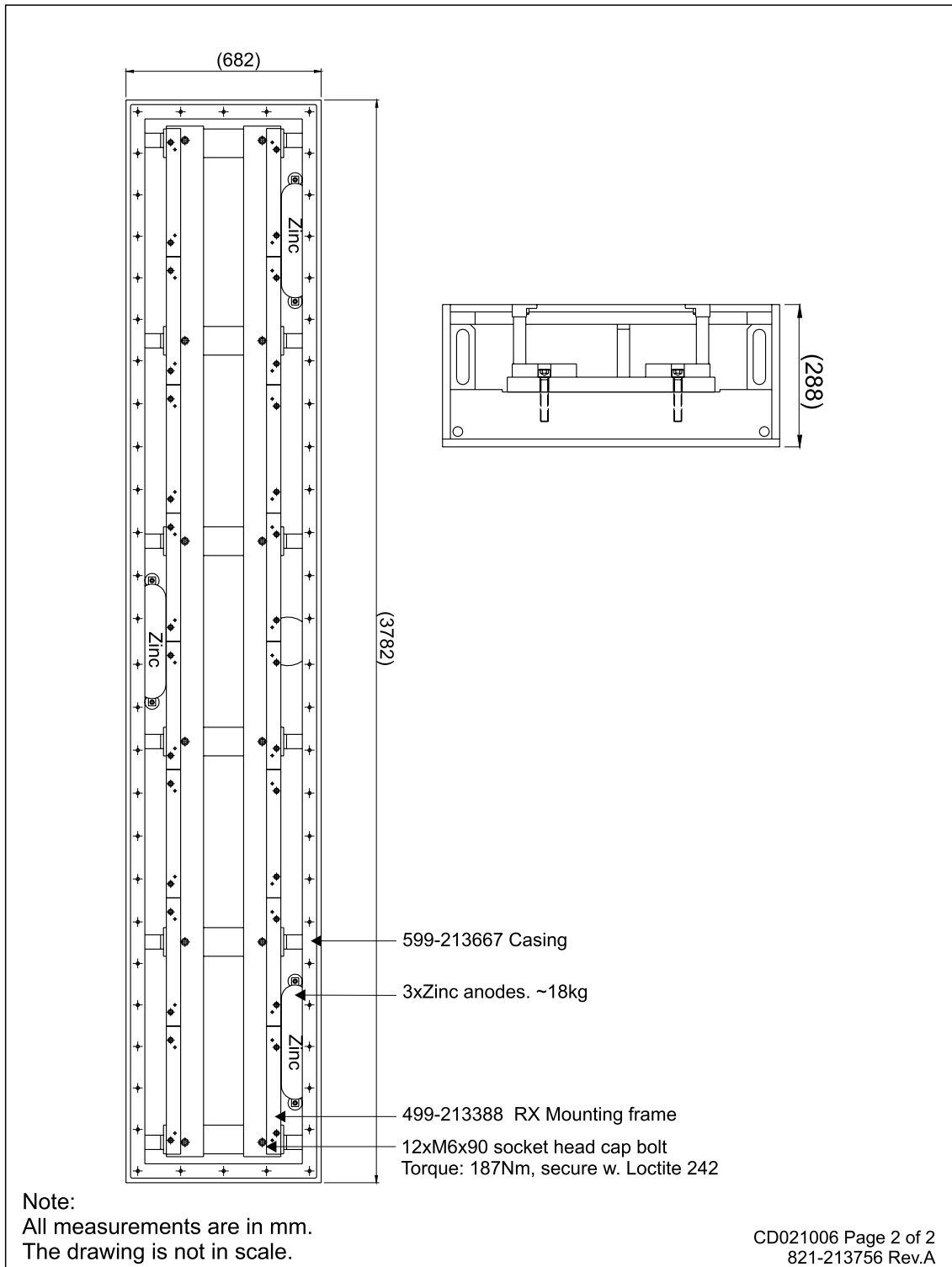
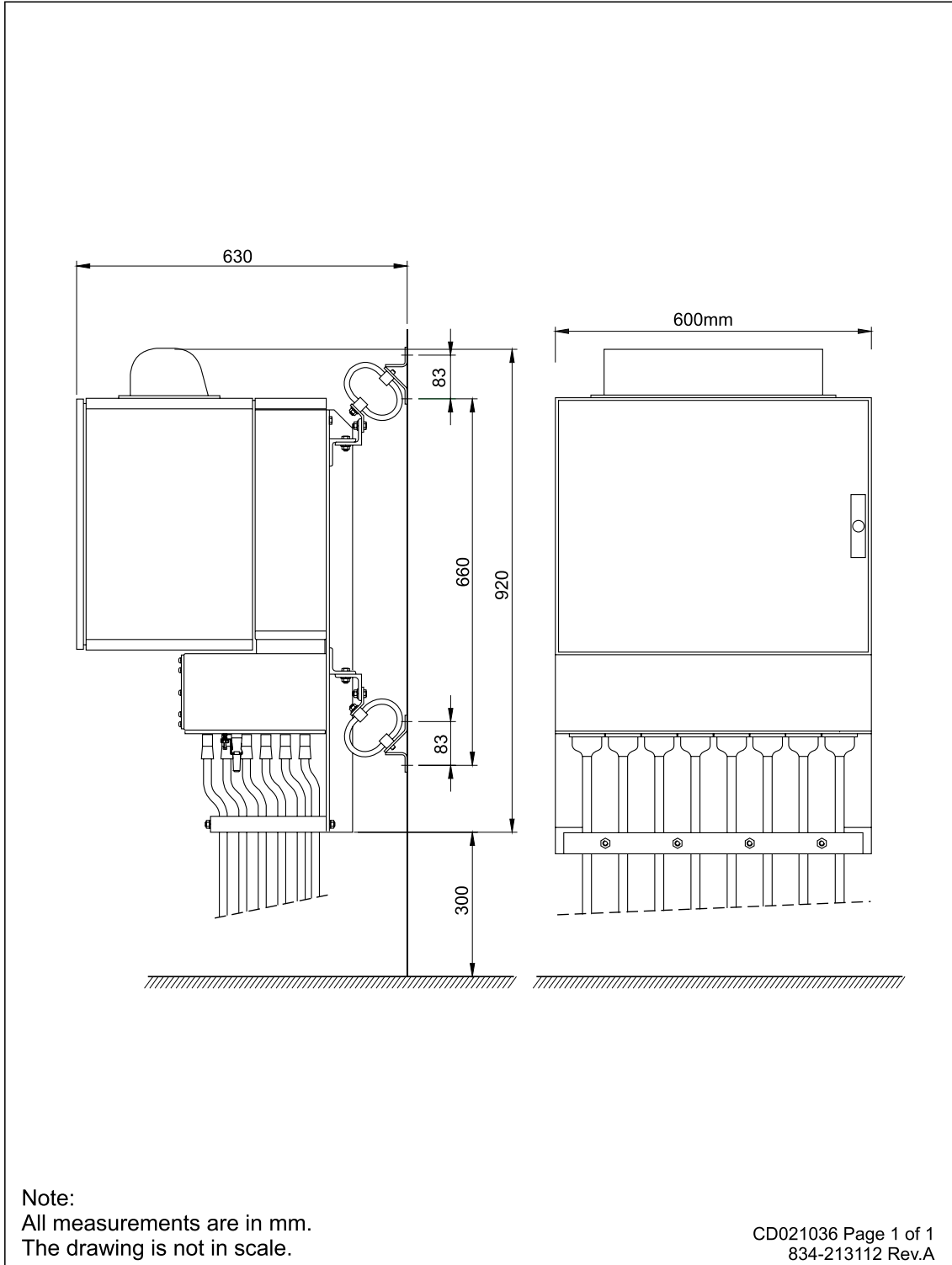

Figure 64 Rx array with casing and mounting frame – 2 degree



12.7 Preamplifier

Figure 65 Preamplifier outline dimensions



12.8 Tx Junction Box

Figure 66 Outline dimensions

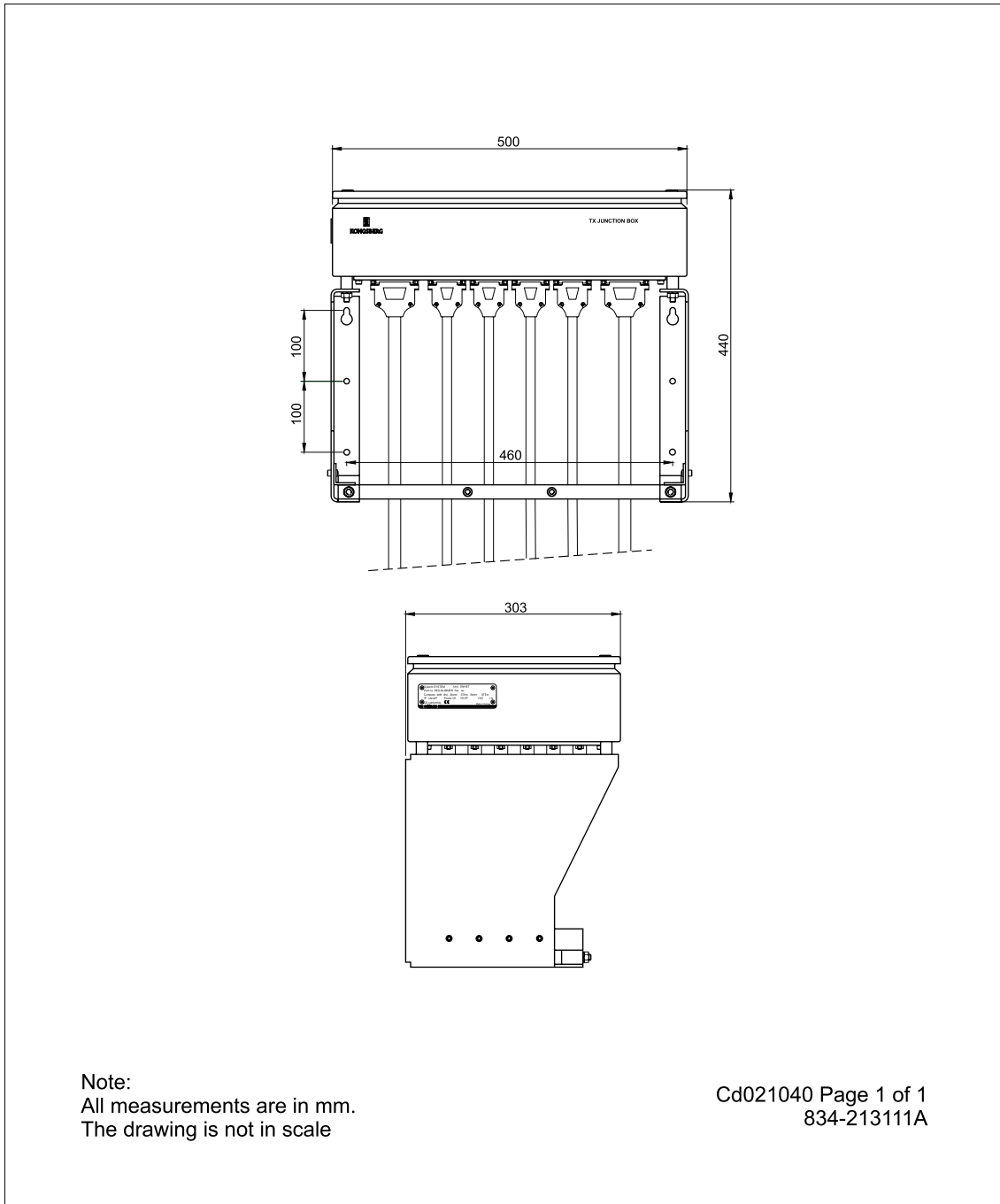

Note:
 All measurements are in mm.
 The drawing is not in scale

Cd021040 Page 1 of 1
 834-213111A

12.9 Transducer cable layout

Figure 67 Cable layout (page 1 of 2)

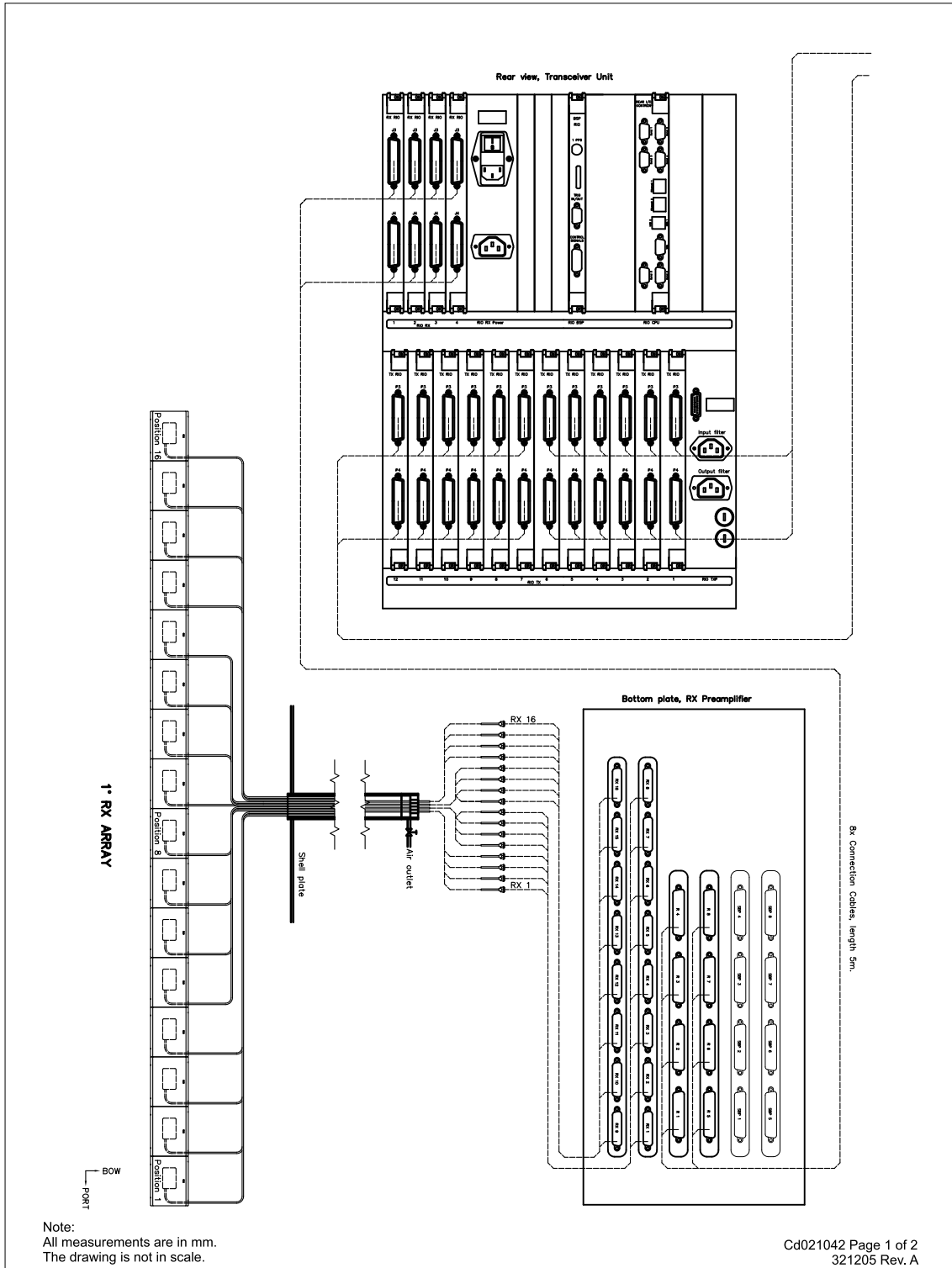
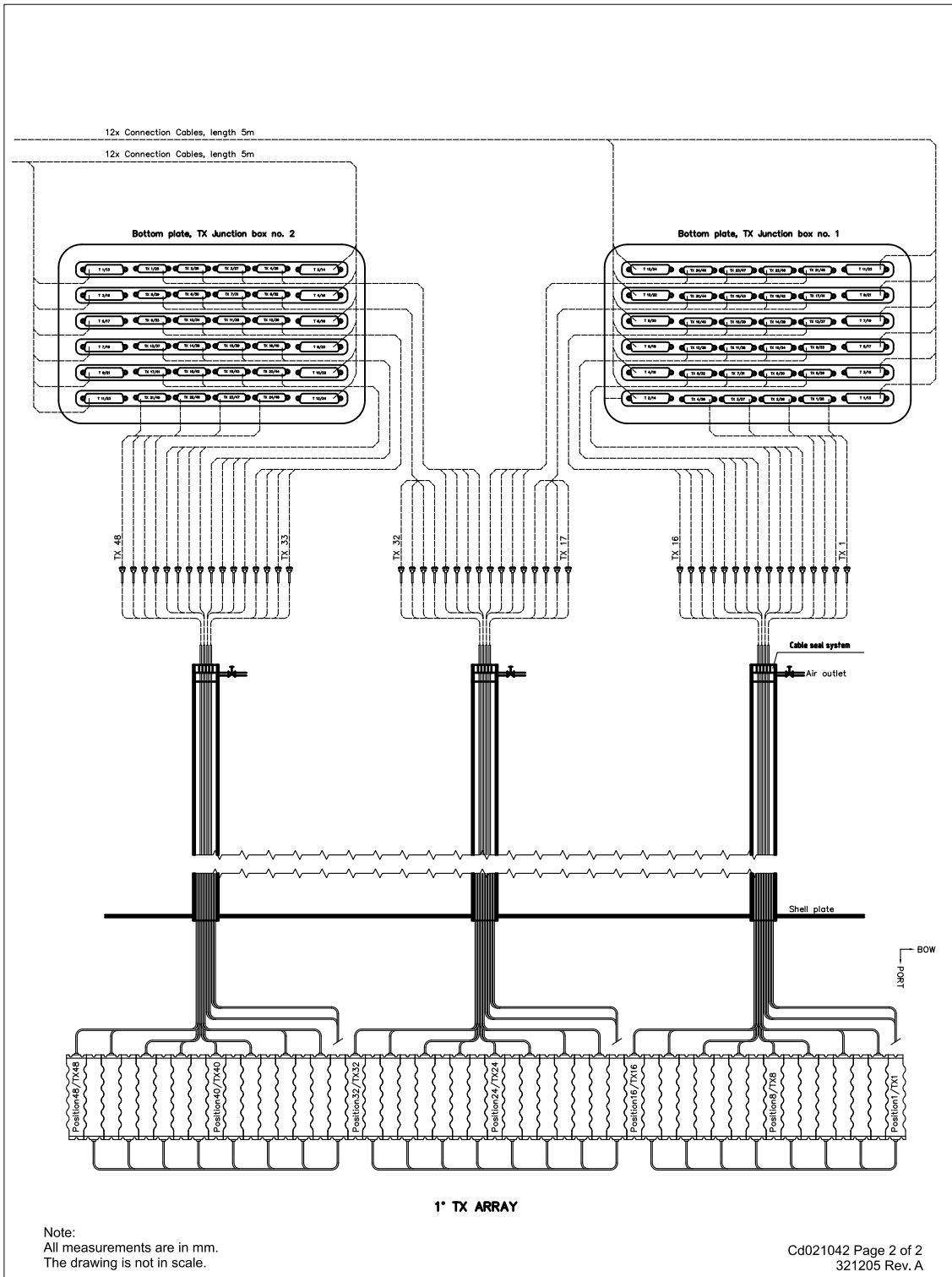
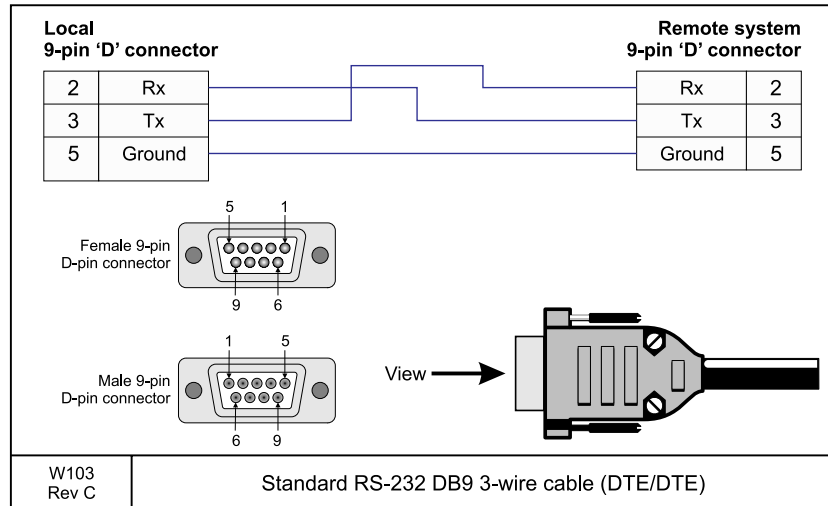

Figure 68 Cable layout (page 2 of 2)



12.10 Generic RS-232 Serial line

This cable holds a multi purpose serial line. It provides interface with any peripheral unit. One end of the cable connects to the local unit (DTE) with a 9-pin D-connector, while the other connects to the peripheral (DTE) as described in the peripheral unit's documentation. Note that this cable does not support all the signals in the standard RS-232 specification.



Cable specifications

- Conductors: 2 x 2 x 0.5 mm²
- Screen: Screened twisted pairs and overall braided
- Voltage: 60 V
- Maximum diameter: Limited by the plugs

12.11 Generic RS-232 Serial line

This cable comprises a multi purpose serial line. It provides interface with any peripheral unit. One end of the cable connects to the local unit (**DTE**) with a 9-pin D-connector, while the other connects to the peripheral (**DCE**) as described in the peripheral unit's documentation.

In many cases, only the **RxD**, **TxD** and **GND** pins are used. Twisted pairs are sufficient in the cable.

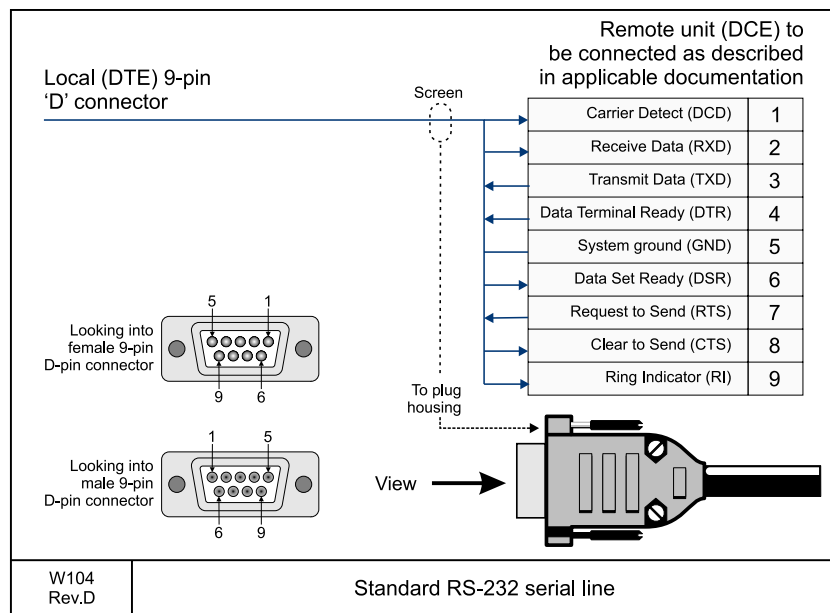

Cable specifications

- Conductors: 5 x 2 x 0.5 mm²
- Screen: Screened twisted pairs and overall braided
- Voltage: 60 V
- Maximum diameter: Limited by the plugs

12.12 Generic coax cable

This cable is used for connections to peripheral units or networks.

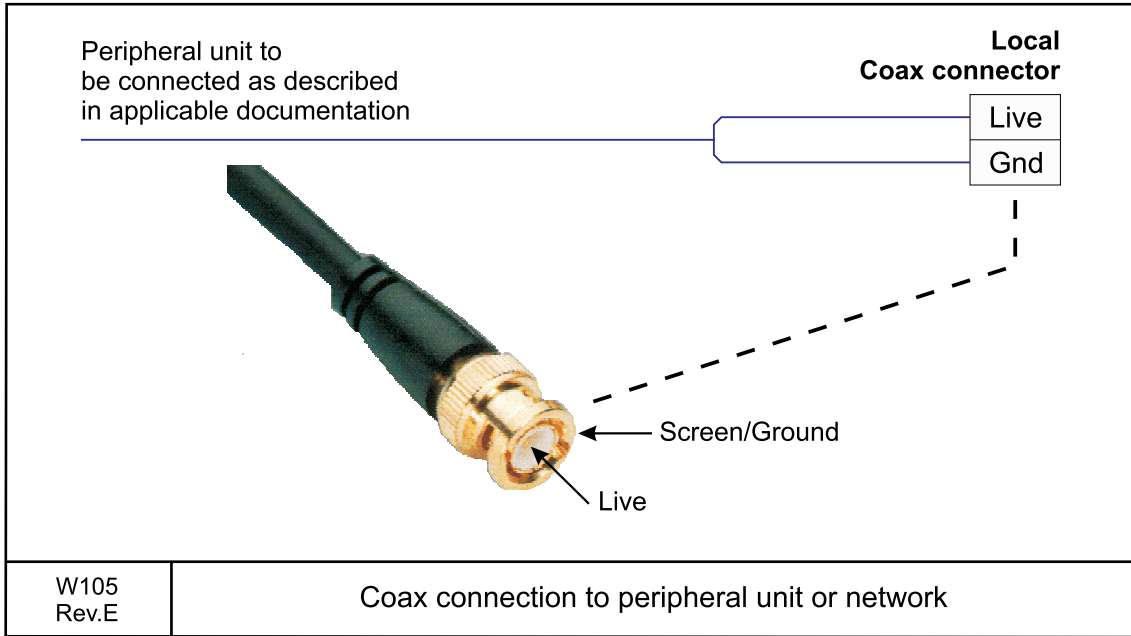

12.13 Sound speed probe interface

This cable provides the interconnection between the Processor Unit work station and the sound speed probe. This connection is normally made through a small junction box and with a power supply as indicated in the drawing.

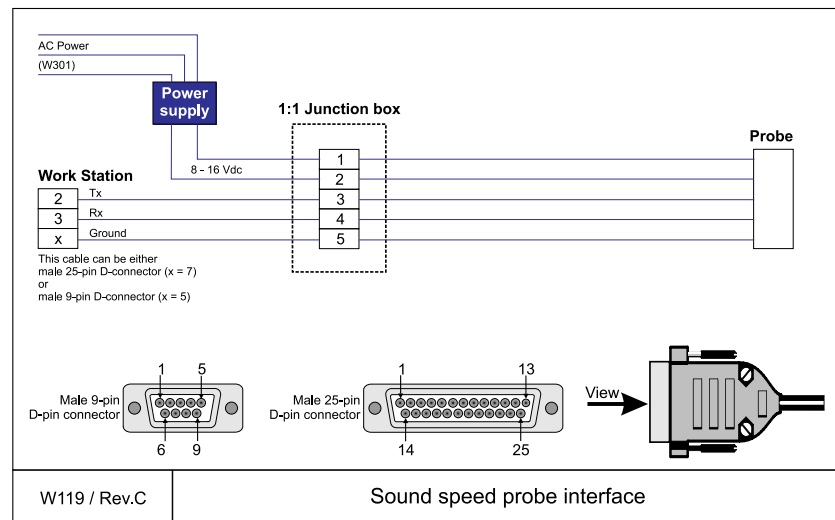

The cable between the junction box and the probe is supplied by the probe manufacturer.

- Conductors: 2 x 2 x 0.5 mm²
- Screen: Screened twisted pairs and overall braided
- Voltage: 60 V
- Maximum diameter: Limited by the plugs

12.14 Trigger in/out

This cable is used to synchronize the echo sounder's transmissions with other acoustic instruments. It is terminated in a standard 9-pin D-sub connector at the Transceiver Unit end.

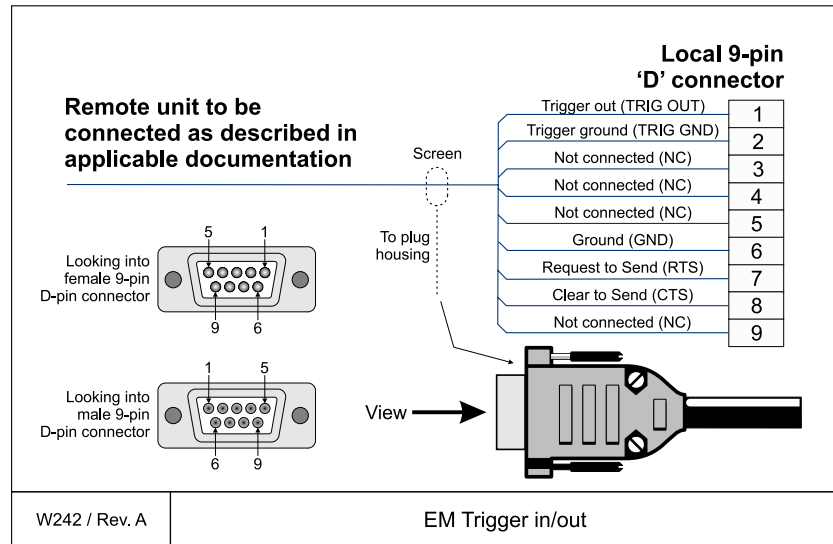

- Conductors: 5 x 2 x 0.5 mm²
- Screen: Screened twisted pairs and overall braided
- Voltage: 60 V
- Maximum diameter: Limited by the plugs

12.15 Control signals

This cable is used to transmit synchronization signals and TX enable signals. It is terminated in a standard 15-pin D-sub connector.

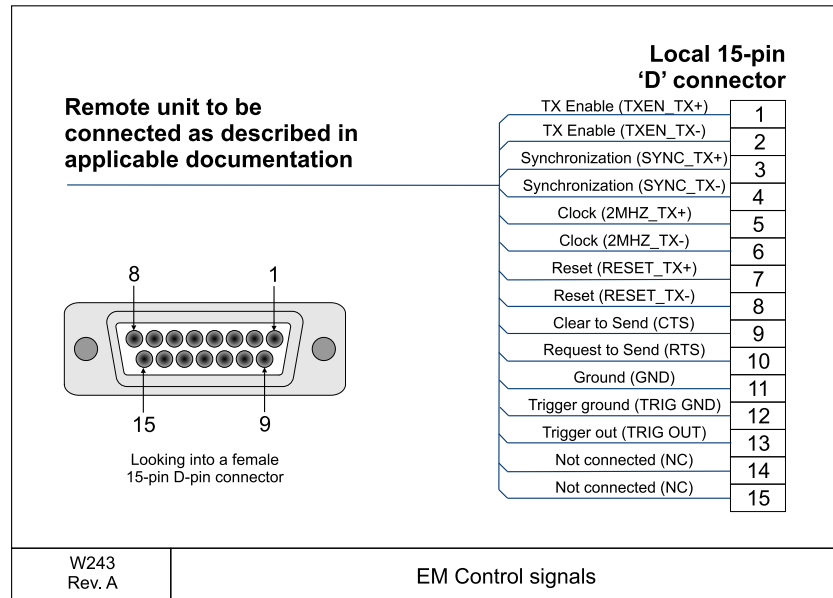

- Conductors: 9 x 2 x 0.5 mm²
- Screen: Screened twisted pairs and overall braided
- Voltage: 60 V
- Maximum diameter: Limited by the plugs

12.16 Control signals

This cable connects the EM 122 Transceiver Unit to a remote On/Off switch, normally located in a Remote Control junction box.

The same connection allows trigger output and remote control (synchronization) with a serial line.

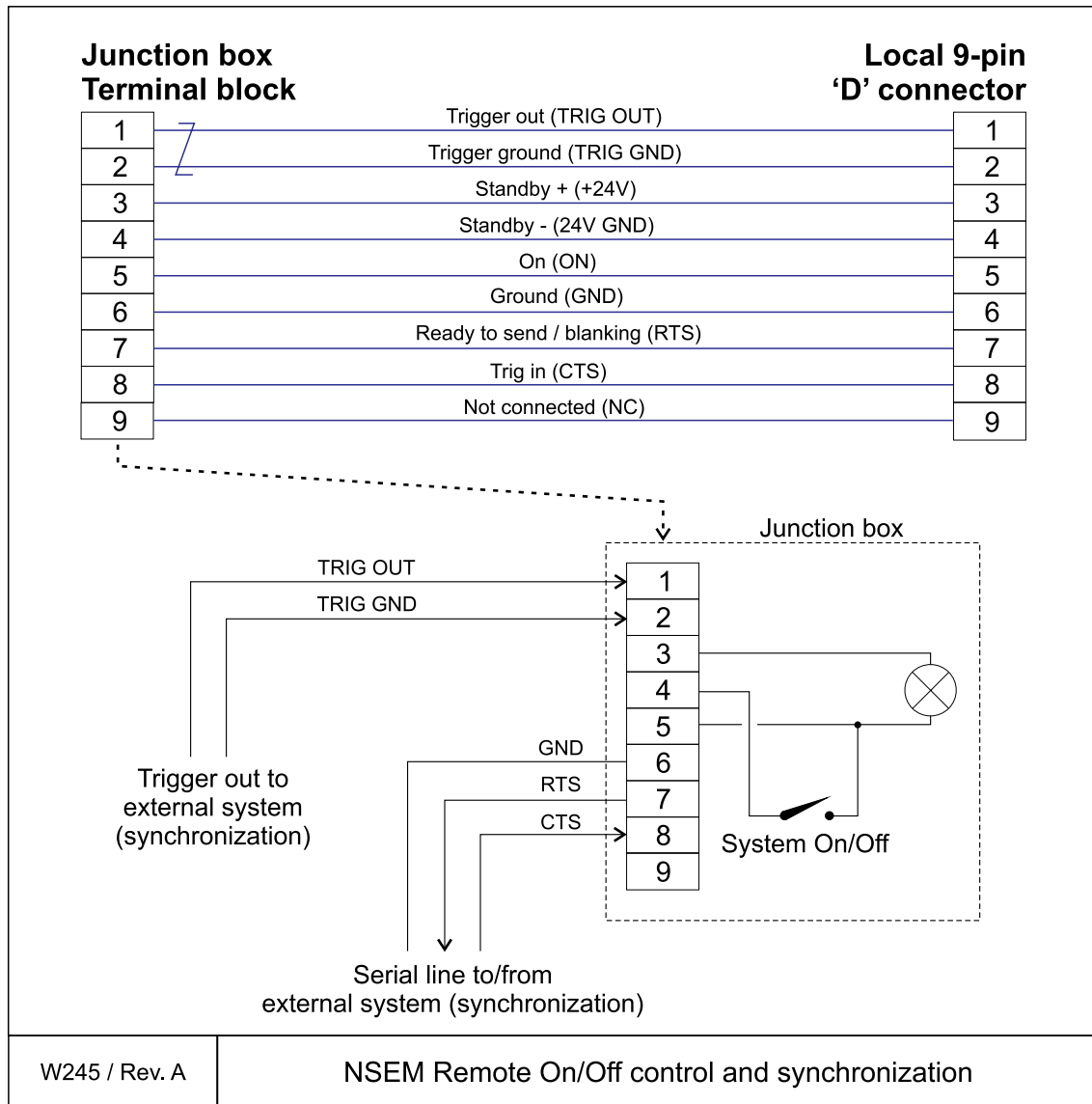

- Conductors: 5 x 2 x 0.5 mm²
- Screen: Overall braided
- Voltage: 60 V
- Maximum diameter: Limited by the plugs

12.17 Standard AC power cable

This cable is a standard three-wire power cable. The instrument end is terminated in a standard IEC female socket, while the other end is terminated in a plug suitable for the local standard.

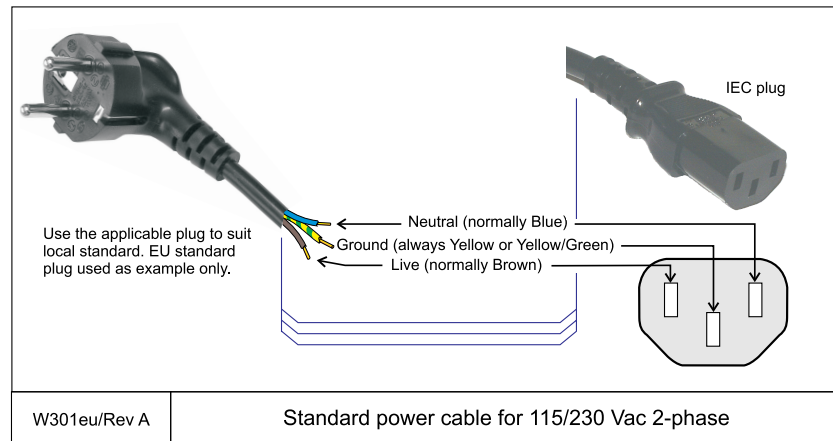

Note

*Different cable colours may be used for the **live** and **neutral** wires. Ground is however always on green/yellow.*

- Conductors: 3 x 1.5 mm²
- Screen: None
- Voltage: 750 V
- Maximum diameter: Defined by the manufacturer

12.18 Ethernet cable with RJ45

This cable is used to provide standard Ethernet connections. Note that various categories exist. **Cat.5 E** and **Cat.6** cables are used in local area networks with data rate exceeding 100 Mbit/s and Gigabit.

Ethernet cables are available commercially in different lengths, colours and categories.

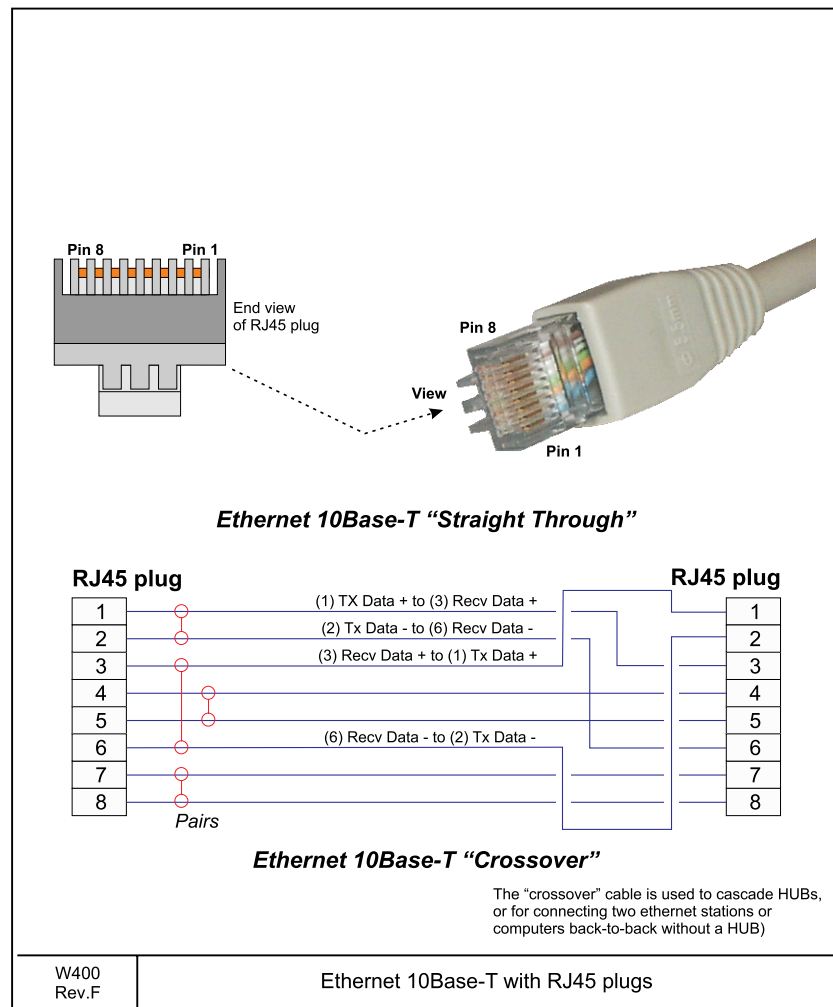

Screened category 6 (or 5 E) twisted pair cable to fit the specific RJ45 connectors used. AWG 23 and 24 size conductors are recommended.

12.19 Ethernet cables 0.5x1 and 1x1 degree system

Figure 69 Ethernet cables

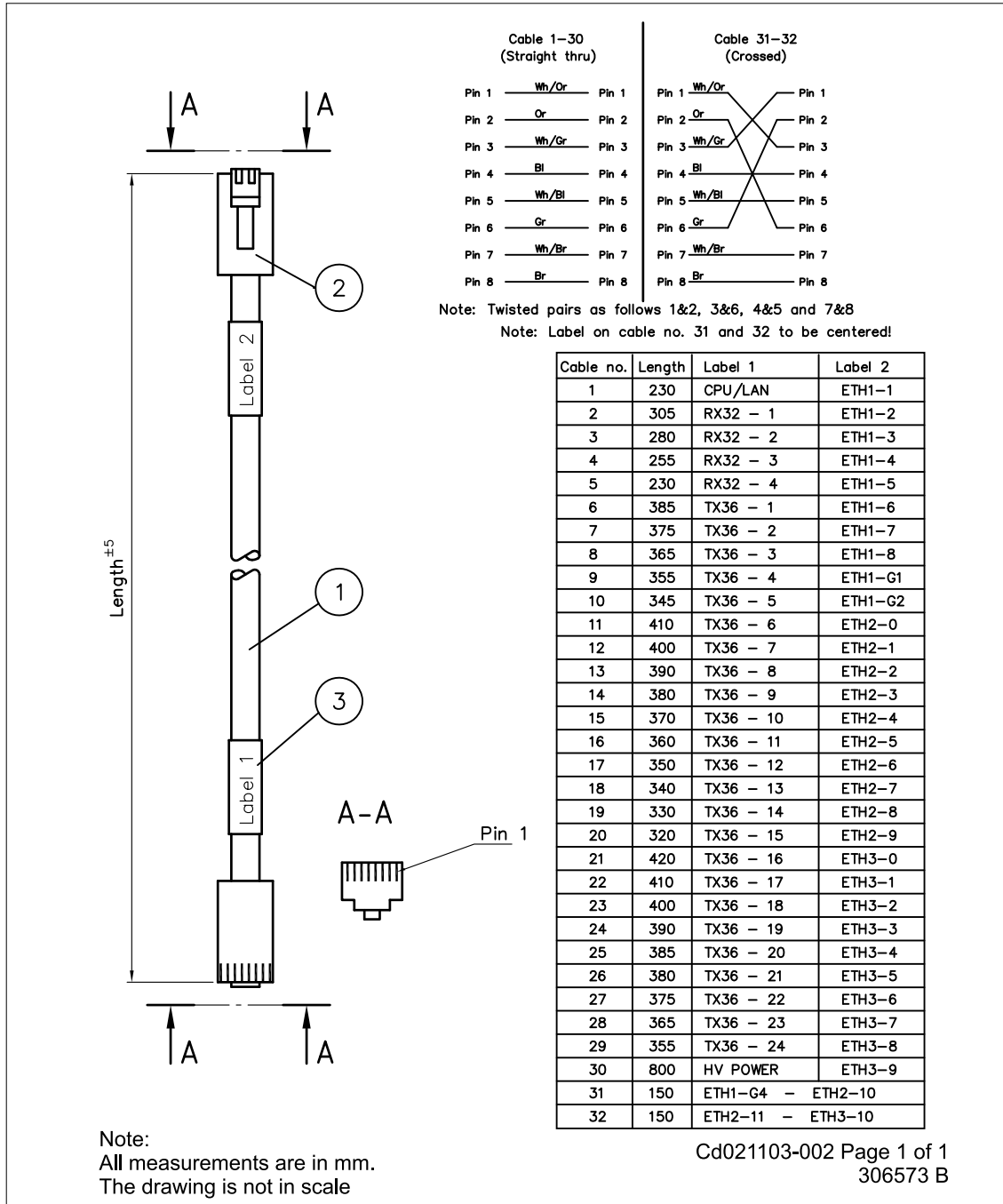

12.20 Ethernet cables 1x2 degree system

Figure 70 1x2 degree system

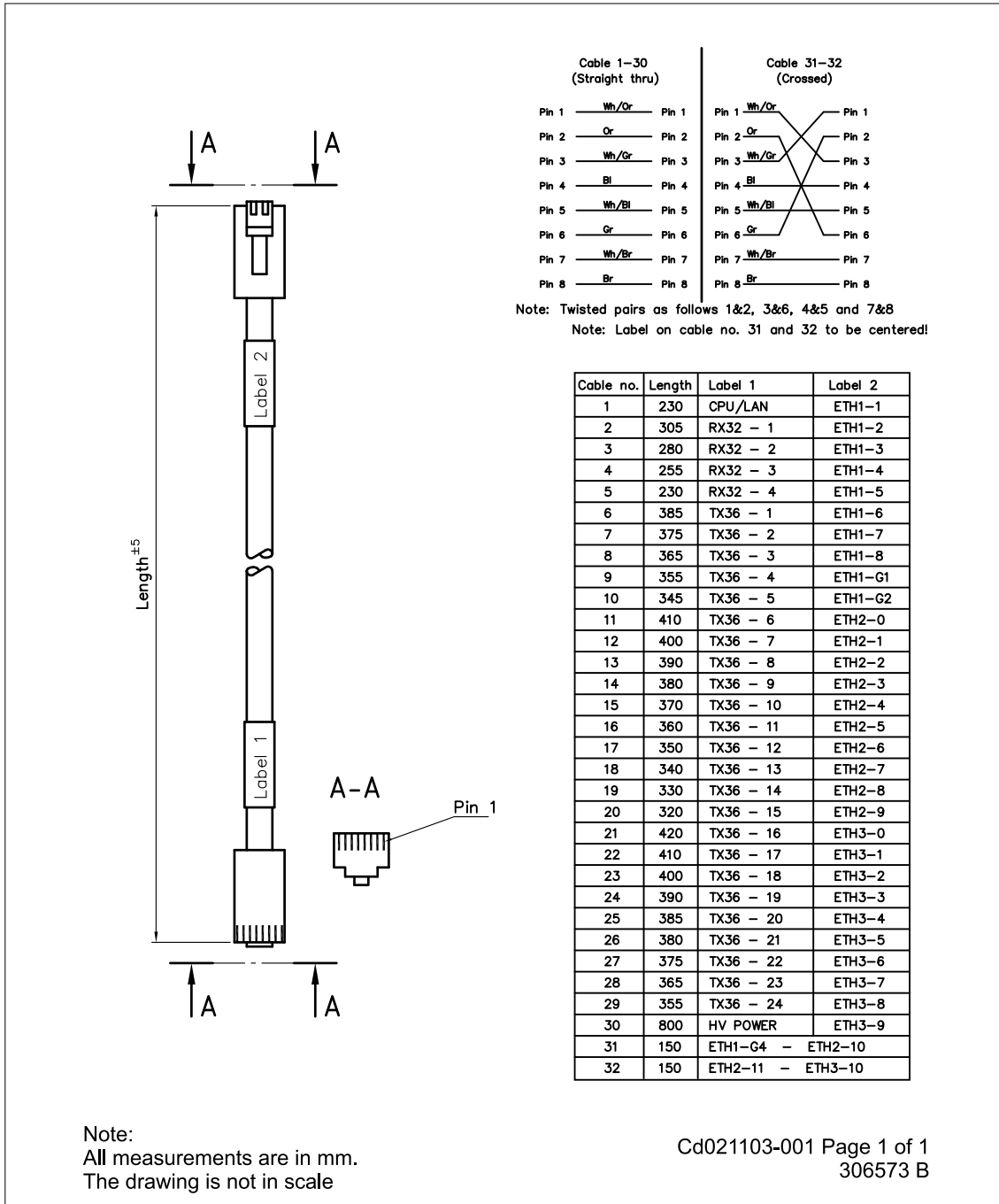

12.21 VGA/SVGA Display cable

This is a standard VGA/SVGA video cable. It is connected to the display.

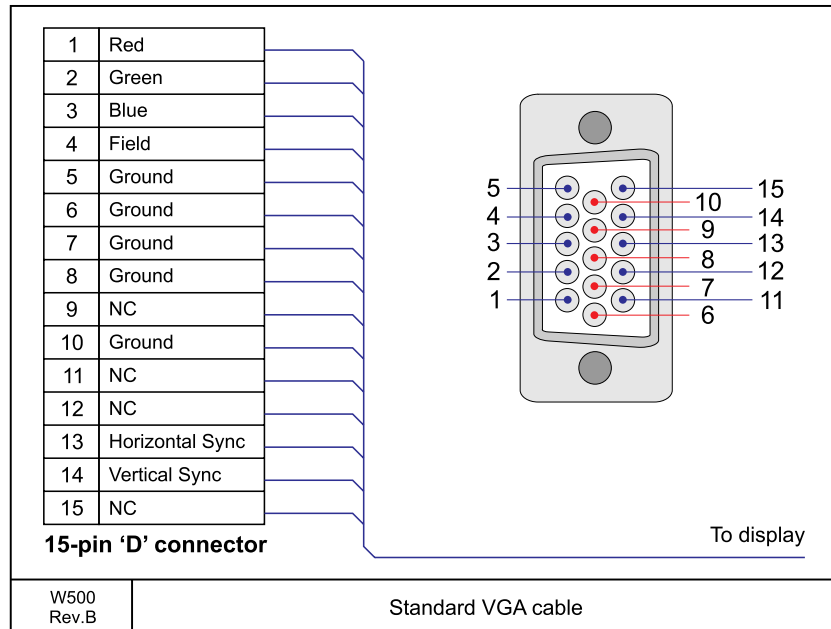

- Conductors: Defined by the manufacturer
- Screen: Defined by the manufacturer
- Voltage: Defined by the manufacturer
- Maximum diameter: Defined by the manufacturer
- Termination: 15-pin male D-connector

12.22 HWS and display

Figure 71 Outline dimensions

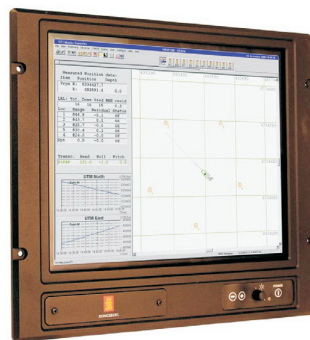

19" LCD:
Width = 483 mm
Height = 444 mm
Depth = 68 mm
Weight = 12 kg



HWS 19" Rack:
Width = 427 mm
Height = 180 mm/4U
Depth = 480 mm
Weight = 20 kg

Note:
All measurements are in mm.
The drawing is not in scale

Cd021046 Page 1 of 1
307181 Rev. A

12.23 USB cable

Just about any computer that you buy today comes with one or more Universal Serial Bus (USB) connectors on the back. These connectors let you attach everything from mouse to printers to your computer quickly and easily. Since the operating system supports USB, installation of device drivers is also easy.

In most cases, the USB cable is commercial, and they are normally supplied with the external devices. However, USB cables are also available commercially in different fixed lengths.

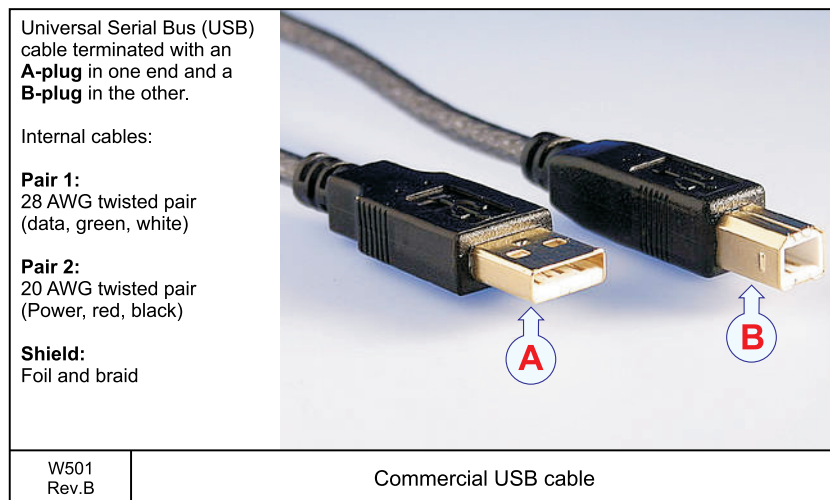

12.24 Keyboard cable

This is a standard keyboard cable. The cable is normally physically connected to the keyboard. It is terminated in a plug suited to fit the computer. Several keyboard types are available for different languages and hardware platforms. Both the keyboard and the attached cable are commercial items.

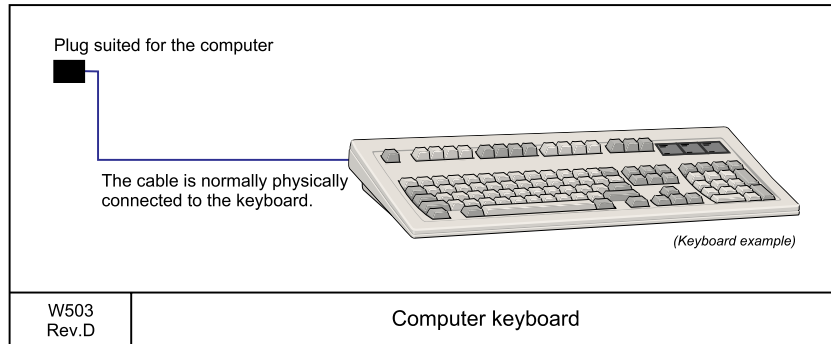

- Conductors: Defined by the manufacturer
- Screen: Defined by the manufacturer
- Voltage: Defined by the manufacturer
- Maximum diameter: Defined by the manufacturer
- Termination: USB, PS 2 or similar

12.25 Mouse cable

This is a standard mouse (or other pointing device) cable. It is physically connected to the mouse, and terminated in a plug suited to fit the computer. Several mouse and pointing device types are available with two or three buttons, and with or without a scroll wheel. Both the mouse and the attached cable are commercial items.

On Unix work stations, the mouse is normally connected to the keyboard.

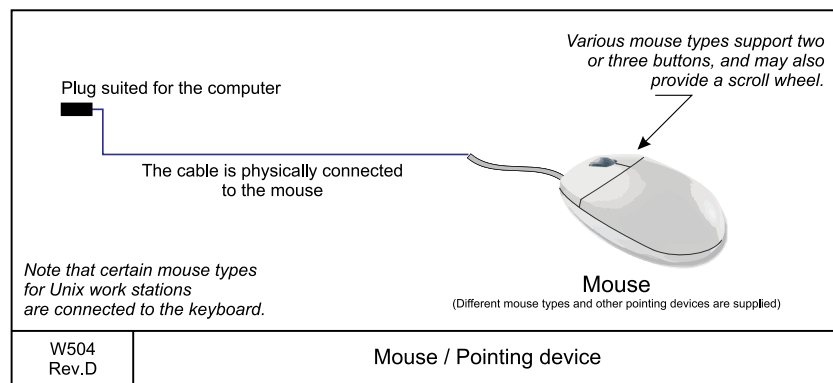

- Conductors: Defined by the manufacturer
- Screen: Defined by the manufacturer
- Voltage: Defined by the manufacturer
- Maximum diameter: Defined by the manufacturer
- Termination: USB, PS2 or similar

12.26 Parallel printer

This is a standard “Centronics” parallel printer cable. It is provided ready-made with printers, and also obtainable from commercial retailers.

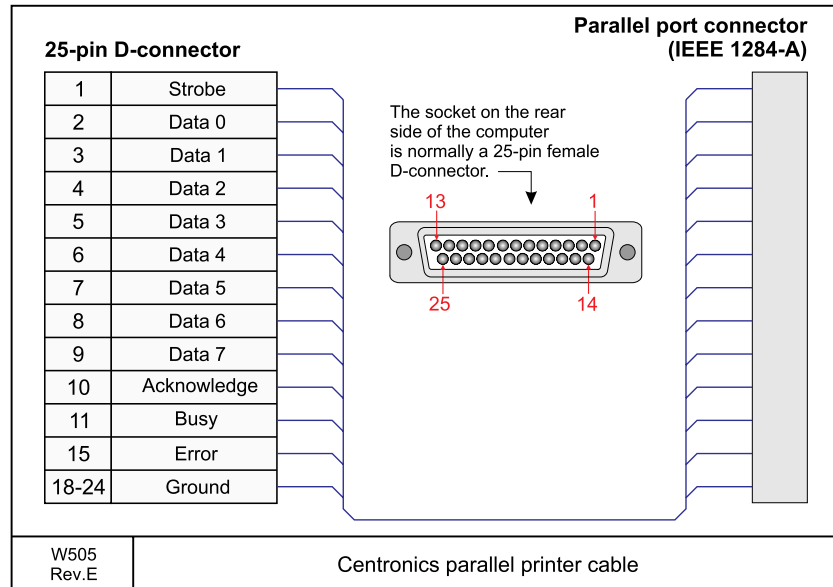

Cable specifications

- Conductors: Defined by the standard
- Screen: Defined by the cable manufacturer, normally overall braided
- Voltage: 60V
- Maximum diameter: Defined by the cable manufacturer
- Termination: 25-pin “D-sub” connector in one end, parallel port connector in the other end (IEEE 1284-A)

12.27 Tx transducer cables from junction boxes to TRU

These are one to one cables from the EM 122 Transceiver Unit to the Tx Junction Boxes. Each cable is terminated at the cabinet's rear through a 50-pin "D-sub" connector. The cables are supplied by manufacturer.

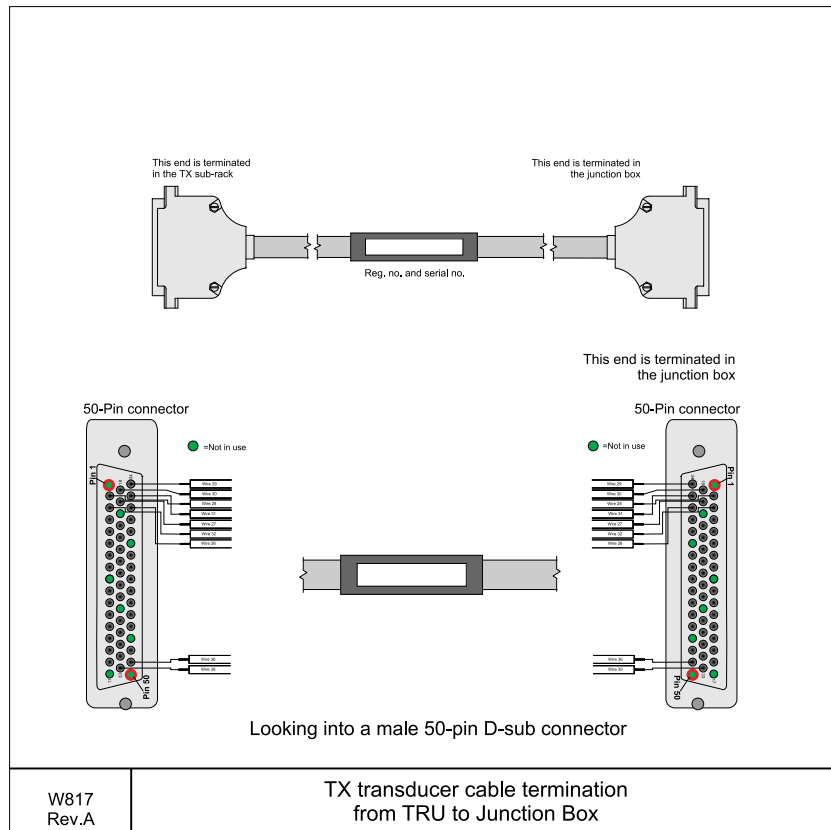

Table 29 50-pins "D-sub" connector

| Cable | 50-pin connector |
|----------|------------------|
| Wire no: | Pin no: |
| 29 | 34 |
| 30 | 18 |
| 26 | 2 |
| 31 | 35 |
| 27 | 19 |
| 32 | 3 |
| 26 | 36 |
| 14 | 4 |
| 33 | 37 |
| 13 | 21 |

Table 29 50-pins "D-sub" connector (cont'd.)

| Cable | 50-pin connector |
|-----------------|-------------------------|
| Wire no: | Pin no: |
| 34 | 5 |
| 12 | 38 |
| 35 | 22 |
| 11 | 6 |
| 9 | 23 |
| 23 | 7 |
| 10 | 40 |
| 22 | 24 |
| 15 | 8 |
| 8 | 41 |
| 1 | 25 |

Table 30 50-pins "D-sub" connector

| Cable | 50-pin connector |
|--------------|-------------------------|
| Wire | Pin no: |
| 2 | 42 |
| 3 | 26 |
| 7 | 10 |
| 4 | 43 |
| 6 | 27 |
| 16 | 11 |
| 5 | 44 |
| 25 | 12 |
| 17 | 45 |
| 24 | 29 |
| 18 | 13 |
| 21 | 46 |
| 19 | 30 |
| 20 | 14 |
| 42 | 31 |
| 36 | 15 |
| 41 | 48 |
| 37 | 32 |
| 40 | 16 |
| 38 | 49 |
| 39 | 33 |

12.28 Tx transducer cables to transducer array

These are the cables from the EM 122 Junction Boxes to the Tx transducer arrays. Each cable is terminated at the junction box through a 25-pin “D-sub” connector. At the transducer end, the cables is moulded to their respective modules. The cables are supplied by manufacturer.

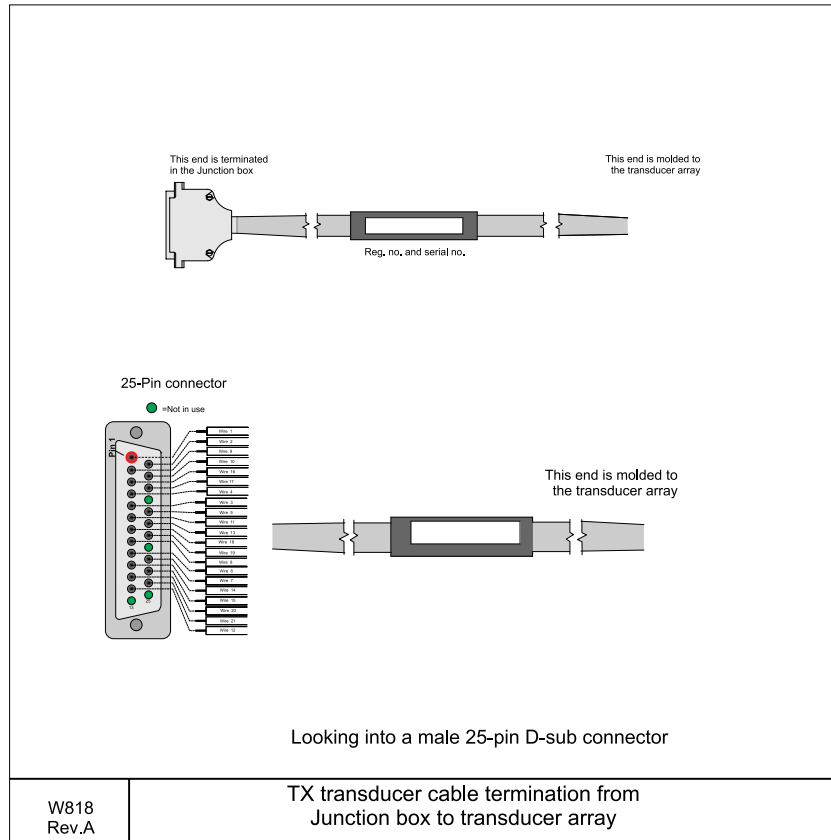
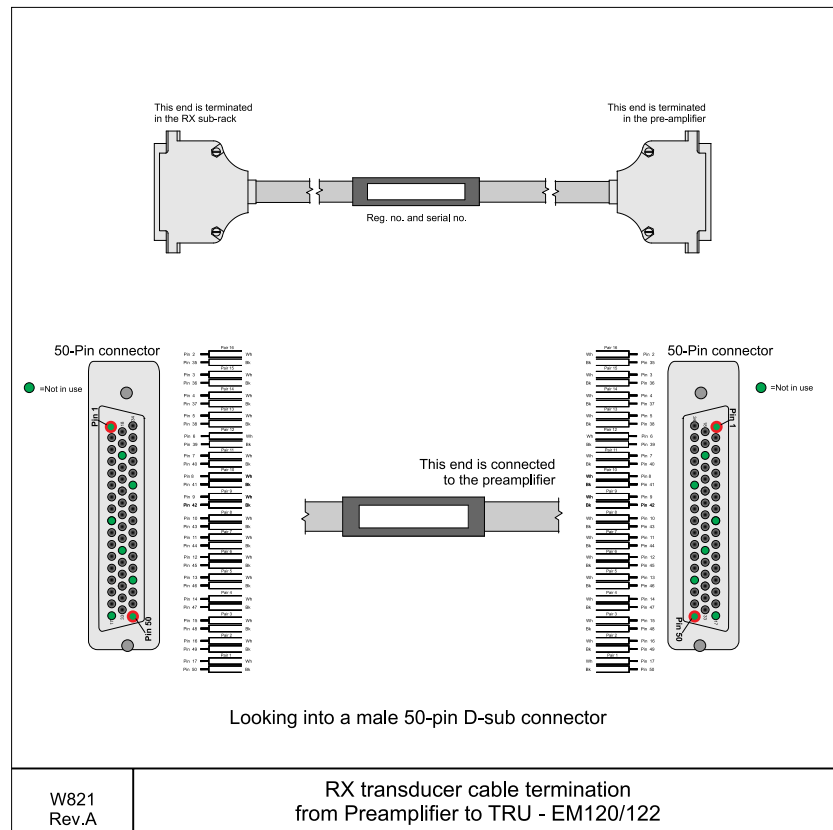

Table 31 25-pin “D-sub” connector

| Pin number | Wire number |
|----------------------|-----------------------|
| 6, 7, 8, 19, 20 | 8, 11, 13, 18, 19 |
| 5, 9, 18, 22 | 3, 5, 6, 7 |
| 3, 4, 10, 11, 16, 23 | 4, 14, 15, 16, 17, 20 |
| 1, 2, 12, 14, 15, 24 | 1, 2, 9, 10, 12, 21 |

12.29 Rx transducer cable from Preamplifier to TRU

This one to one cable is used from the EM 122 Preamplifier to the Transceiver Unit. Each cable is terminated at the cabinet's rear through a 50-pin "D-sub" connector. The cables are supplied by manufacturer.



Apply a label to the cable marked with module type (Rx) and the cable registration number (both ends).

Table 32 50-pin "D-sub" connector

| Pair No | Pin Number |
|--------------|------------------------------|
| 1, 2, 15, 16 | 2, 3, 16, 17, 35, 36, 49, 50 |
| 3, 14 | 4, 15, 37, 48 |
| 4, 5, 12, 13 | 5, 6, 13, 14, 38, 39, 46, 47 |
| 5, 7, 10, 11 | 7, 8, 11, 12, 40, 41, 44, 45 |
| 8, 9 | 9, 10, 42, 43 |

12.30 Preamplifier Unit cable from array

This cable is used from the array to the EM 122 Preamplifier Unit. The cable is terminated at the Preamplifier Unit bottom side through a 25-pin “D-sub” connector. The cables are supplied by manufacturer.

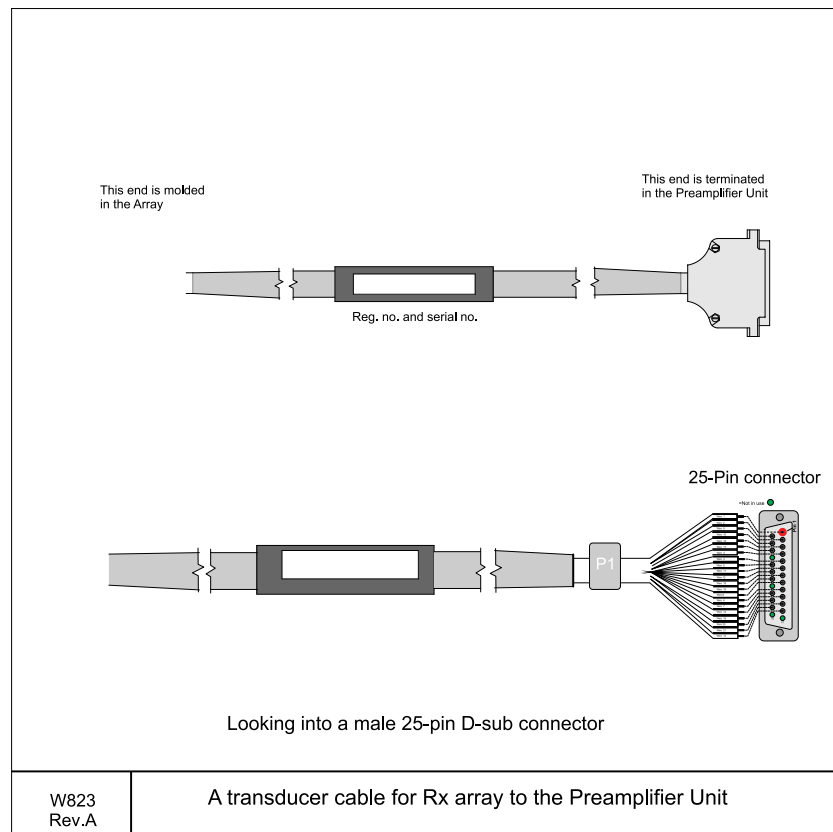

Apply a label to the cable marked with module type (Rx) and the cable registration number (both ends).

Table 33 25-pin “D-sub” connector

| Pin number | Wire number |
|----------------------|-----------------------|
| 6, 7, 8, 19, 20 | 8, 11, 13, 18, 19 |
| 5, 9, 18, 22 | 3, 5, 6, 7 |
| 3, 4, 10, 11, 16, 23 | 4, 14, 15, 16, 17, 20 |
| 1, 2, 12, 14, 15, 24 | 1, 2, 9, 10, 12, 21 |

©2009 Kongsberg Maritime

Kongsberg Maritime AS

Strandpromenaden 50
P.O.Box 111
N-3191 Horten,
Norway

Telephone: +47 33 02 38 00
Telefax: +47 33 04 47 53
www.kongsberg.com
subsea@kongsberg.com



KONGSBERG