

Scale=1:5

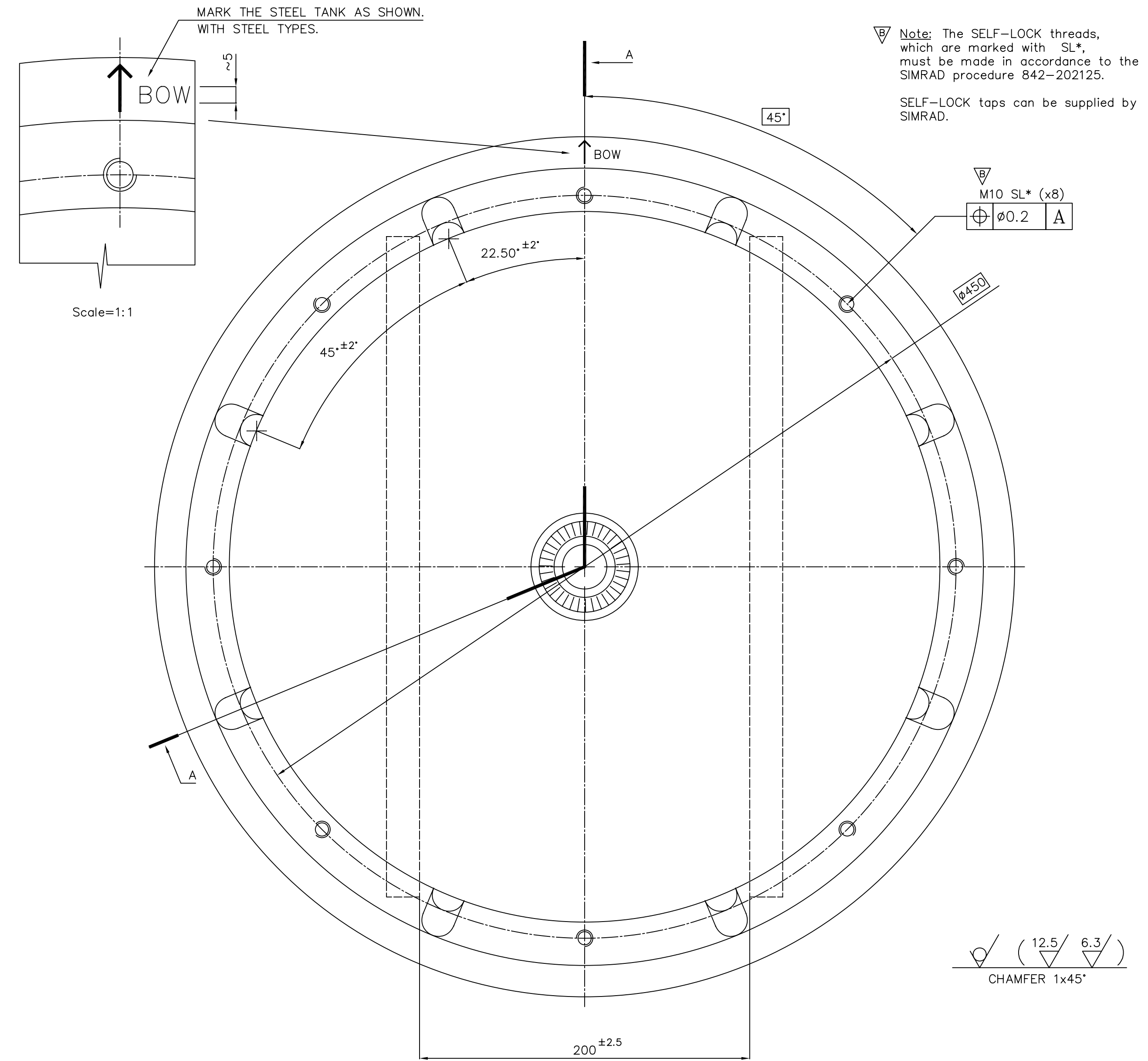

Note: The SELF-LOCK threads, which are marked with SL*, must be made in accordance to the SIMRAD procedure 842-202125.
SELF-LOCK taps can be supplied by SIMRAD.

- SURFACE TREATMENT:
1. SAND BLAST TO $S_a 2.5$
 2. 1 COAT RED IRON-OXIDE SHOP-PRIMER, 15 MICRON

TO BE STAMPED WITH DNV NUMBER.
TO BE DELIVERED WITH A DNV CERTIFICATE.
TO BE STAMPED WITH THE CHARGE NUMBER.
TO BE DELIVERED WITH A CHARGE CERTIFICATE 3.1C (DIN 5049/EN 10204)
TO BE DELIVERED WITH THE WELDER'S CERTIFICATE: NS-EN 287-1

THE INSTALLATION TO BE APPROVED BY THE LOCAL CLASSIFICATION SOCIETY.

WEIGHT STEEL TANK: ~172Kg

- *:NVA = EQUAL TO St 37-2/DIN 17100 = BS 4360/40B
- *:Fe 510C = EQUAL TO St 52-3 = BS 4360/50C
- *:NVE 36(DNV) = EH 36(LLOYDS)
- *:St 52-3N/ DIN 17100 = BS 4360/50D

ITEM	QTY.	DESCRIPTION	QUALITY	DIMENSION
4	2	STEEL BAR	NVA*	100x20 x400
3	1	STEEL BAR	Fe 510C*	$\phi 65 \times 115$
2	1	STEEL PLATE	NVE*	$\phi 500 \times 25$
1	1	STEEL TUBE	St 52-3N*	$\phi 521 \times \phi 421 \times 250$

REV./SIGN/B	KTP	DATE	PROJ. METHOD	SCALE	DRAWN	CHECKED	APPROVED	UNLESS OTHERWISE STATED, TOLERANCE: DIM.: ISO 2768-mK THREAD: 6g/6H	PARTS LIST:	FILE NO.:
		00.03.29		1:2	95.11.18	95.11.20	95.11.20		SIMRAD A HONGKONG Company	CAD01
STEEL TANK TRANSDUCER									SHEET 1 OF 1	SH.SIZE: A1
									599-133807	B
									ES 38-7	
									EA 500	