

MCON



KONGSBERG



INTEGRATED PROPULSION & THRUSTER CONTROL

MCON HIGHLIGHTS

- Optimised thruster performance
- Easy to operate and monitor
- Easy to add joystick and positioning products

Mcon Tunnel Thruster Control

Mcon Thruster Control System is a highly modular system that can be configured for mechanical and electric propulsion as well as all types of thrusters. The Thruster Control System can be operated as stand-alone electric tunnel thruster, to complement the AutoChief®600 Remote Control System, or can be completely integrated with the AutoChief®600 Remote Control System.

Mcon contains advanced control system software to minimize energy consumption as well as reducing mechanical wear. The development of this software has drawn upon the world class hydrodynamic expertise in Kongsberg.

The common touch-screen display enables user to monitor and operate the thruster unit.

Easy and Intuitive Operation

All essential operations can be conducted from the touch-screen display such as system activation and deactivation, command transfer, mode selection and silencing of audible alerts. Command transfer between multiple operator stations is consistently handled when delivered with our thruster control products and optional positioning products.

Through the common display, the operator gets easy overview of the system performance, alerts, signal trends, system settings and modes of operation. The graphical user interface is designed for touch-screen operation with intuitive interaction patterns.

Optional Functions

The Mcon product range is designed to facilitate easy upgrade to functions for joystick, positioning and transit sailing through the existing user display.

The system has an interface to ship-wide data logging, and is prepared for Remote Access for remote inspection and fault finding (will need separate hardware).



Bridge components: Display, indicator and input device

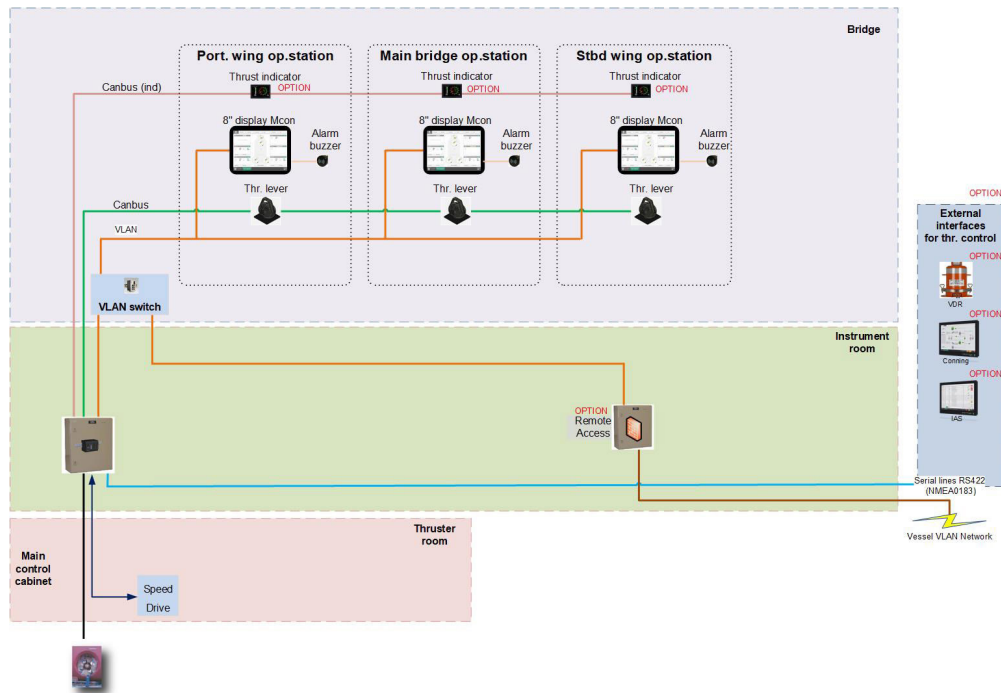

MAIN UNITS

FUNCTION

Control cabinet	Main electronic unit, one unit per propeller/thruster, comprising: <ul style="list-style-type: none"> Power supply Application CPUs I/O cards (DI, DO, AI, AO, serial line interfaces)
Network unit	Network routing, one unit per ship installation
Control Lever	Control levers (single or double), for console drop-in mounting
Indicators	Display instruments, customized for each installation. One per propeller/thruster. Desk or overhead drop-in mounting
Display Mcon	Panel PC with Graphical User Interface (touch screen) for readout of information, alarms and command inputs. Mounted with articulated arm on control desk top or operator's chair armrest top.

